

# *E series*

Robust design  
and overload capacity

Zero-backlash reduction gear

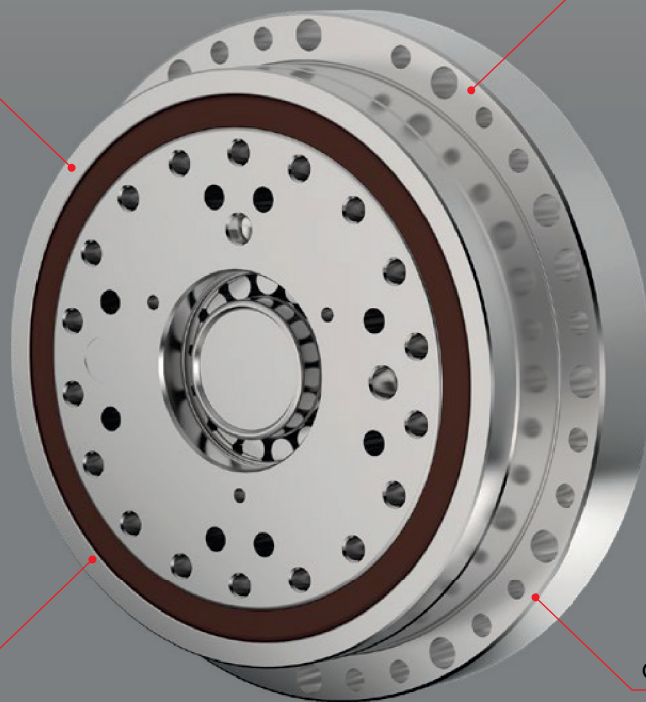

Integrated high  
capacity bearing

Customisable input shaft

EXCELLENCE IN PRECISION

## 2.4 E SERIES



### Advantages

- zero-backlash reduction gear
- high moment capacity
- excellent positioning accuracy and positioning repeatability
- high torsional and tilting stiffness
- small dimensions and weight
- high reduction ratios
- high efficiency
- long lifetime
- easy assembly

The **E series** represents a wide range of TwinSpin® high precision reduction gears with a flange shaped case. The E series high precision reduction gears comprise an accurate reduction mechanism and high-capacity radial and axial cylindrical bearings. This design of reduction gears allows the mounting of the load directly on the output flange or the case without the need of additional bearings. The E series high precision reduction gears are characterized by a modular design, which allows the mounting of your desirable type of motor to the reduction gear by means of a motor connection flange. The E series includes TwinSpin® high precision reduction gears that are not completely sealed; an inlet flange and a gasket kit have to be used for the sealing. Upon the customer's request, SPINEA is able to supply a completely sealed reduction gear with a flange according to the customer's motor.

Tab. 2.4a: E series features

<b>Case</b>	Threaded and through holes in the case
<b>Input flange connection</b>	The shaft sealing / adapter flange is offered in the following versions: a) motor connection flange b) sealed input cover c) without a flange
<b>Input shaft design</b>	The input shaft is offered in the following versions: a) shaft with a keyway b) according to a special request
<b>Installation and operation characteristics</b>	Special for robotic and general automation

Tab. 2.4b: E series ordering specifications

**TS - 200 - 125 - E - P24**

Name	Size	Ratio	Series version	Shaft version	
				P (DIN 6885)	S
<b>TS</b>	70	<b>41, 75</b>	E	11	•
	80	<b>37, 85</b>	E	8	•
	110	33, <b>67, 119</b>	E	14	•
	140	33, <b>69, 115</b>	E	19	•
	170	33, 59, <b>125, 141</b>	E	24	•
	200	49, 63, <b>125, 169</b>	E	24	•
	220	55, <b>125</b>	E	28	•

E series

Note: An example of an ordering code of a modified TwinSpin® T series reduction gear with a motor flange:  
 TS200 - 125 - TC - P24 - M235 - P231. The markings M235 and P231 for a specific modification are defined by the manufacturer.

## Shaft version

**P**

Shaft with a keyway

**S**

Special shaft

Tab. 2.4c: E series rating table

Size	Reduction ratio	Rated output torque	Max. acceleration / deceleration torque	Permissible output torque at emergency stop	Rated input speed	Max. allowable input speed 9)	Tilting stiffness 1) 5)	Torsional stiffness 1) 6)	Max. no-load starting torque 8)	Max. back-driving torque 8)
	i	T <sub>R</sub> [Nm]	T <sub>acc</sub> [Nm]	T <sub>em</sub> [Nm]	n <sub>R</sub> [rpm]	n <sub>max</sub> [rpm]	M <sub>t</sub> [Nm/arcmin]	k <sub>t</sub> [Nm/arcmin]	[Nm]	[Nm]
<b>TS 70</b>	<b>41</b>	50	100	250	2 000	4 000	40	8	0.30	11
	75					5 000			0.14	13
<b>TS 80</b>	<b>37</b>	78	156	390	2 000	4 000	70	10	0.35	14
	85					5 000			0.12	16
<b>TS 110</b>	33	122	244	610	2 000	3 500	115	24	0.35	24
	<b>67</b>					3 900			0.35	28
	119					4 500			0.20	33
<b>TS 140</b>	33	268	670	1 340	2 000	3 000	380	62	0.60	40
	<b>69</b>					4 500			0.40	50
	115								0.35	65
<b>TS 170</b>	33	495	1 237	2 475	2 000	3 000	1 100	110	2.00	75
	59					3 500			2.00	85
	<b>125</b>					3 900			1.20	125
	141					4 000			0.40	125
<b>TS 200</b>	49	890	2 225	4 450	2 000	2 500	1 300	200	2.10	80
	63					3 500			1.90	90
	<b>125</b>					4 000			1.70	200
	169					4 500			0.90	210
<b>TS 220</b>	55	1 250	3 125	6 250	2 000	2 400	1 900	310	1.80	75
	<b>125</b>					3 500			1.40	220

RIGHT TO CHANGE WITHOUT PRIOR NOTICE RESERVED

- 1) Mean statistical value. For further information see chapter Torsional stiffness, Tilting stiffness.
- 2) Load at output speed 15 rpm.
- 3) Moment  $M_{c,max}$  value for  $F_a=0$ . If  $F_a \neq 0$ , see chapter 3.5.
- 4) Axial force  $F_a$  max value for  $M_c=0$ . If  $M_c \neq 0$ , see chapter 3.5.
- 5) The parameter depends on the version of the high precision reduction gear.
- 6) The parameter depends on the version of the high precision reduction gear, ratio and lost motion.
- 7) The values of the parameters are informative. The exact value depends on the specific version of the high precision reduction gear.
- 8) Temperatures of the high precision reduction gear lower than 20°C will cause higher no-load starting or back driving torque.
- 9) Instantaneous speed peak that may occur within the working cycle.

Tab. 2.4c: E series rating table - continued

Size	Reduction ratio	Max. lost motion	Average angular transmission error 1) 6)	Hysteresis	Max. moment 2) 3)	Rated radial force 2)	Max. axial force 2) 4)	Input inertia 7)	Weight 7)
	i	LM [arcmin]	ATE [arcsec]	H [arcmin]	$M_{c\ max}$ [Nm]	$F_{r}$ [kN]	$F_{a\ max}$ [kN]	$I$ [ $10^{-4}$ kgm <sup>2</sup> ]	m [kg]
<b>TS 70</b>	<b>41</b>	<1.5	±30	<1.5	142	2.8	4.1	0.061	1
	75								
<b>TS 80</b>	<b>37</b>	<1.5	±30	<1.0	280	4.8	6.9	0.03	1.6
	85								
<b>TS 110</b>	<b>67</b>	<1.0	±17	<1.0	740	9.3	13.1	0.16	3.7
	119								
<b>TS 140</b>	<b>69</b>	<1.0	±17	<1.0	1 160	11.5	17	0.67	5.8
	115								
<b>TS 170</b>	33	<1.0	±17	<1.0	2 430	19.2	27.9	1.15	10.8
	59								
	<b>125</b>								
<b>TS 200</b>	49	<1.0	±15	<1.0	3 300	21.1	31.7	2.6	17.2
	63								
	<b>125</b>								
<b>TS 220</b>	55	<1.0	±15	<1.0	4 400	22.5	35.5	4.8	22.4
	<b>125</b>								

**IMPORTANT NOTES:**

- Instantaneous speed peak that may occur within the working cycle.
- Note please the temperature on the gear case that should not exceed significantly 60°C degrees.
- Load values in the table are valid for the nominal life of  $L_{10} = 6\ 000$  [Hrs].
- High precision reduction gears are preferred for intermittent cycles (S3-S8): the output speed in applications is inverted-variable. The continuous mode cycle (S1) is needed to be consulted with the manufacturer.
- Dimensional pictures of the E series reduction gears are listed in the catalogue without sealing.
- Sealing options are described in the chapter Assembly instructions.
- Please consult the maximum speed in a duty cycle with the manufacturer.
- The values in the table refer to the nominal operating temperature.

**The ratios highlighted in bold are recommended by SPINEA as optimal versions in terms of price and delivery.**





**TS 110 - i - E - P 14**

INPUT SIDE VIEW

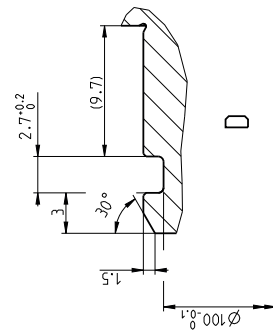
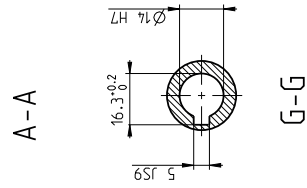
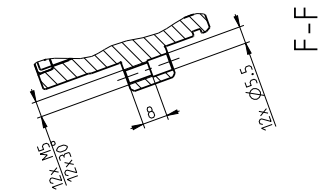
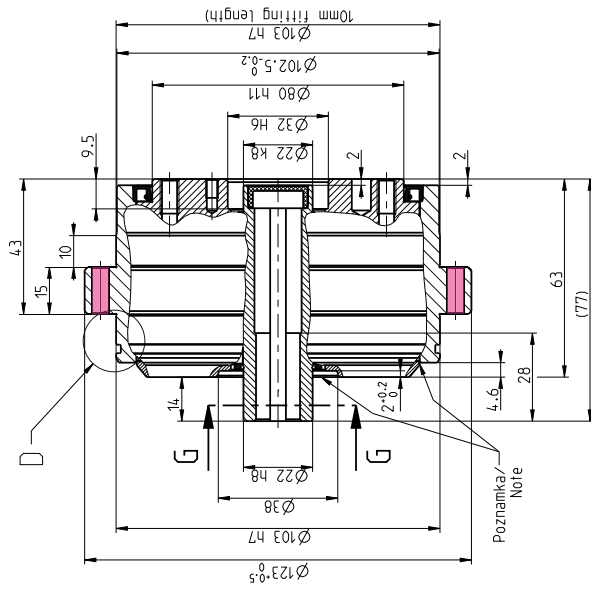
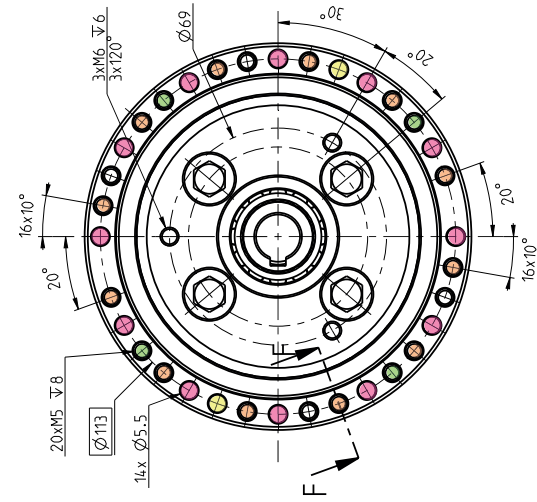

**TS 110 - i - E - P 14**

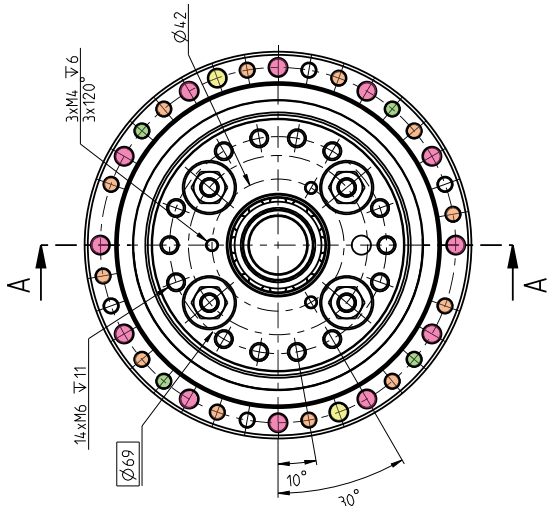

1. Use only standardized components, such as ring seals, bolts, etc.
2. Right to change without prior notice reserved.
3. Unsealed space, see the installation instructions in the TS Catalogue.



INPUT SIDE VIEW

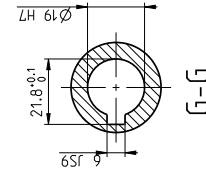
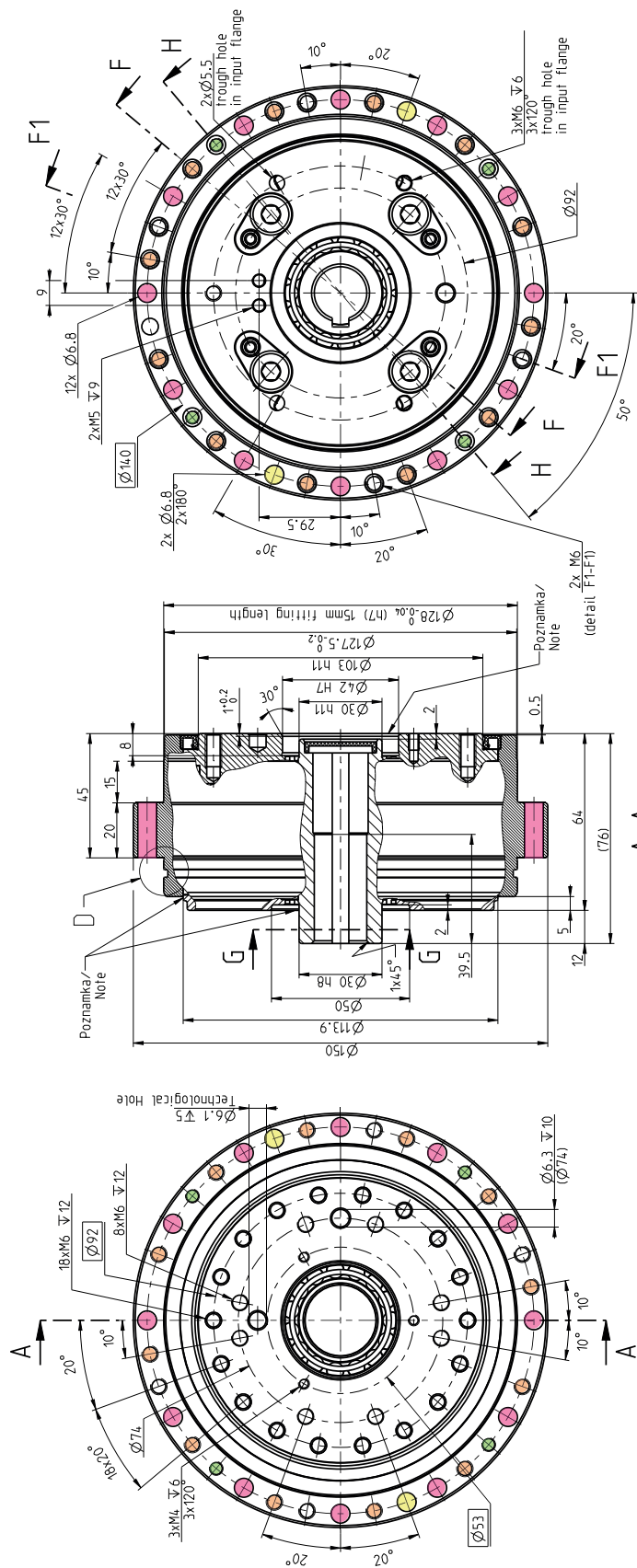

G-G

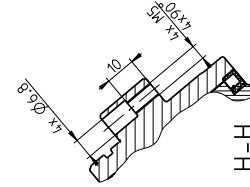

H-H

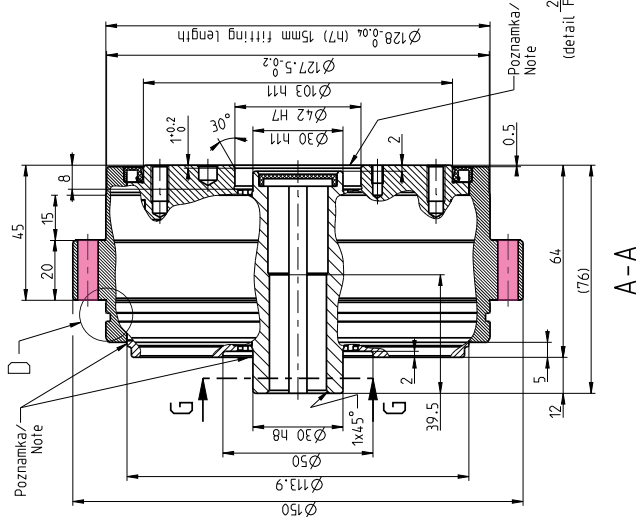

A-A

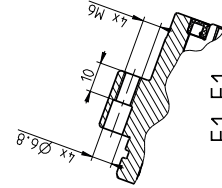

F1-F1

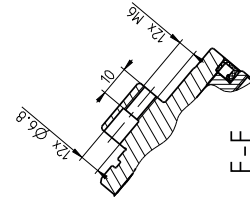

F-F

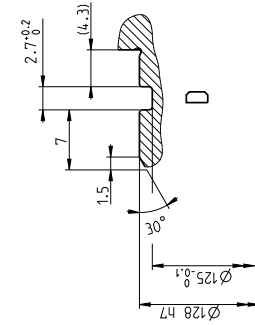

D

1. Use only standardized components, such as ring seals, bolts, etc.
2. Right to change without prior notice reserved.
3. Unsealed space, see the installation instructions in the TS Catalogue.





**TS 220 - i - E - P 28**

INPUT SIDE VIEW

**TS 220 - i - E - P 28**

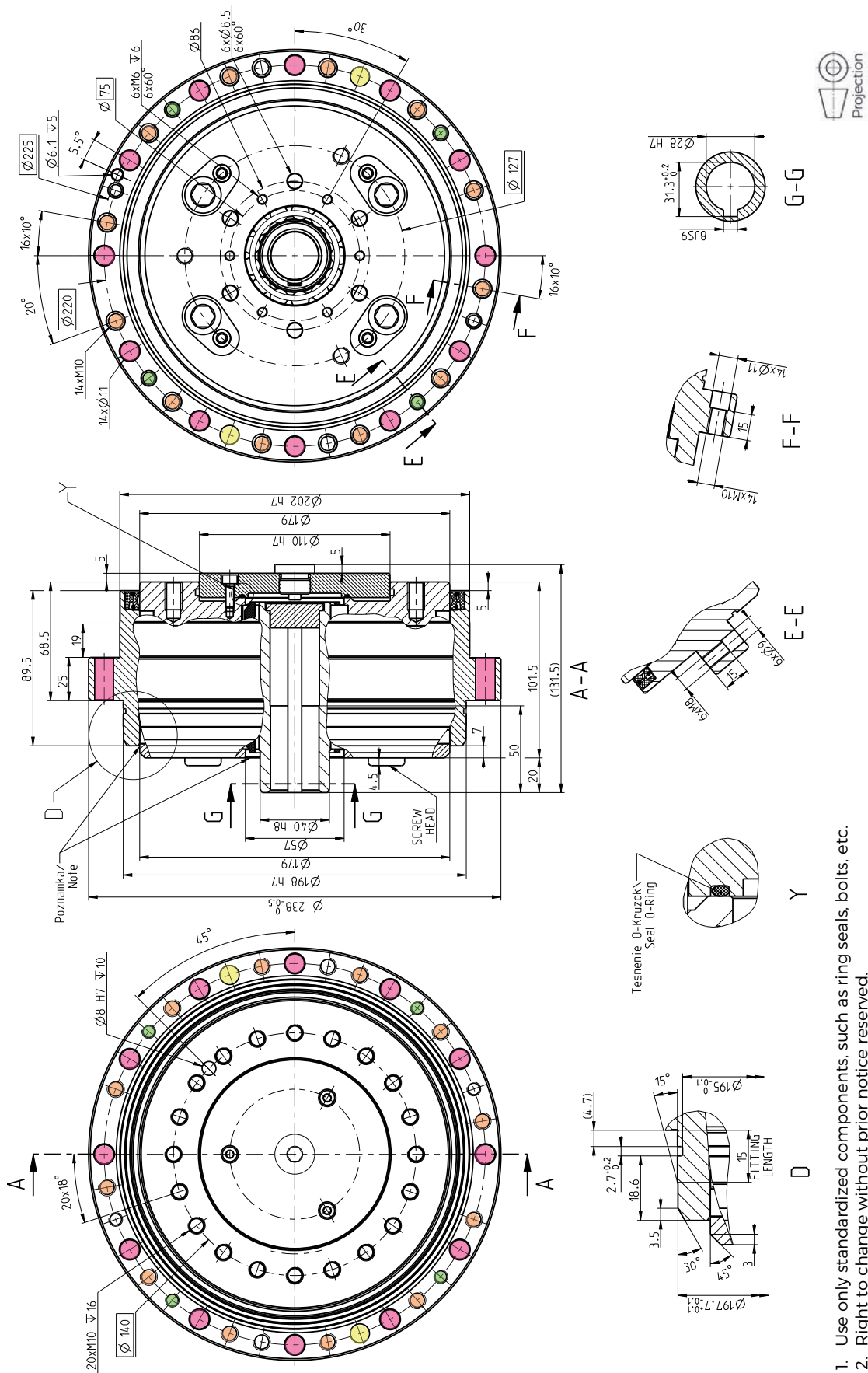

1. Use only standardized components, such as ring seals, bolts, etc.
2. Right to change without prior notice reserved.
3. Unsealed space, see the installation instructions in the TS Catalogue.

Schweiz

**Nozag AG**

Barzloostrasse 1  
CH-8330 Pfäffikon/ZH

Telefon +41 44 805 17 17

Aussendienst Westschweiz  
Telefon +41 79 886 76 83

[www.nozag.ch](http://www.nozag.ch)  
[info@nozag.ch](mailto:info@nozag.ch)