

T series

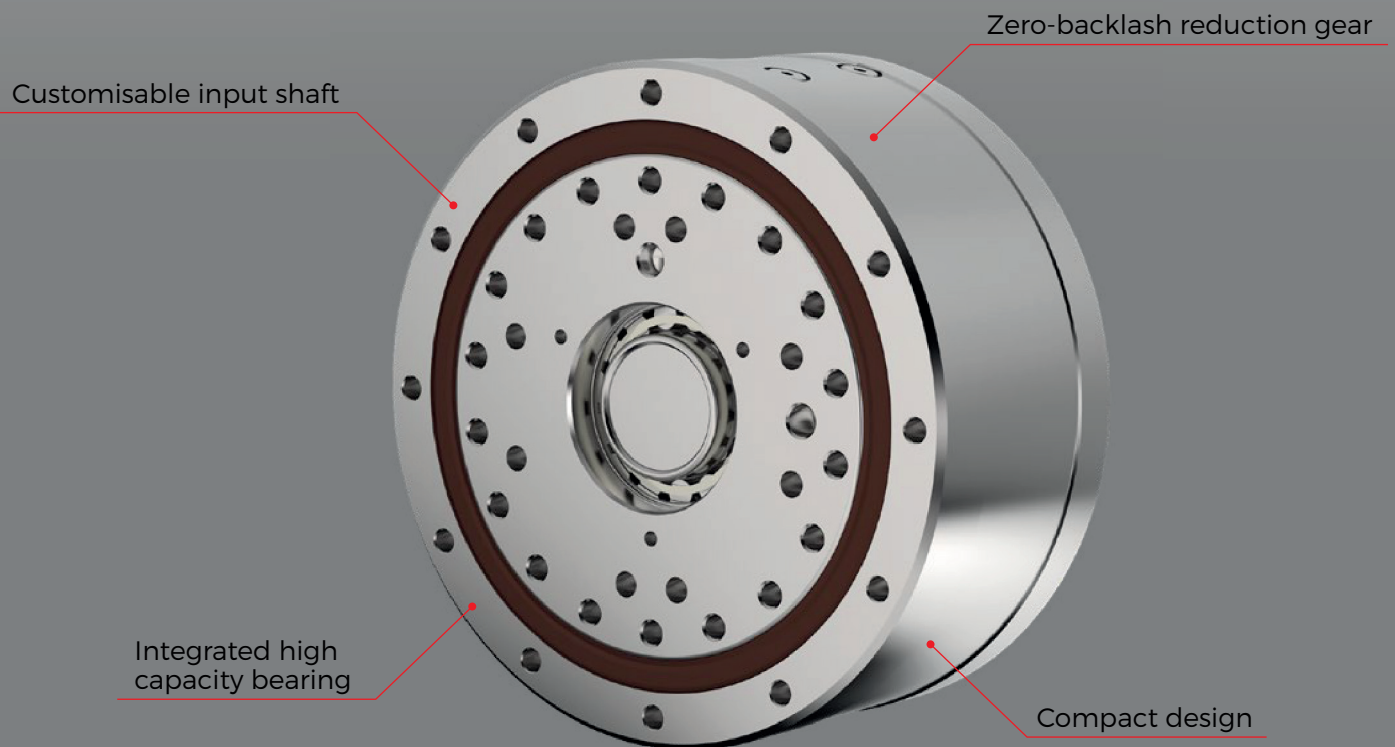

EXCELLENCE IN PERFORMANCE

2.3 T SERIES



Advantages

- zero- backlash reduction gear
- high moment capacity
- excellent positioning accuracy and positioning repeatability
- high torsional and tilting stiffness
- small dimensions and weight
- high reduction ratios
- long lifetime
- easy assembly

The **T series** represents a wide range of TwinSpin® high precision reduction gears with a cylindrical shaped case. The T series high precision reduction gears comprise an accurate reduction mechanism and a high-capacity radial and axial cylindrical roller bearings. This design of reduction gears allows the mounting of the load directly on the output flange or the case without the need of additional bearings. The T series high precision reduction gears are characterized by a modular design, which allows the mounting of your desirable type of motor to the reduction gear by means of a motor connection flange. The T series includes TwinSpin® high precision reduction gears that are not completely sealed; an inlet flange and a gasket kit have to be used for the sealing. Upon the customer's request, SPINEA is able to supply a completely sealed reduction gear with a flange according to the customer's motor.

Tab. 2.3a: T series features

Case	a) TB- threaded holes in the case 1) b) TC- threaded and through holes in case 2
Input flange connection	The shaft sealing / adapter flange is offered in the following versions: a) motor connection flange b) sealed input cover c) without a flange
Input shaft design	The input shaft is offered in the following versions: a) shaft with a keyway b) according to a special request
Installation and operation characteristics	A wider range of modular configurations

1) Valid for TS 60, TS 70, TS 80, TS 110, TS 140

2) Valid for TS 170, TS 200, TS 240, TS 300

Tab. 2.3b: T series ordering specifications

T series

TS - 200 - 125 - TC - P24					
Name	Size	Ratio	Series version	Shaft version	
				P (DIN 6885) ¹⁾	S ²⁾
TS	60	35, 47 , 63	TB	6	•
	70	41, 57, 75	TB	11	•
	80	37, 63 , 85	TB	8	•
	110	33, 67, 89 , 119	TB	14	•
	140	33 , 57, 87, 115 , 139	TB	19	•
	170	33, 59 , 83, 105 , 141	TC	24	•
	200	63 , 83, 125 , 169	TC	28	•
	240	37, 87, 121, 153	TC	24	•
	300	63 , 125, 191	TC	28	•

Note: An example of an ordering code of a modified TwinSpin® T series reduction gear with a motor flange:
 TS200 - 125 - TC - P24 - M235 - P231. The markings M235 and P231 for a specific modification are defined by the manufacturer.
 1) Max. dimension
 2) On request

Shaft version

P

Shaft with a keyway

S

Special shaft

Tab. 2.3c: T series rating table

Size	Reduction ratio	Rated output torque	Max. acceleration / deceleration torque	Permissible output torque at emergency stop	Rated input speed	Max. allowable input speed 9)	Tilting stiffness 1) 5)	Torsional stiffness 1) 6)	Max. no-load starting torque 8)	Max. back-driving torque 8)
	i	T _R [Nm]	T _{acc} [Nm]	T _{em} [Nm]	n _R [rpm]	n _{max} [rpm]	M _t [Nm/arcmin]	k _t [Nm/arcmin]	[Nm]	[Nm]
TS 60	35	37	74	185	2 000	4 000	27	3.5	0.16	9
	47					5 000			0.12	9
	63								0.12	10
TS 70	41	50	100	250	2 000	4 000	35	7	0.30	11
	57					5 000			0.15	12
	75								0.14	13
TS 80	37	78	156	390	2 000	4 000	62	9	0.35	14
	63					5 000			0.20	15
	85								0.12	16
TS 110	33	122	244	610	2 000	3 500	150	22	0.35	24
	67					3 900			0.35	28
	89					4 500			0.30	30
	119								0.20	33
TS 140	33	268	670	1 340	2 000	3 000	340	54	0.60	40
	57					3 200			0.40	40
	87					4 500			0.35	55
	115								0.35	65
TS 170	139	495	1 237	2 475	2 000		705	102	0.34	65
	33					3 000			2.00	75
	59					3 500			2.00	85
	83					4 000			1.40	100
	105					4 000			1.20	125
TS 200	141	890	2 225	4 450	2 000		1 070	178	0.40	125
	33					3 500			1.90	90
	83					4 000			1.80	120
	125					4 000			1.70	200
	169					4 500			0.90	210
TS 240	37	1 620	4 050	8 100	1 500	2 000	1 800	340	3.00	90
	87					3 000			1.75	160
	121					3 500			1.70	170
	153					3 700			1.20	180
TS 300	63	2 940	7 350	14 700	1 500	2 500	3 500	680	3.00	200
	125					3 200			2.00	250
	191					3 500			1.50	300

RIGHT TO CHANGE WITHOUT PRIOR NOTICE RESERVED

- 1) Mean statistical value. For further information see chapter Torsional stiffness, Tilting stiffness.
- 2) Load at output speed 15 rpm.
- 3) Moment $M_{c,max}$ value for $F_a=0$. If $F_a \neq 0$, see chapter 3.5.
- 4) Axial force F_a,max value for $M_c=0$. If $M_c \neq 0$, see chapter 3.5.
- 5) The parameter depends on the version of the high precision reduction gear.
- 6) The parameter depends on the version of the high precision reduction gear, ratio and lost motion.
- 7) The values of the parameters are informative. The exact value depends on the specific version of the high precision reduction gear.
- 8) Temperatures of the high precision reduction gear lower than 20°C will cause higher no-load starting or back driving torque.
- 9) Instantaneous speed peak that may occur within the working cycle.

Tab. 2.3c: T series rating table - continued

Size	Reduction ratio	Max. lost motion	Average angular transmission error 1) 6)	Hysteresis	Max. moment 2) 3)	Rated radial force 2)	Max. axial force 2) 4)	Input inertia 7)	Weight 7)
	i	LM [arcmin]	ATE [arcsec]	H [arcmin]	$M_{c\max}$ [Nm]	F_{rR} [kN]	$F_{a\max}$ [kN]	I [10^{-4} kgm ²]	m [kg]
TS 60	35	<1.5	±36	<1.5	107	2.6	3.7	0.006	0.86
	47								
	63								
TS 70	41	<1.5	±36	<1.5	142	2.8	4.1	0.061	1.05
	57								
	75								
TS 80	37	<1.5	±36	<1.0	280	4.8	6.9	0.03	1.64
	63								
	85								
TS 110	33	<1.0	±20	<1.0	740	9.3	13.1	0.16	3.76
	67								
	89								
	119								
TS 140	33	<1.0	±20	<1.0	1 160	11.5	17	0.67	6.45
	57								
	87								
	115								
TS 170	139	<1.0	±20	<1.0	2 430	19.2	27.9	1.15	11.07
	33								
	59								
	83								
TS 200	105	<1.0	±18	<1.0	3 300	21.1	31.7	2.6	17.23
	141								
	63								
	83								
TS 240	125	<1.0	±18	<1.0	5 720	30.8	47.3	3.9	31.15
	169								
	37								
	87								
TS 300	121	<1.0	±18	<1.0	12 000	45.3	68.1	11.2	55.73
	153								
	63								
	125	<1.0	±18	<1.0	12 000	45.3	68.1	11.2	55.73
	191								

IMPORTANT NOTES:

- Instantaneous speed peak that may occur within the working cycle.
- Note please the temperature on the gear case that should not exceed significantly 60°C degrees.
- Load values in the table are valid for the nominal life of $L_{10} = 6\ 000$ [Hrs].
- High precision reduction gears are preferred for intermittent cycles (S3-S8); the output speed in applications is inverted-variable. The continuous mode cycle (S1) is needed to be consulted with the manufacturer.
- Dimensional pictures of the T series reduction gears are listed in the catalogue without sealing.
- Sealing options are described in the chapter Assembly instructions.
- Please consult the maximum speed in a duty cycle with the manufacturer.
- The values in the table refer to the nominal operating temperature.

The ratios highlighted in bold are recommended by SPINEA as optimal versions in terms of price and delivery.

TS 80 - i - TB - P8

INPUT SIDE VIEW

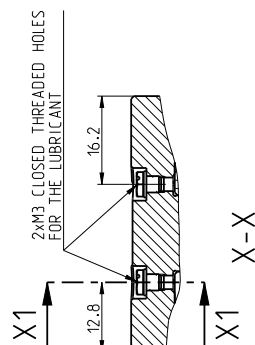
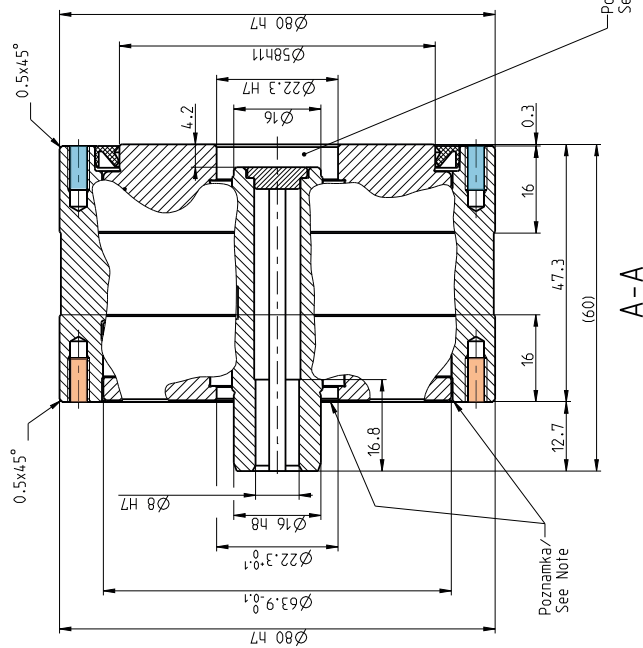
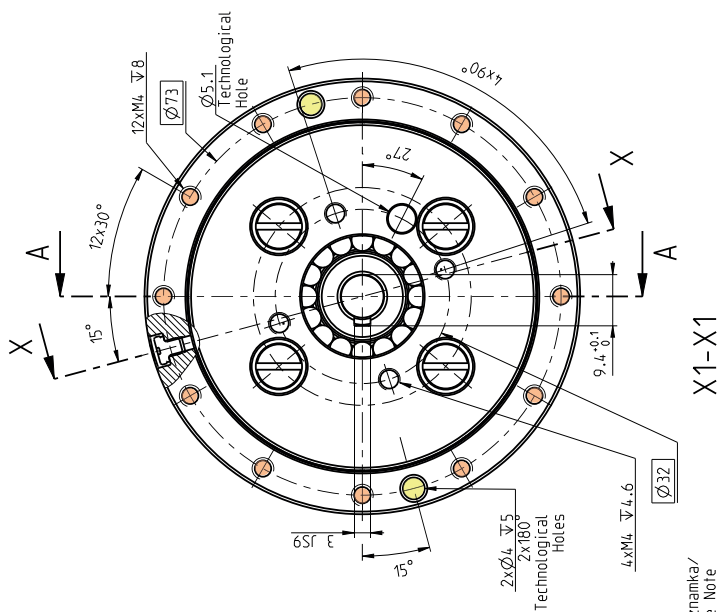

TS 80 - i - TB - P8

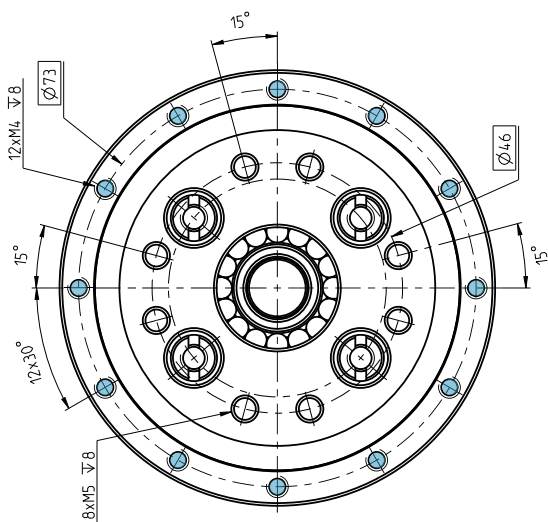

1. Use only standardized components, such as ring seals, bolts, etc.
2. Right to change without prior notice reserved.
3. Unsealed space, see the installation instructions in the TS Catalogue.

TS 170 - i - TC - P24

INPUT SIDE VIEW

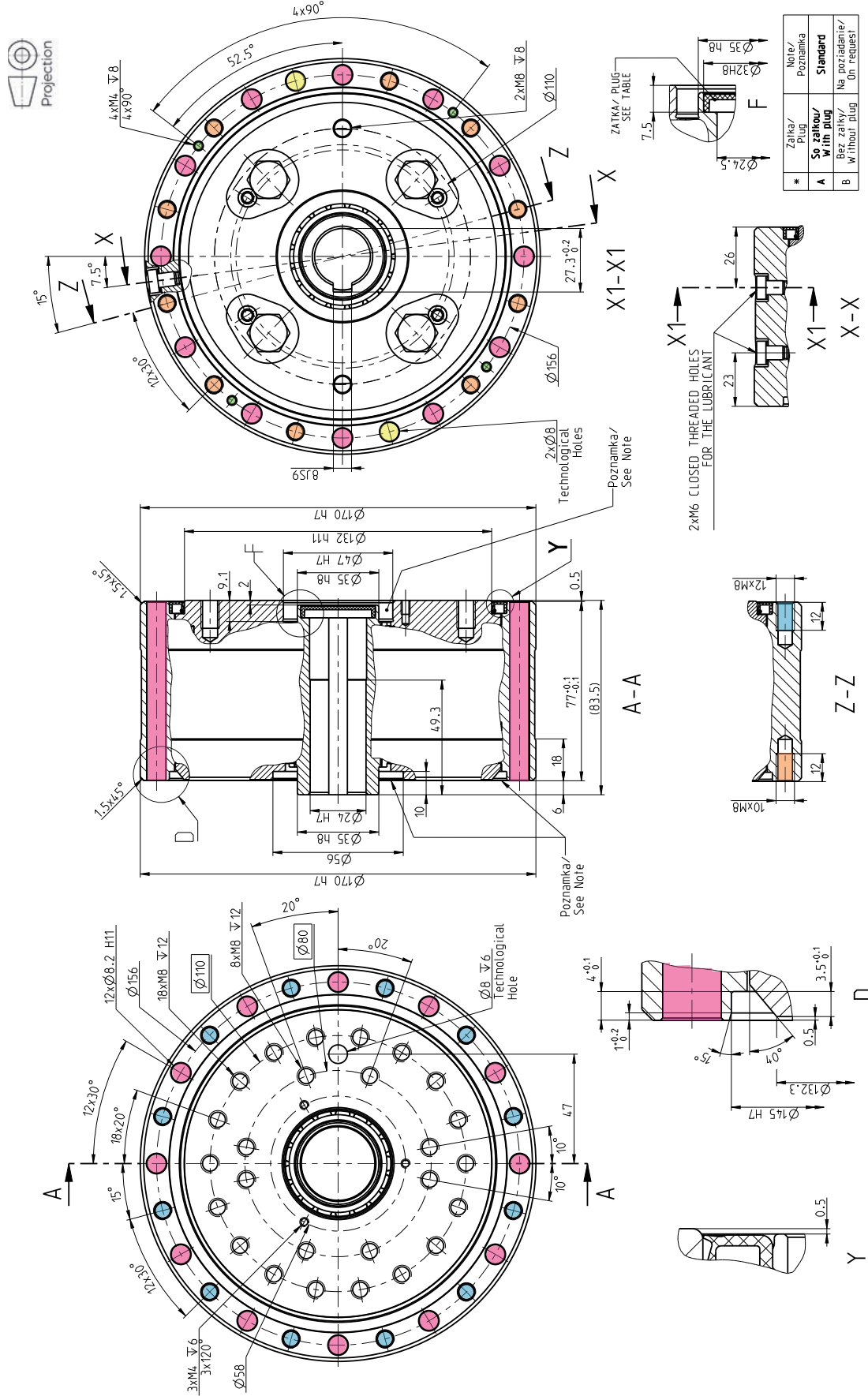

1. Use only standardized components, such as ring seals, bolts, etc.
2. Right to change without prior notice reserved.
3. Unsealed space, see the installation instructions in the TS Catalogue.

TS 240 - i - TC - P28

INPUT SIDE VIEW

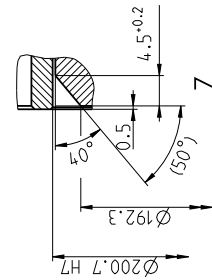
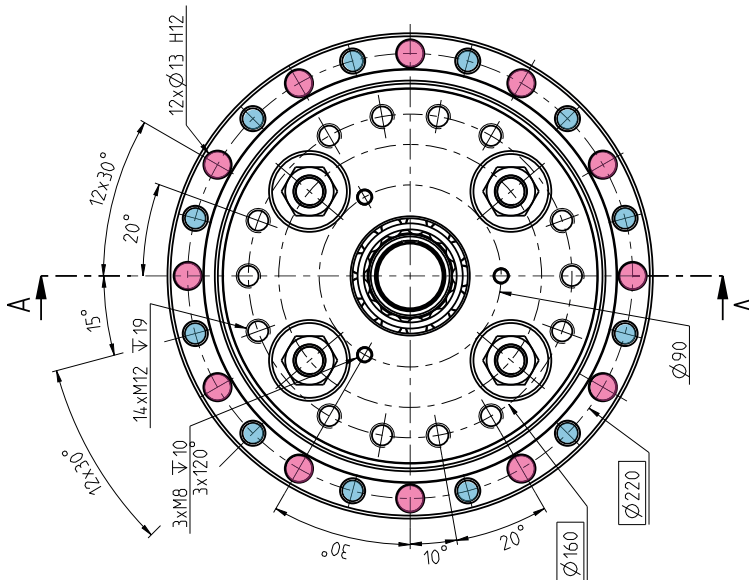
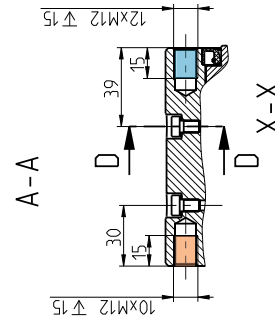
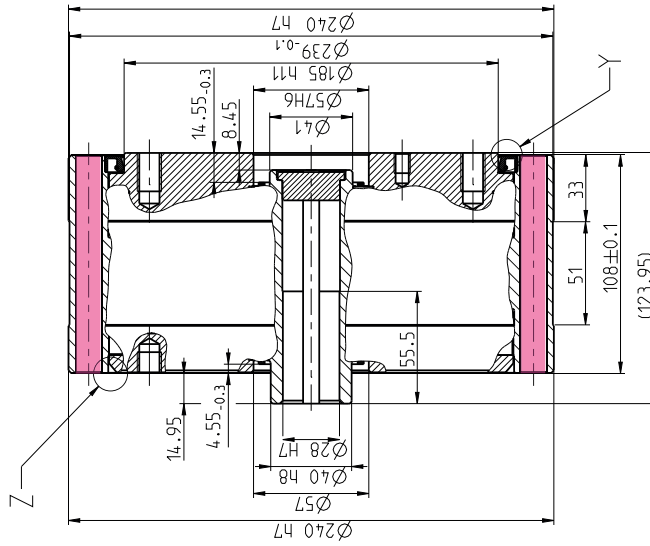
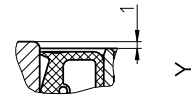
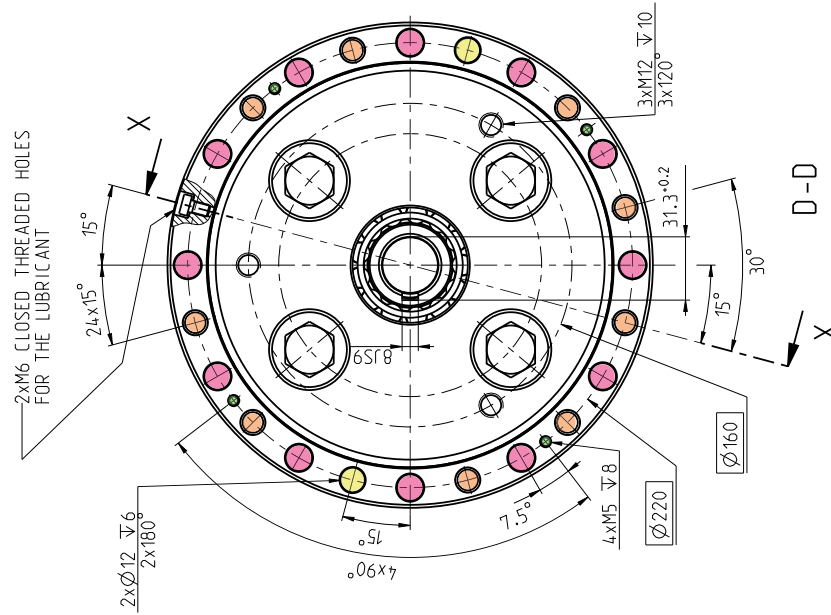

1. Use only standardized components, such as ring seals, bolts, etc.
2. Right to change without prior notice reserved.
3. Unsealed space, see the installation instructions in the TS Catalogue.

T series

Schweiz

Nozag AG

Barzloostrasse 1
CH-8330 Pfäffikon/ZH

Telefon +41 44 805 17 17

Aussendienst Westschweiz
Telefon +41 79 886 76 83

www.nozag.ch
info@nozag.ch