



HIGH PRECISION REDUCTION GEARS



HIGH PRECISION REDUCTION GEARS



G series

20 - 47



T series

48 - 63



E series

64 - 77



H series

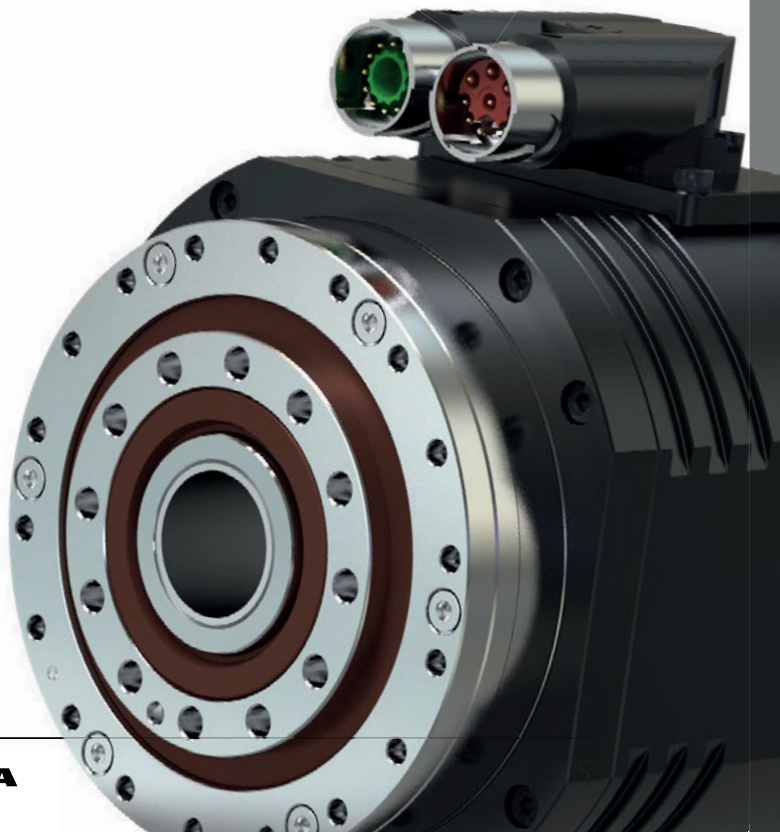
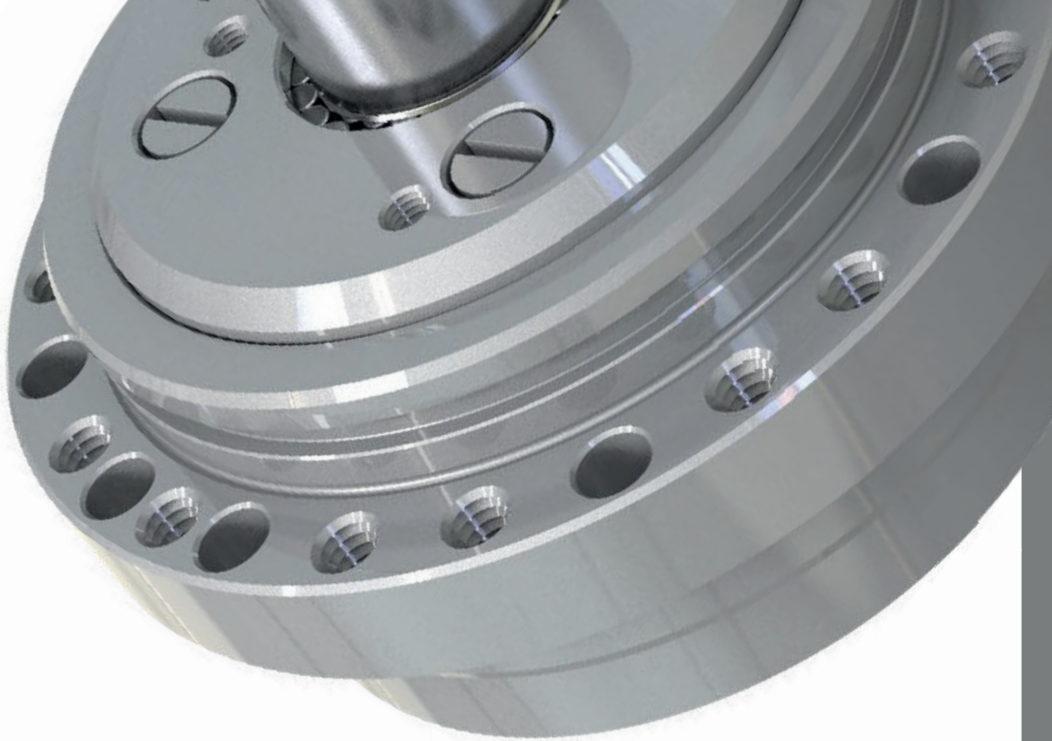
78 - 89



M series

90 - 99







| | |
|--|------------|
| I. CONTENTS | 6 |
| II. ABOUT US | 8 |
| 1. TwinSpin® - General information | 10 |
| Main parts description | 12 |
| Operating principle | 13 |
| Advantages | 14 |
| Applications | 18 |
| References | 19 |
| 2. TwinSpin® series | 20 |
| 2.1 G SERIES | 22 |
| 2.2 GH SERIES | 42 |
| 2.3 T SERIES | 50 |
| 2.4 E SERIES | 66 |
| 2.5 H SERIES | 80 |
| 2.6 M SERIES | 92 |
| 3. Performance characteristics | 100 |
| 3.1 G, GH, T, E, H, M series service life calculation | 100 |
| 3.2 M series maximum continuous input speed ($n_{c\ max}$) | 100 |
| 3.3 G, GH, T, E, H, M series maximum acceleration and braking torques | 100 |
| 3.4 G, GH, T, E, H, M series maximum emergency stop torque (T_{em}) | 100 |
| 3.5 Allowable radial-axial load and moment load on the output flange of the G, GH, T, E, H, M series | 100 |
| 3.6 G, GH, T, E, H, M series output flange tilting stiffness and deflection angle | 106 |
| 3.7 G, GH, T, E, H, M series lost motion, hysteresis and torsional stiffness | 106 |
| 3.8 G, GH, T, E, H, M series torsional vibrations | 107 |
| 3.9 G, GH, T, E, H, M series angular transmission accuracy | 108 |
| 3.10 G, GH, T, E, H, M series no-load starting torque | 108 |
| 3.11 G, GH, T, E, H, M series back-driving torque | 108 |
| 3.12 G, GH, T, E, H, M series maximum moment on the input shaft (M_{cin}) | 108 |
| 3.13 G series efficiency chart | 109 |
| 3.14 GH series efficiency chart | 112 |
| 3.15 G series no-load running torque | 113 |
| 3.16 GH series no-load running torque | 114 |
| 3.17 T, E, H, M series efficiency chart | 115 |
| 3.18 G, GH, T, E, H, M series rotation direction and reduction ratio | 117 |
| 4. TwinSpin® selection procedure | 118 |
| 4.1 G, GH, T, E, H, M series duty cycle | 118 |
| 4.2 G, GH, T, E, H, M series selection flowchart | 119 |
| 4.3 T, E, H, M selection example | 121 |
| 5. Assembly | 126 |
| 5.1 G, GH, T, E, H, M series assembly manual | 126 |
| 5.2 E series installation examples | 134 |
| 5.3 H series installation examples | 141 |
| 5.4 M series installation examples | 144 |
| 5.5 Lubrication, cooling, preheating | 148 |
| 5.6 Thermal conditions | 151 |
| 5.7 Motor flanges | 151 |
| 6. General information | 152 |
| 6.1 Maintenance | 152 |
| 6.2 Delivery conditions | 152 |
| 6.3 Transport and storage | 152 |
| 6.4 Warranty | 152 |
| 6.5 Final statement | 152 |
| 6.6 Cautions concerning the application of the TwinSpin® high precision reduction gear | 152 |
| 6.7 FAQ | 153 |



SPINEA

EXCELLENCE IN MOTION

SPINEA, s.r.o. is a modern Slovak engineering company, engaged in the development, manufacturing and sales of high-precision reduction gears, sold under the trademark TwinSpin®. An invention of a Slovak engineer was the impulse for the company establishment in 1994. The TwinSpin® high precision reduction gears are serially manufactured, based on the grant of an international patent. The TwinSpin® gears belong to a category of hi-tech products and represent a unique technical solution, which integrates radial-axial bearings with a high precision reduction gear into a single compact unit. The products of the company are suitable for applications, which require high reduction-gear ratio, high kinematic precision, zero-backlash motion, high torque capacity, high rigidity, compact design in a limited installation space as well as low weight. They are widely used in automation and industrial robotics, in the field of machine tools manufacturing, in navigation and camera equipment, medical systems and in many other fields.



SPINEA

TECHNOLOGIES

SPINEA Technologies, s.r.o. is a young research and development technology company, which is engaged in continuous development in the field of electrical actuators based on the G and TS-I bearing reducer platform, as well as development of customer-oriented mechatronic units. The company was founded at the end of 2012 through separation of the electric drives department from the parent company SPINEA s.r.o., while the impulse was to bring unique technologies, methods, and solutions for the industrial market, followed by their implementation into the production process.



1. TwinSpin® - General information

The TwinSpin® (TS) high precision reduction gears are based on a new reduction mechanism and a new design of the radial-axial output bearing. As a result, they represent a new generation of power transmission systems. The notion "TwinSpin®" indicates the full integration of a high precision trochoidal reduction gear and a radial-axial bearing in a single unit. This new transmission concept allows the use of the reduction gears directly in robot joints, rotary tables and wheel gears in various transport systems. The TwinSpin® high precision reduction gears are designed for applications requiring a high reduction ratio, high kinematic accuracy, low lost motion, high moment capacity and high stiffness of a compact design with limited installation space and low mass.

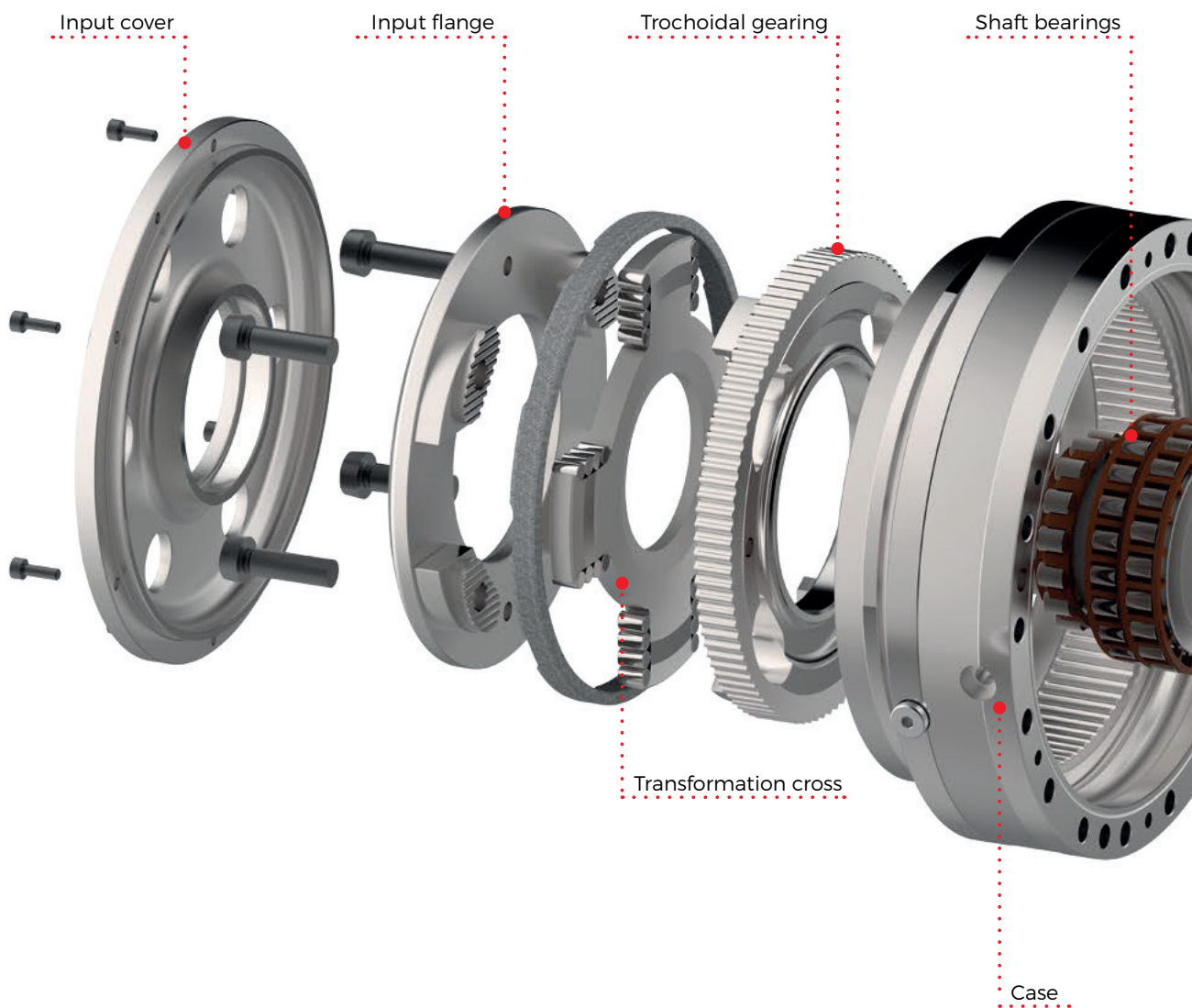
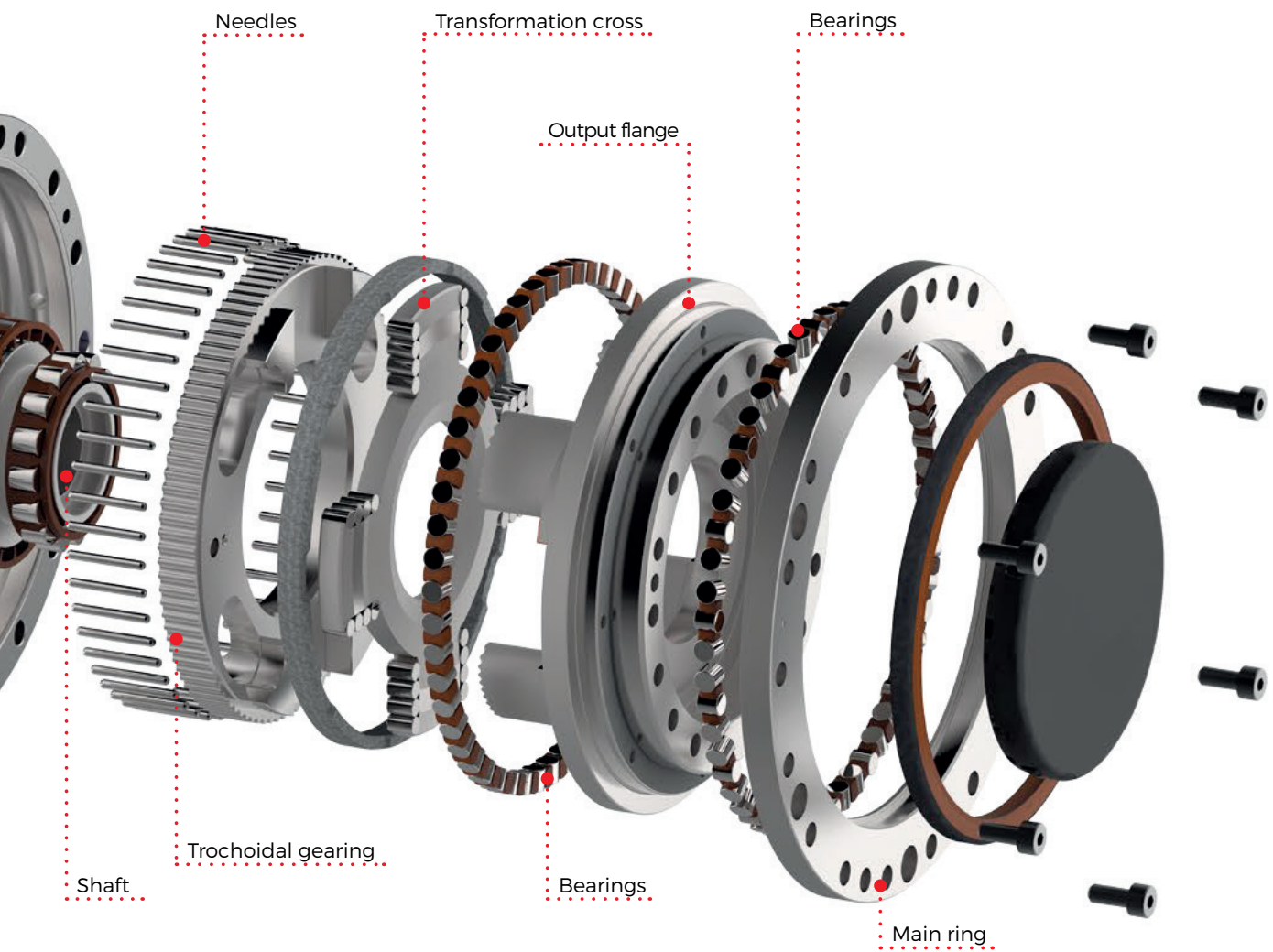


Fig. 1.a: TwinSpin® reduction gears components



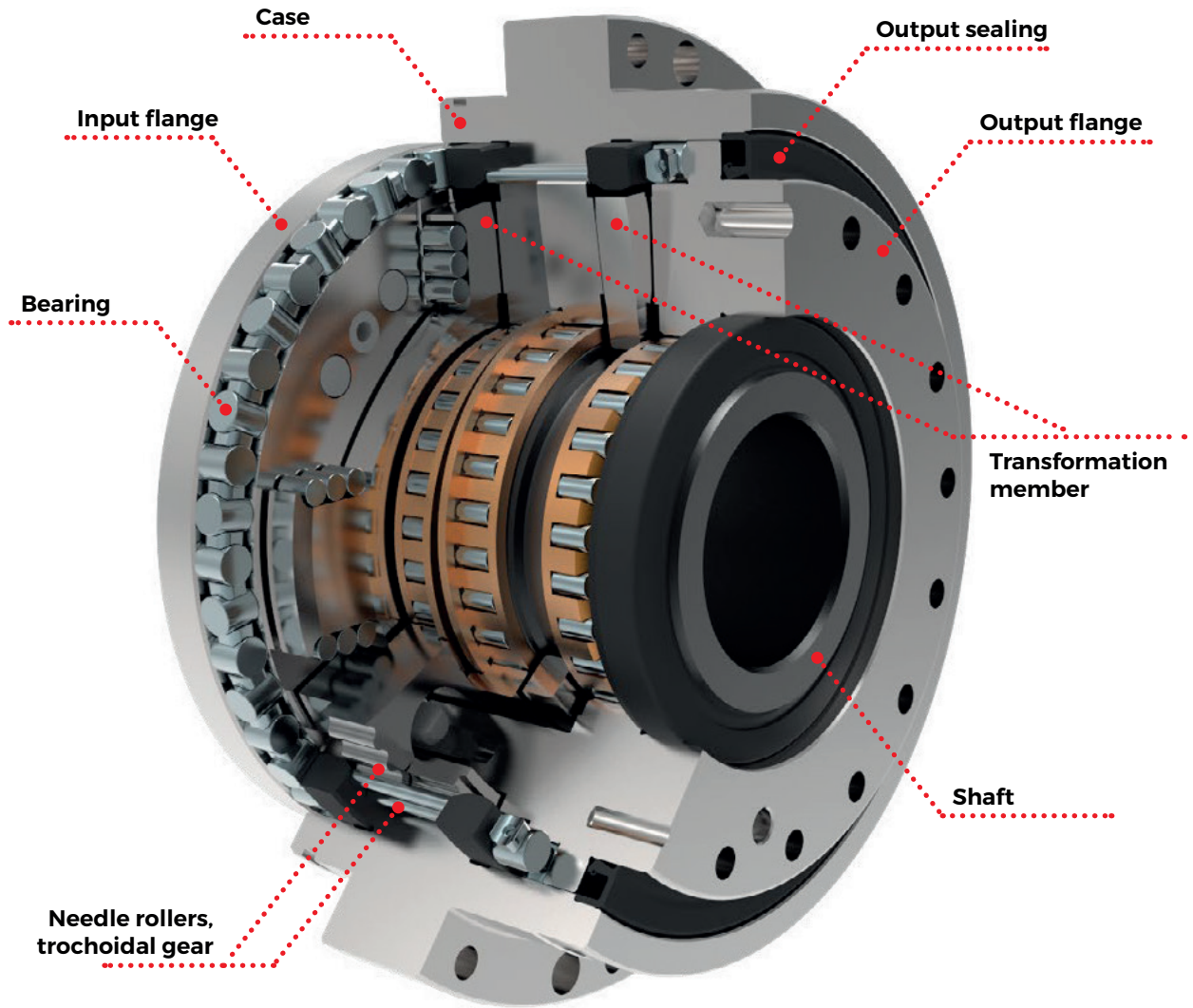


Fig. 1.b: TwinSpin® cross section

Output sealing

On the output flange side, it prevents internal contamination and lubricant leakage from the reduction gear.

Case

Incorporates the high capacity precision radial-axial output bearings integrated in the reduction gear.

Flanges

Input and output flanges are fixed together by fitted bolts, and rotate at reduced speed in the radial-axial output bearing relative to the case.

Shaft

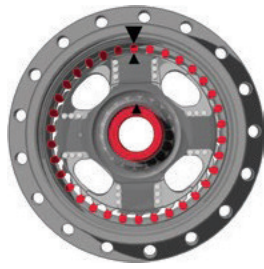
High-speed member of the reduction mechanism carried by roller bearings in the flanges. Bearing raceways are ground directly on the shaft and the flanges. The shaft eccentrics rotationally support the trochoidal gears via roller bearings.

Trochoidal gearing

Their trochoidal profile with almost 50% simultaneous meshing ensures transmission of high torque and backlash-free performance of the reduction gear.

Transformation member

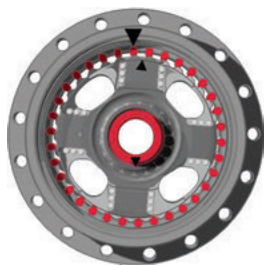
Transforms the planetary motion of the trochoidal gears to the rotary motion of a pair of flanges.


 $\alpha=0^\circ$

The input shaft of the reduction gear is in zero point.


 $\alpha=90^\circ$

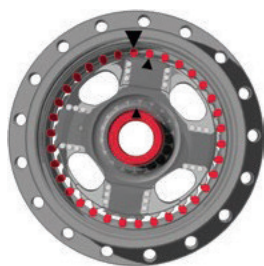
Rotation of the input shaft by 90° causes the revolution of the cycloidal gear (1/4 of spacing of the cycloidal tooth). Direction of the cycloidal gear rotation is opposite with regard to the rotation of input shaft.


 $\alpha=180^\circ$

Rotation of the input shaft by 180° causes the revolution of the cycloidal gear (2/4 of spacing of the cycloidal tooth).

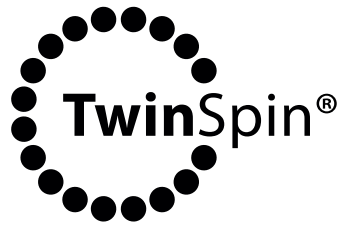

 $\alpha=270^\circ$

Rotation of the input shaft by 270° causes the revolution of the cycloidal gear (3/4 of spacing of the cycloidal tooth).


 $\alpha=360^\circ$

Rotation of the input shaft by 360° causes the revolution of the cycloidal gear (4/4 of spacing of the cycloidal tooth).

Fig. 1.1: Operating principle



Advantages

The TwinSpin® high precision reduction gears meet the requirements of even the most demanding customers across all industrial fields. With optimal price-performance ratio they reliably ensure parameters such as high precision, compactness, high tilting as well as torsional stiffness, low weight, low vibrations or wide range of gear ratios.

Exceptional precision

With the utilization of our own patented design the reduction gears represent an unrivalled precise solution, while at the same time keeping a wide range of dimensions and gear ratios.

High overload capacity, long lifetime

The reduction gears are characterized by easy implementation and excellent tilting and torsional stiffness parameters. At the same time they keep a trouble-free operation with exceptionally low noise and vibrations at a wide range of application environment temperature ranges. They rely on high resistance and overload capacity of the gearbox with integrated radial-axial bearings. Subsequently, your initial investment will project into maintenance cost saving, during entire utilization time.

Uniquely balanced design

TwinSpin® represents an integration of high load carrying reduction gear with a unique reduction mechanism and high load carrying output bearings into one compact unit. Small dimensions and first-class technical parameters lead to high utility value in an optimal performance, dimension and price ratio.

Technical support

Our expertly prepared team of specialists is at your disposal in order to solve any issues. The use of first-rate materials and the manufacturing process are guaranteed by ISO 9000 certificates, and are a fundamental prerequisite of the correct and reliable functioning of our products.

G series



T series



E series



H series



M series



Robotics

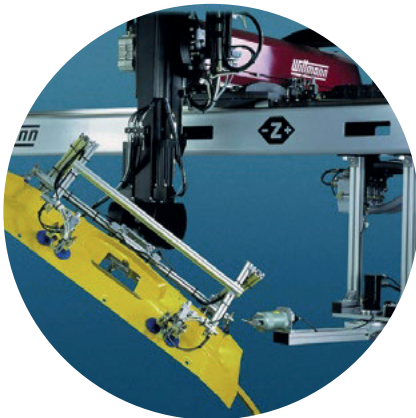
6-axis robots, scara robots, portal robots, gantry robots



ABB product

Automation and service robotics

Service robotics, general automation, assembly equipment, rotary tables, welding positioners



Machine tools

Turning and milling machines, grinding machines, bending machines, cutting machines (waterjet, laser, plasma, etc.) tool changers, pallet changers, rotary tables, cutting heads, woodworking machines, marble and stone machines, rotary transfer machines, woodworking machines



*Illustration image

Navigation and security

Radars, navigation equipment, surveillance optoelectronics systems, security and defense equipment, simulation systems



Medical equipment

Surgical robots, radiosurgery devices, medical and rehabilitation devices, scanners, dental milling machines, other medical equipment

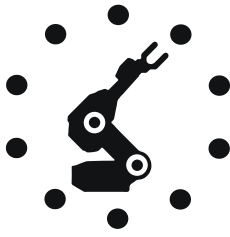


Other applications

Inspection, measuring and testing equipment, textile machines, packaging machines, semiconductor manufacturing, remote camera systems (film industry), calibration systems, rotary positioners in science projects

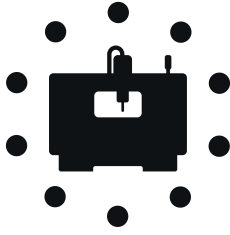


*Illustration image



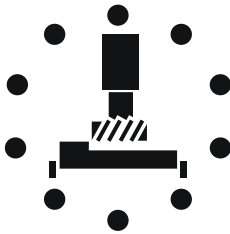
Robotics

6-axis robots, scara robots, portal robots, gantry robots



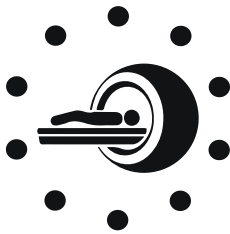
Automation and service robotics

Service robotics, general automation, assembly equipment



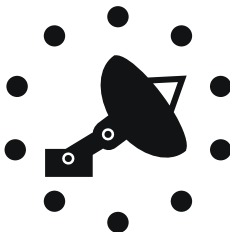
Machine tools

Turning and milling machines, grinding machines, bending machines, cutting machines, tool changers



Medical equipment

Medical and rehabilitation devices, scanners, dental milling machines, other medical equipment



Navigation and security

Radars, navigation equipment, surveillance and camera systems, security and defense equipment



Other applications

Measuring equipment, woodworking machines, textile machines, packaging machines, semiconductor manufacturing

KUKA



COMAU



AUTOMAZIONI INDUSTRIALI - ROBOT



Powering your potential



PROCESS CONCEPTION INGENIERIE
HIGH EFFICIENCY MACHING SYSTEMS



DENTAL CAD/CAM SYSTEMS



MILLTURN TECHNOLOGIES



ABB



SVS
satellite systems



DMG



FERMAT



ESTUN

ROBOTICS



TRUMPF





Friction under control

High precision output bearing

Robust design and overload capacity

High torque density



G series

EXCELLENCE IN PERFORMANCE

2.1 G SERIES



Advantages

- high tilting stiffness
- low friction
- high precision output bearing
- high torque density
- reduced lost motion settings
- high torque overload capacity

The **G series** a new generation of TwinSpin® high precision reduction gears with a new design of the main bearing and improved performance for the most demanding applications. G series brings increase in torque to weight ratio in comparison with the previous generation. Innovative design of main bearing reaches unprecedented tilting stiffness, high precision of the output bearing and modularity of design which allows customised solutions. Further improvements introduced with G series brings further friction reduction in transmission mechanism, lower hysteresis and low settings of Lost Motion, especially in small sizes. Finally with G series new sizes of reducers are introduced in standard and hollowshaft design to broaden portfolio and application range of TwinSpin® reducers.

Tab. 2.1a: G series features

| | |
|---|--|
| Case | Through holes in case |
| Input flange connection | The shaft sealing / adapter flange is offered in the following versions: a) motor connection flange b) sealed input cover c) without a flange |
| Input shaft design | The input shaft is offered in the following versions: a) shaft with a keyway b) according to a special request |
| Installation and operation characteristics | A wider range of modular configurations |

Tab. 2.1b: G series ordering specifications

TS - 225 - 55 - G - P24

| Name | Size | Ratio | Series version | Shaft version | |
|------|------|--|----------------|---------------|---|
| | | | | P (DIN 6885) | S |
| TS | 75 | 41, 63 , 75 | G | 9 | • |
| | 85 | 33 , 63 , 79 | G | 11 | • |
| | 95 | 43, 73, 95 | G | 14 | • |
| | 115 | 43 , 69, 123 | G | 14 | • |
| | 155 | 63, 109 , 133 | G | 19 | • |
| | 185 | 57 , 67 , 117 , 139 | G | 24 | • |
| | 225 | 55 , 69, 137 | G | 24 | • |

Note: An example of an ordering code of a modified TwinSpin® G series reduction gear with a motor flange:
 TS225 - 55 - G - P24 - M235 - P231. The markings M235 and P231 for a specific modification are defined by the manufacturer.

Shaft version


P

Shaft with a keyway


S

Special shaft

Note: Drawings shows maximum possible size of key-way applicable in each size of TwinSpin® reducer.

Tab. 2.1c: G series rating table

| Size | Reduction ratio | Rated output torque | Max. acceleration / deceleration torque | Maximum permissible torque at emergency / E-stop | Rated input speed | Maximum input speed 9) | Lost motion | Hysteresis | Angular transmission error 6) | No-load starting torque (max.) 8) |
|---------------|-----------------|---------------------|---|--|----------------------|------------------------|-------------|------------|-------------------------------|-----------------------------------|
| | i | T _R [Nm] | T _{acc} [Nm] | T _{em} [Nm] | n _r [rpm] | n _{max} [rpm] | LM [arcmin] | H [arcmin] | ATE [arcsec] | [Nm] |
| TS 75 | 41 | 35 | 70 | 175 | 2 000 | 4 800 | <1 | <1 | 72 | 0.15 |
| | 63 | | | | | 5 000 | | | | 0.1 |
| | 75 | | | | | 5 400 | | | | 0.1 |
| TS 85 | 33 | 75 | 150 | 375 | 2 000 | 4 400 | <1 | <1 | 72 | 0.25 |
| | 63 | | | | | 4 800 | | | | 0.2 |
| | 79 | | | | | 5 000 | | | | 0.2 |
| TS 95 | 43 | 85 | 170 | 425 | 2 000 | 4 000 | <1 | <1 | 72 | 0.35 |
| | 73 | | | | | 4 500 | | | | 0.3 |
| | 95 | | | | | 4 800 | | | | 0.3 |
| TS 115 | 43 | 173 | 346 | 865 | 2 000 | 4 200 | <1 | <1 | 60 | 0.5 |
| | 69 | | | | | 4 300 | | | | 0.45 |
| | 123 | | | | | 4 800 | | | | 0.4 |
| TS 155 | 63 | 460 | 1 150 | 2 300 | 2 000 | 3 400 | <1 | <1 | 40 | 0.8 |
| | 109 | | | | | 3 800 | | | | 0.6 |
| | 133 | | | | | 4 200 | | | | 0.6 |
| TS 185 | 57 | 780 | 1 950 | 3 900 | 2 000 | 3 500 | <1 | <1 | 30 | 1.4 |
| | 67 | | | | | 3 700 | | | | 1.4 |
| | 117 | | | | | 4 300 | | | | 1.2 |
| | 139 | | | | | 4 400 | | | | 1.2 |
| TS 225 | 55 | 1 270 | 3 175 | 6 350 | 2 000 | 3 200 | <1 | <1 | 30 | 1.8 |
| | 69 | | | | | 3 400 | | | | 1.5 |
| | 137 | | | | | 4 000 | | | | 1.4 |

RIGHT TO CHANGE WITHOUT PRIOR NOTICE RESERVED

- 1) Mean statistical value. For further information see chapter Torsional stiffness, Tilting stiffness.
- 2) Load at output speed 15 rpm and L₁₀ = 12 000 hrs.
- 3) Moment M_c value for F_a = 0. If F_a ≠ 0, see chapter 3.5.
- 4) Axial force F_{a,max} value for M_c = 0. If M_c ≠ 0 see chapter 3.5.
- 5) The parameter depends on the version of the high precision reduction gear.
- 6) The parameter depends on the version of the high precision reduction gear, ratio and lost motion.
- 7) The values of the parameters are informative. The exact value depends on the specific version of the high precision reduction gear.
- 8) Temperatures of the high precision reduction gear lower than 20°C will cause higher no-load starting or back driving torque.
- 9) Instantaneous speed peak that may occur within the working cycle.

Tab. 2.1c: G series rating table - continued

| Size | Reduction ratio | Max. backdriving torque 8) | Torsional stiffness 50-100% T _r 1) 6) | Tilting stiffness 1) 5) | Rated moment 2) 3) | Allowable moment | Allowable radial force 2) | Allowable axial force 2) 4) | Input inertia 7) | Weight 7) |
|---------------|-----------------|----------------------------|---|----------------------------|---------------------|------------------------|---------------------------|-----------------------------|--|-----------|
| | i | [Nm] | k _t [Nm/arcmin] | M _t [Nm/arcmin] | M _c [Nm] | M _{cmax} [Nm] | F _{rR} [kN] | F _{a max} [kN] | I [10 ⁻⁴ kgm ²] | m [kg] |
| TS 75 | 41 | 5 | 8.1 | 70 | 95 | 87 | 1.8 | 5.7 | 0.019 | 0.95 |
| | 63 | 8 | 8.2 | | | | | | | |
| | 75 | 10 | 8.4 | | | | | | | |
| TS 85 | 33 | 5 | 9.5 | 90 | 168 | 168 | 3.2 | 10.2 | 0.034 | 1.7 |
| | 63 | 15 | 10.8 | | | | | | | |
| | 79 | 20 | 10.8 | | | | | | | |
| TS 95 | 43 | 20 | 15 | 120 | 205 | 410 | 3.5 | 11.1 | 0.14 | 1.9 |
| | 73 | 27 | 15.3 | | | | | | | |
| | 95 | 38 | 15.5 | | | | | | | |
| TS 115 | 43 | 18 | 31 | 220 | 275 | 550 | 4 | 12.5 | 0.29 | 3.2 |
| | 69 | 30 | 31 | | | | | | | |
| | 123 | 42 | 32 | | | | | | | |
| TS 155 | 63 | 50 | 85 | 900 | 820 | 1 640 | 8.3 | 26.1 | 0.96 | 7.4 |
| | 109 | 80 | 88 | | | | | | | |
| | 133 | 115 | 90 | | | | | | | |
| TS 185 | 57 | 85 | 147 | 1 300 | 1 700 | 3 400 | 13.9 | 43 | 1.98 | 12.8 |
| | 67 | 90 | 148 | | | | | | | |
| | 117 | 120 | 150 | | | | | | | |
| | 139 | 135 | 152 | | | | | | | |
| TS 225 | 55 | 60 | 258 | 2 300 | 2 190 | 4 380 | 15.2 | 47.4 | 3.2 | 21.6 |
| | 69 | 80 | 300 | | | | | | | |
| | 137 | 230 | 308 | | | | | | | |

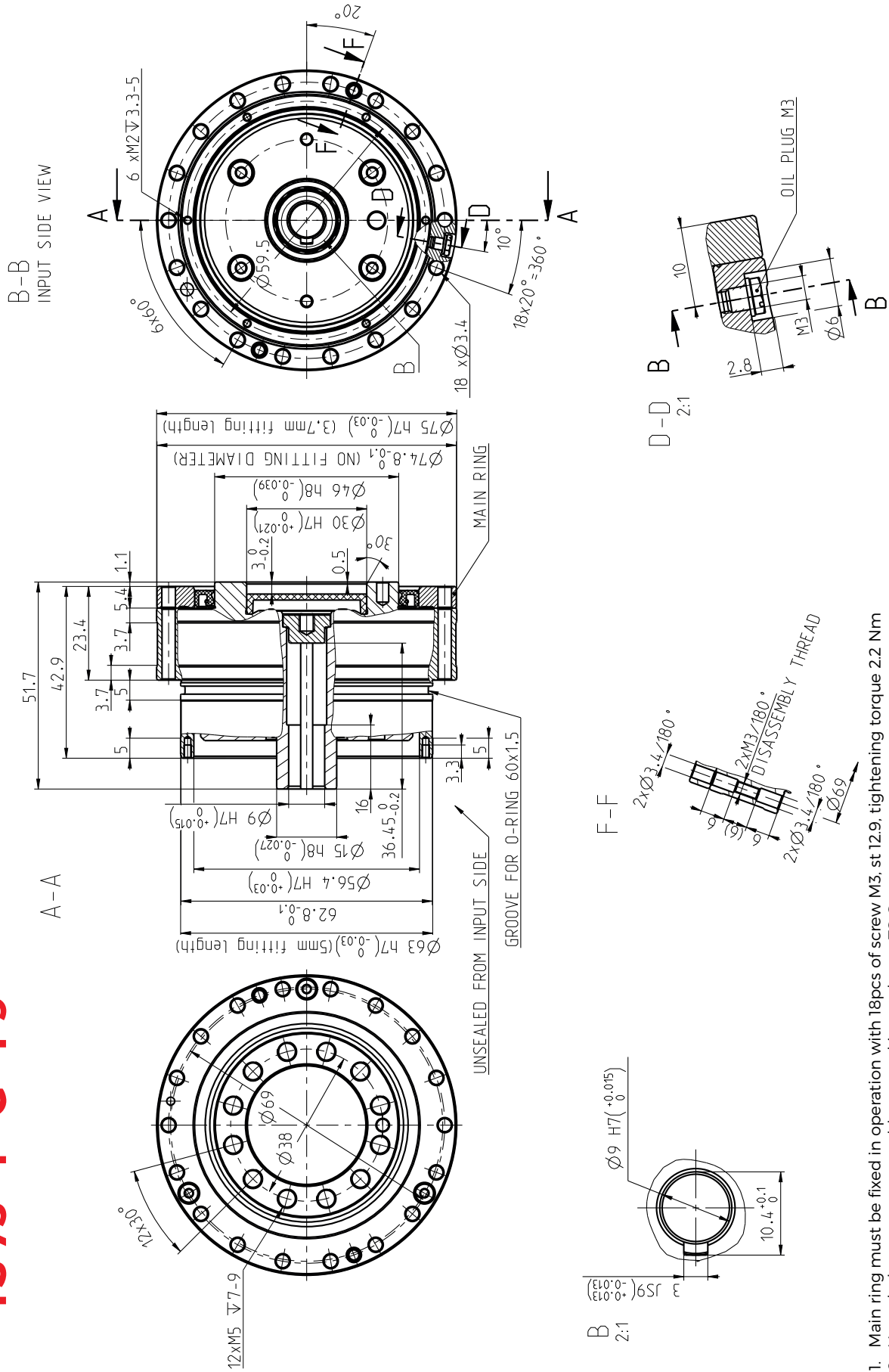
IMPORTANT NOTES:

- Load values in the table are valid for the nominal life of L₁₀ = 6 000 [Hrs].
- High precision reduction gears are preferred for intermittent cycles (S3-S8); the output speed in applications is inverted-variable.
- The continuous mode cycle (S1) is needed to be consulted with the manufacturer.
- If the output speed in application is less than 0.1 rpm please consult with the manufacturer.
- The values in the table refer to the nominal operating temperature.
- Please note the temperature on the gear case that should not exceed significantly 60°C.

The ratios highlighted in bold are recommended by SPINEA as optimal versions in terms of price and delivery.

TS 75 - i - G - P9

TS 75 - i - G - P9

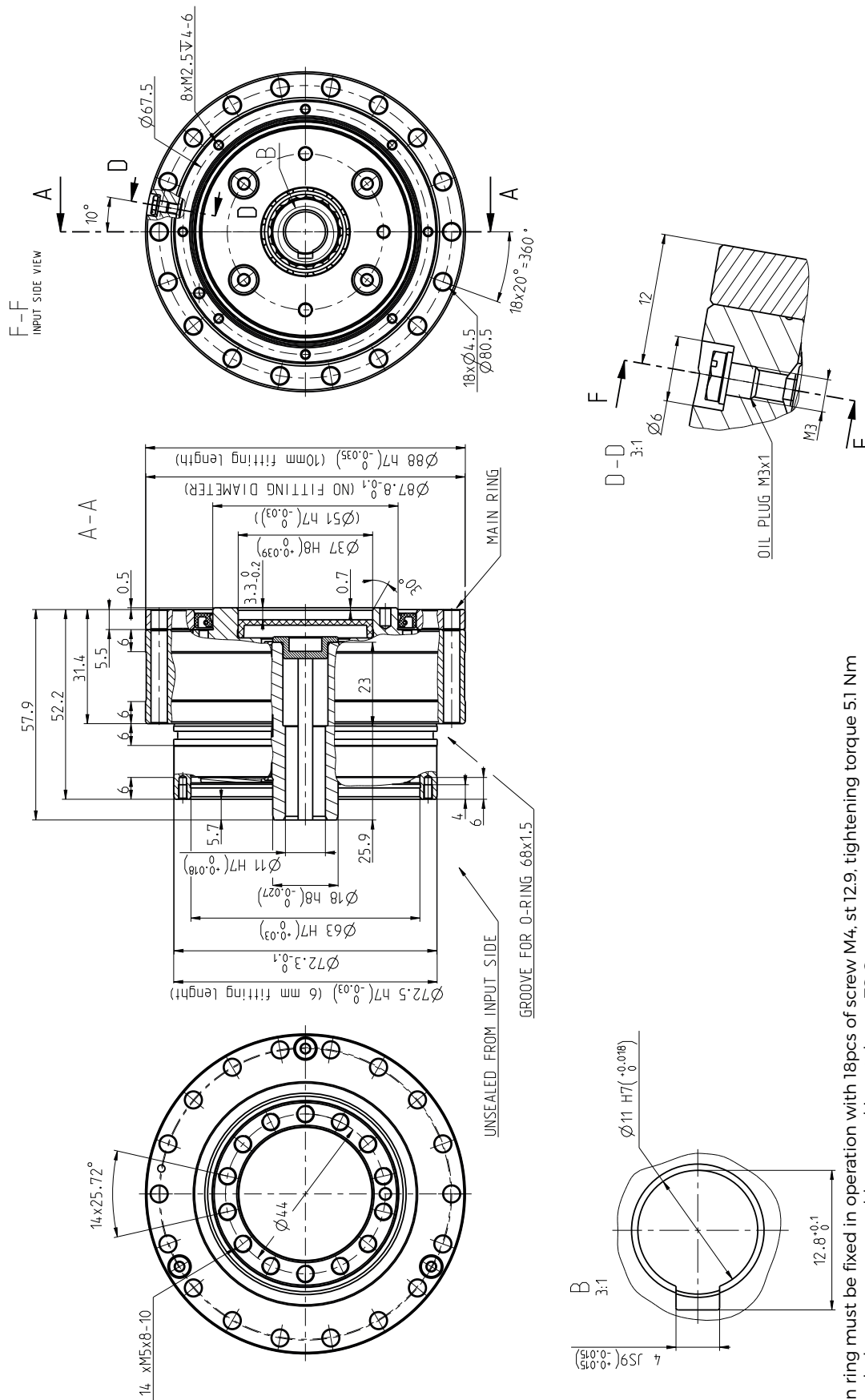


1. Main ring must be fixed in operation with 18pcs of screw M3, st 12.9, tightening torque 2.2 Nm
2. Unsealed space, see assembly manual in catalogue TS G
RECOMMENDATION FOR SEALING MOTOR FLANGE:
 Recommended tolerance for fitting diameter (ϕ 56.4 \pm 0.08)

TS 85 - i - G - P11

TS 85 - i - G - P11

G series

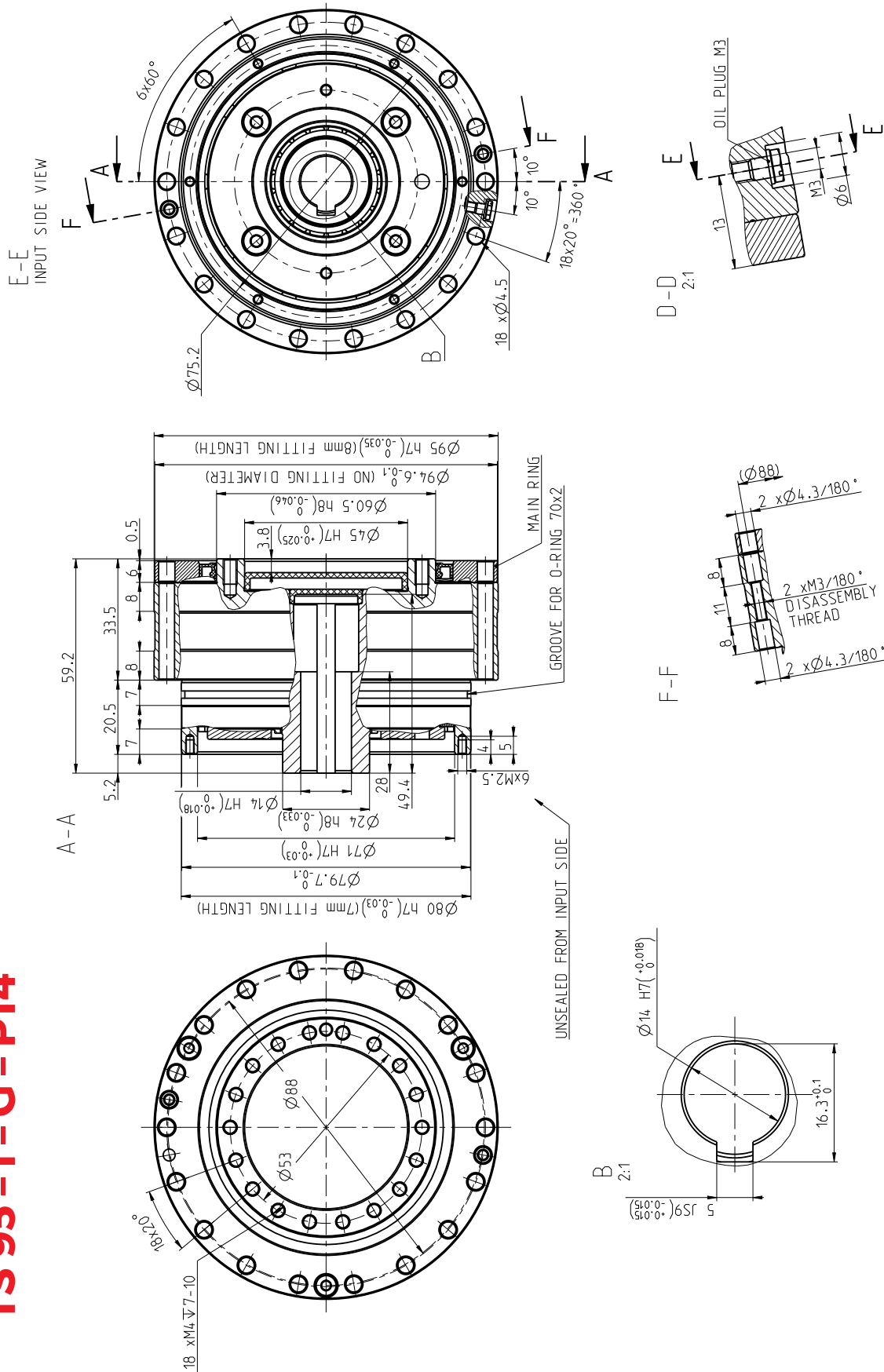


1. Main ring must be fixed in operation with 18pcs of screw M4, st 12.9, tightening torque 5.1 Nm
2. Unsealed space, see assembly manual in catalogue TS G
RECOMMENDATION FOR SEALING MOTOR FLANGE:
Recommended tolerance for fitting diameter ($\phi 63_{-0.06}^{+0.03}$)



TS 95 - i - G - P14

TS 95 - i - G - P14

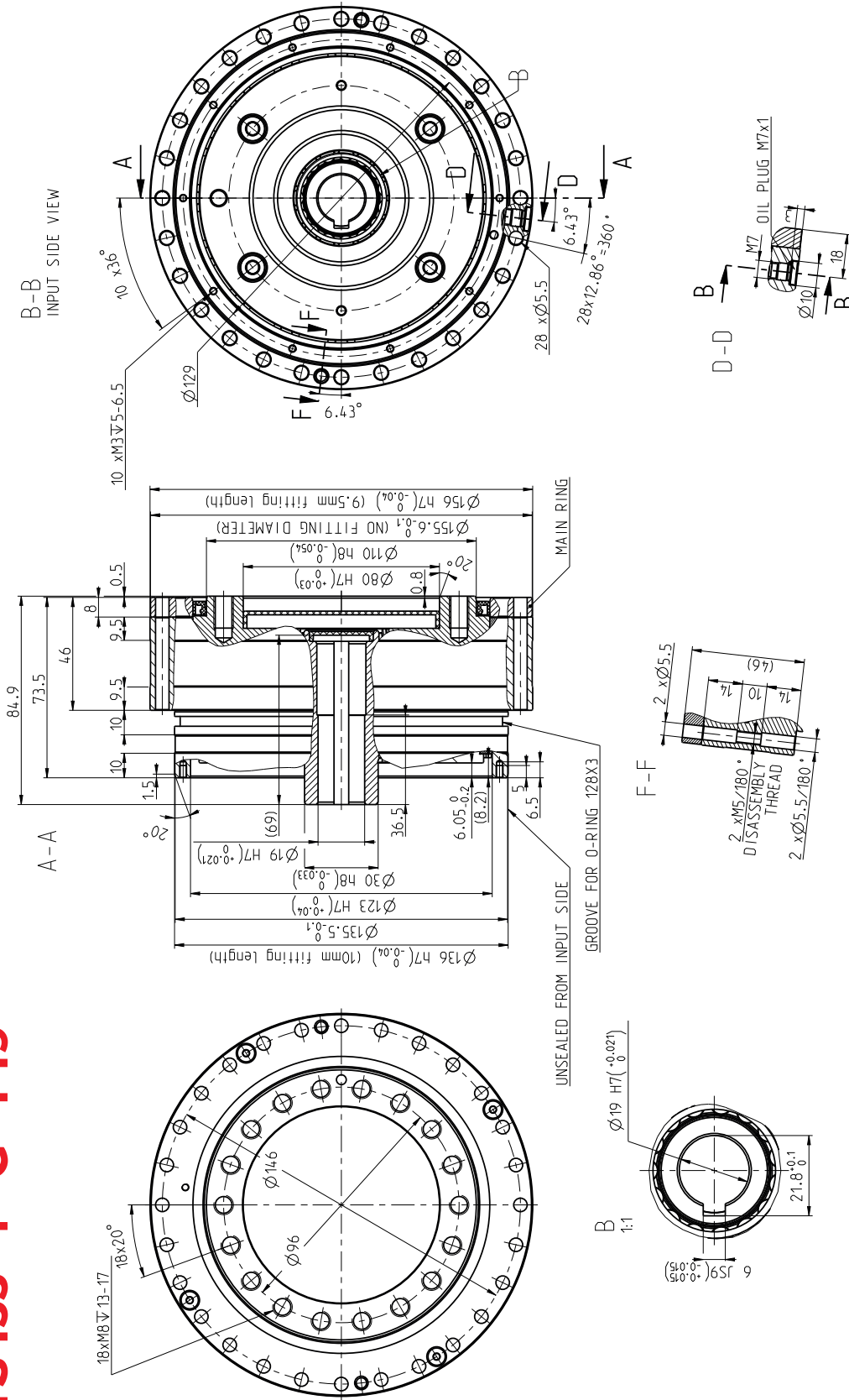


1. Main ring must be fixed in operation with 18pcs of screw M4, st 12.9, tightening torque 5.1 Nm
2. Unsealed space, see assembly manual in catalogue TS G
RECOMMENDATION FOR SEALING MOTOR FLANGE:
 Recommended tolerance for fitting diameter (Ø71_{-0.03})



TS 155 - i - G - P19

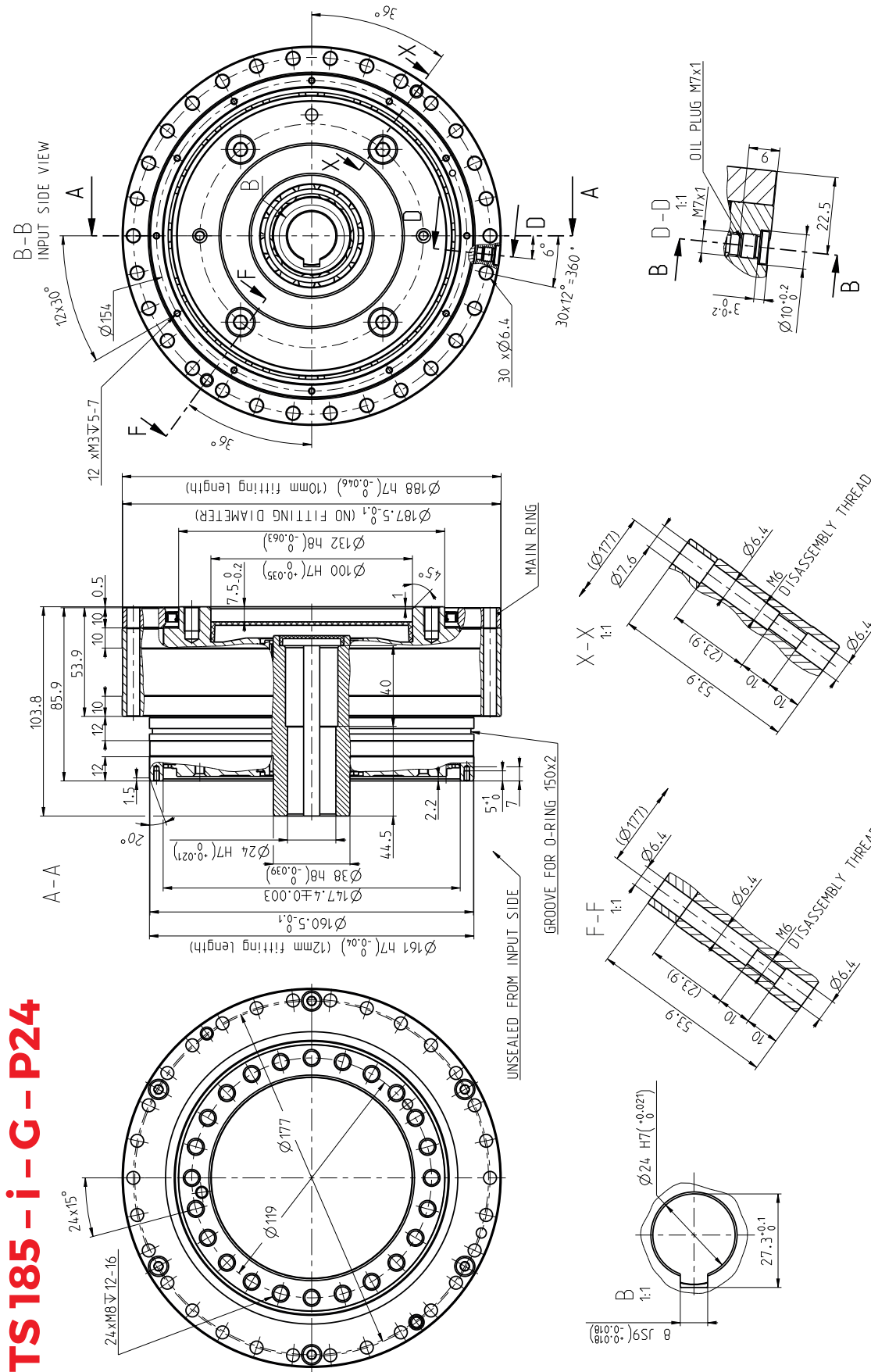
TS 155 - i - G - P19



1. Main ring must be fixed in operation with 28pcs of screw M5, st 12.9, tightening torque 8.4 Nm
2. Unsealed space, see assembly manual in catalogue TS G
RECOMMENDATION FOR SEALING MOTOR FLANGE:
 Recommended tolerance for fitting diameter (φ123^{+0.03}_{-0.06})

TS 185 - i - G - P24

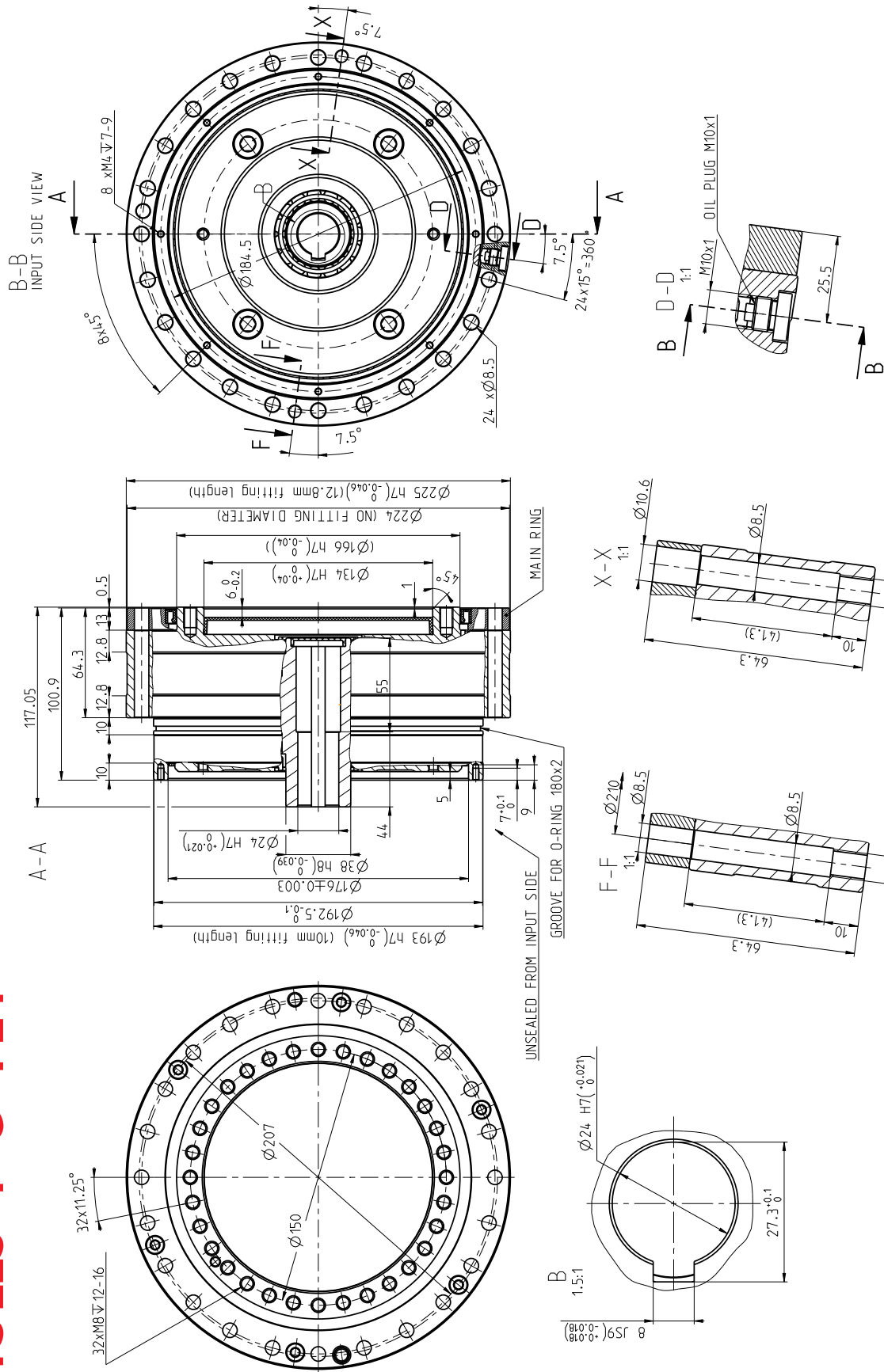
G series



1. Main ring must be fixed in operation with 30pcs of screw M6, st 12.9, tightening torque 14 Nm
2. Unsealed space, see assembly manual in catalogue TS G
RECOMMENDATION FOR SEALING MOTOR FLANGE:
 Recommended tolerance for fitting diameter $\phi 147.4_{-0.003}$

TS 225 - i - G - P24

TS 225 - i - G - P24

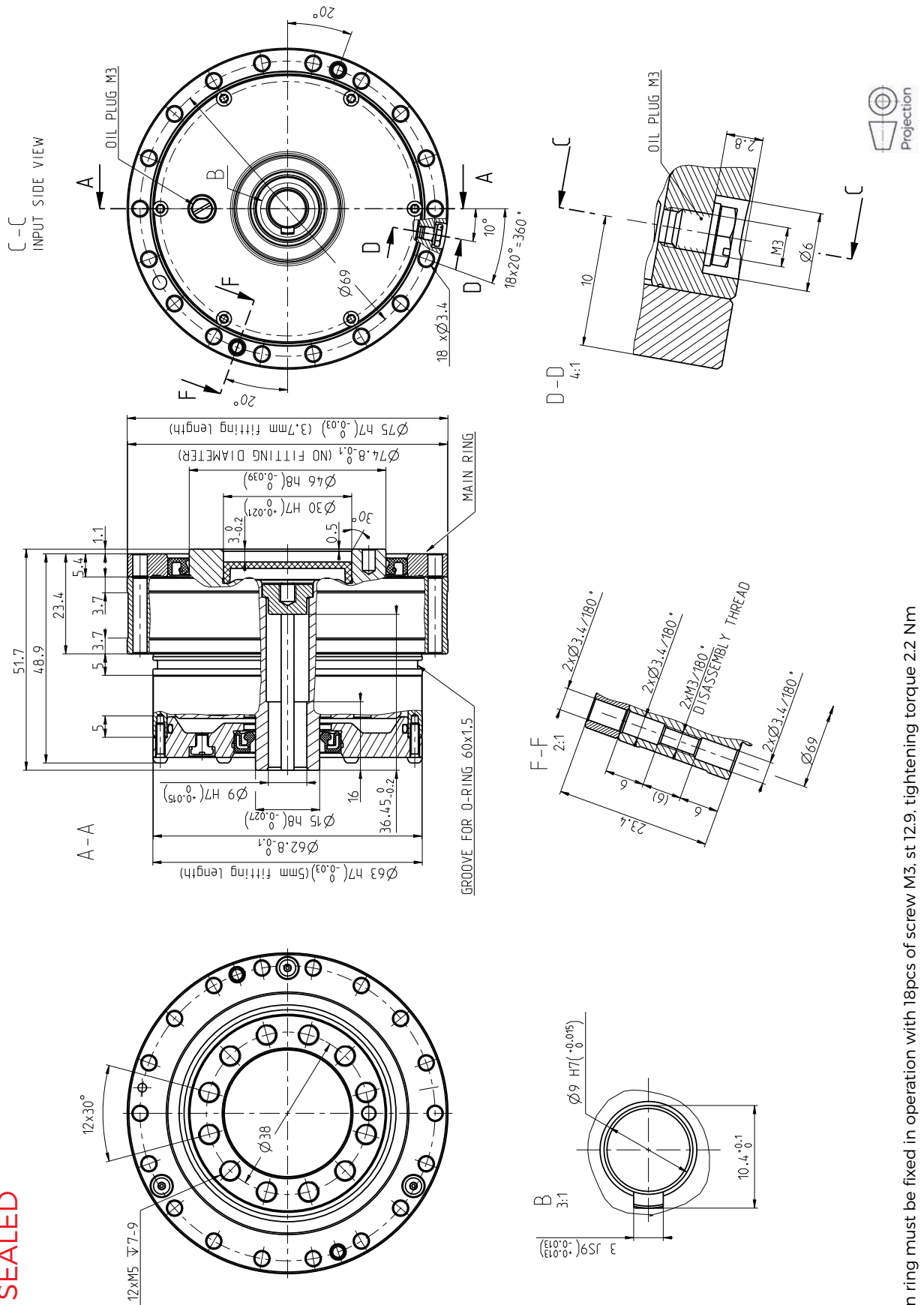


1. Main ring must be fixed in operation with 30pcs of screw M6, st 12.9, with tightening torque 14 Nm
2. Unsealed space, see assembly manual in catalogue TS G
RECOMMENDATION FOR SEALING MOTOR FLANGE:
Recommended tolerance for fitting diameter (Ø147.4^{+0.03}_{-0.06})



TS 75 - i - G - P9
SEALED

TS 75 - i - G - P9
SEALED

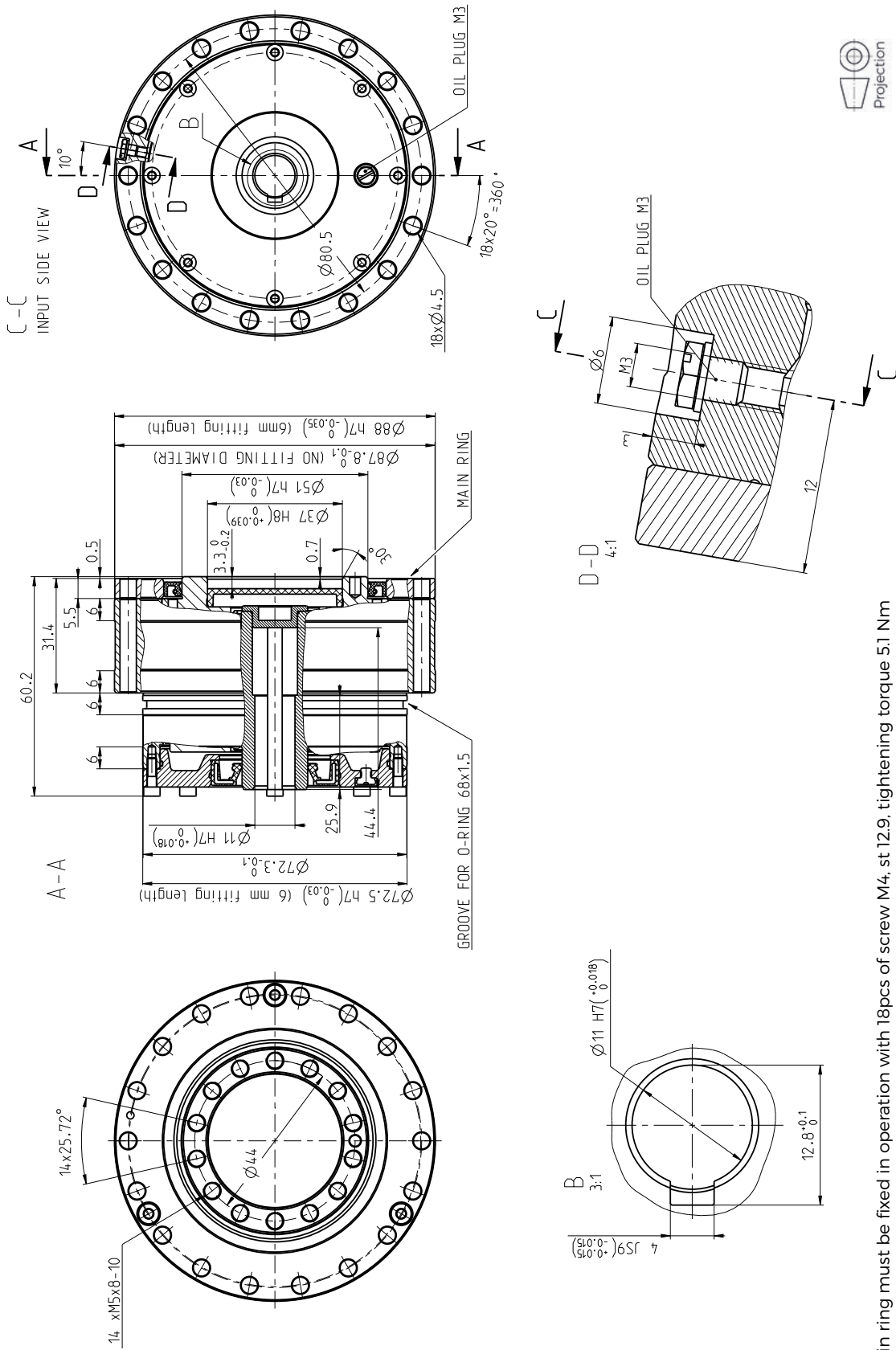


1. Main ring must be fixed in operation with 18pcs of screw M3, st 12.9, tightening torque 2.2 Nm

TS 85 - i - G - P11
SEALED



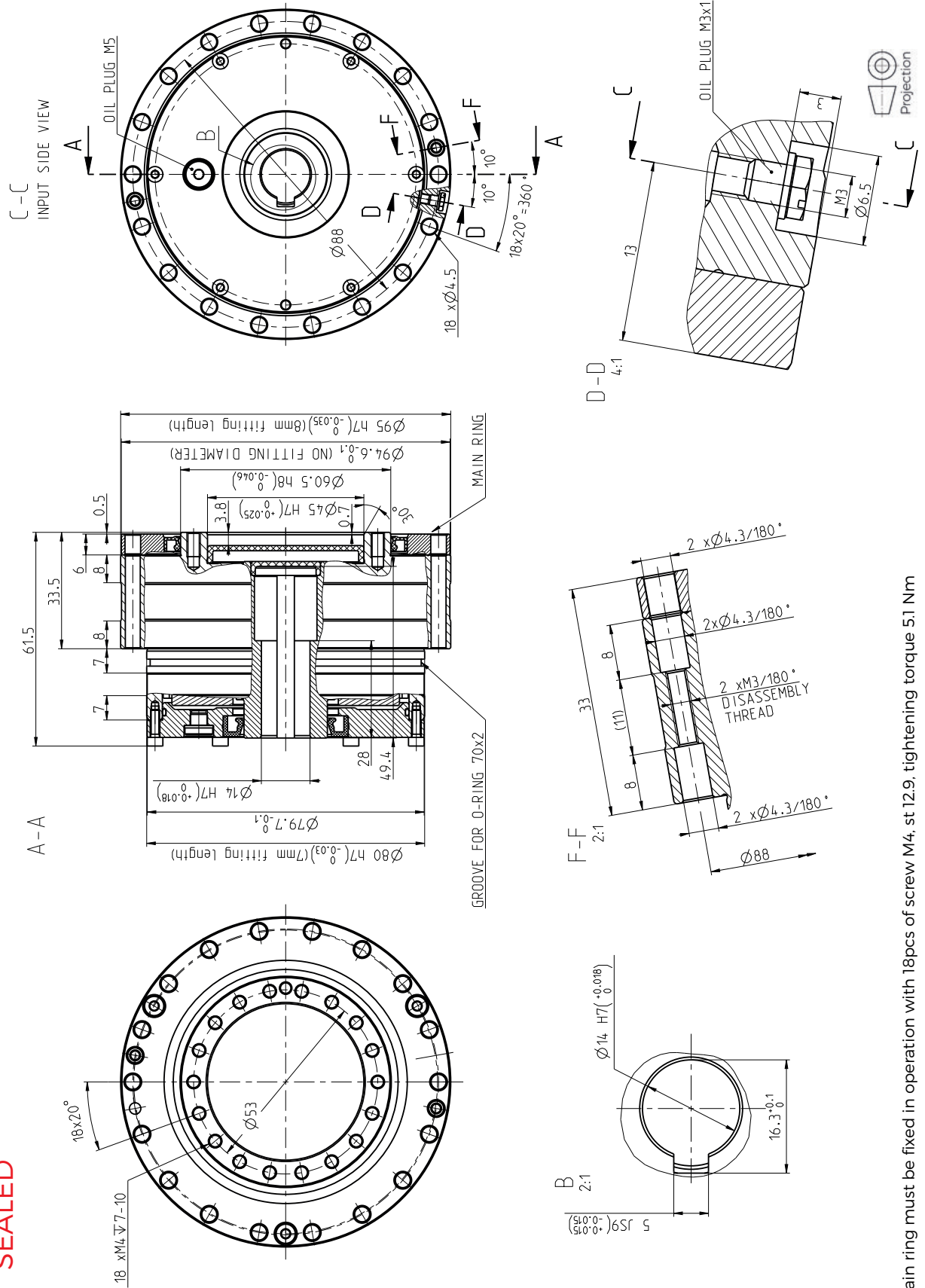
TS 85 - i - G - P11
SEALED



1. Main ring must be fixed in operation with 18pcs of screw M4, st 12.9, tightening torque 5.1 Nm

TS 95 - i - G - P14
SEALED

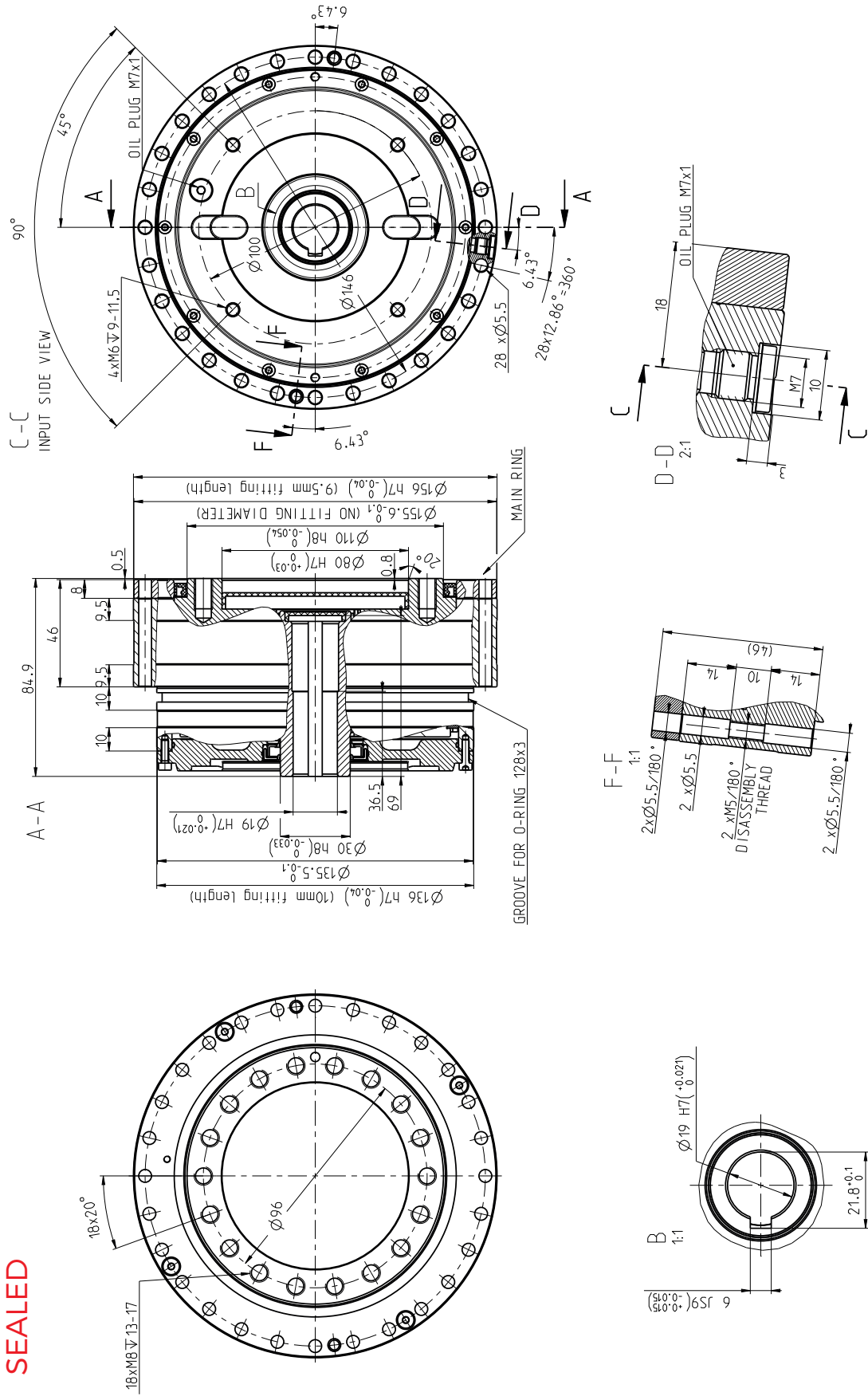
TS 95 - i - G - P14
SEALED



1. Main ring must be fixed in operation with 18pcs of screw M4, st 12.9, tightening torque 5.1 Nm

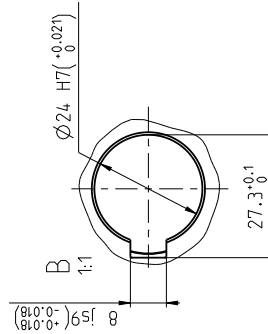
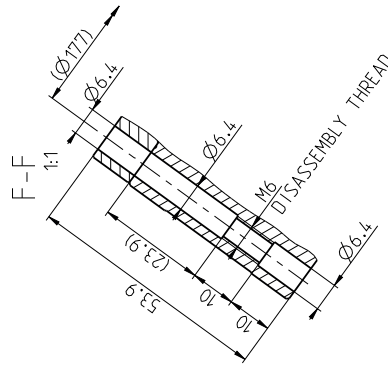
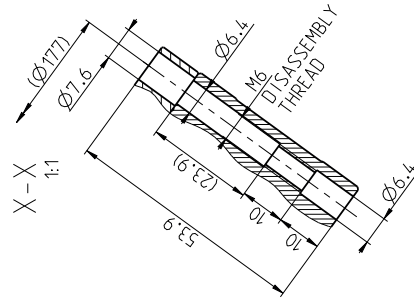
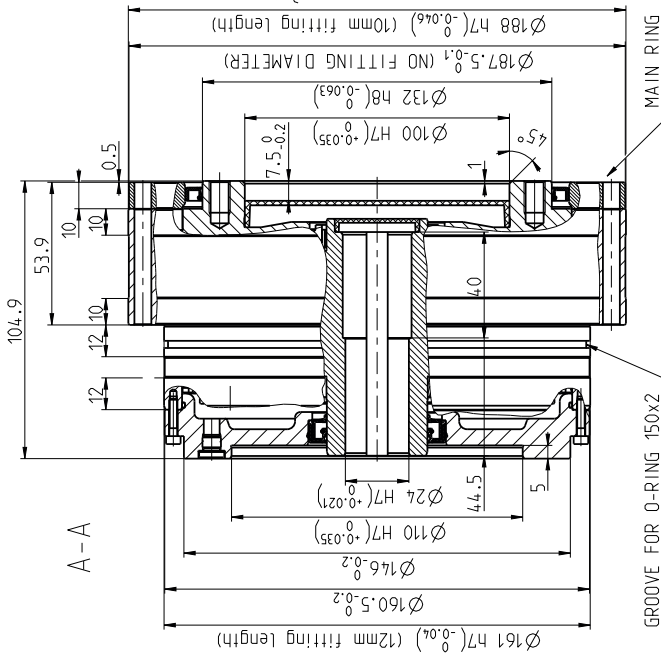
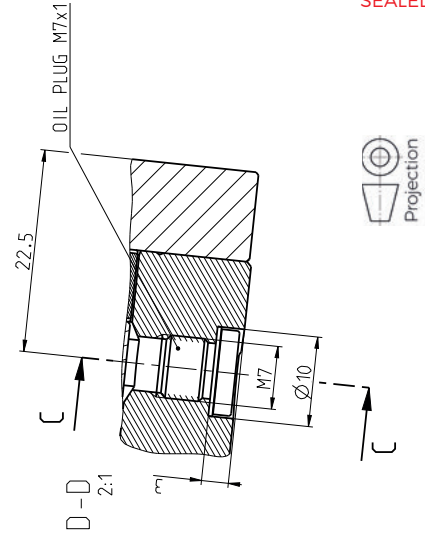
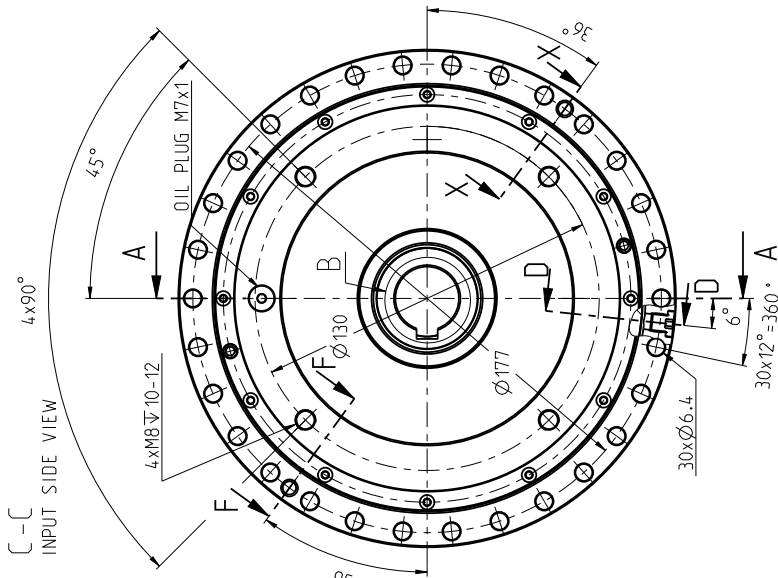
TS 155 - i - G - P19
SEALED

TS 155 - i - G - P19
SEALED

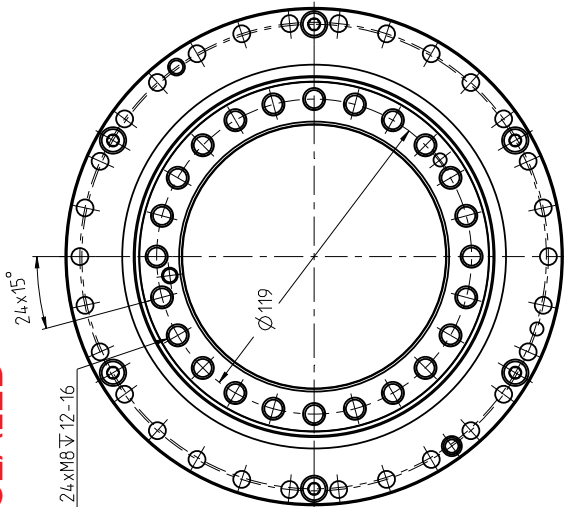


1. Main ring must be fixed in operation with 30pcs of screw M6, st 12.9, tightening torque 14 Nm

TS 185 - i - G - P24
SEALED



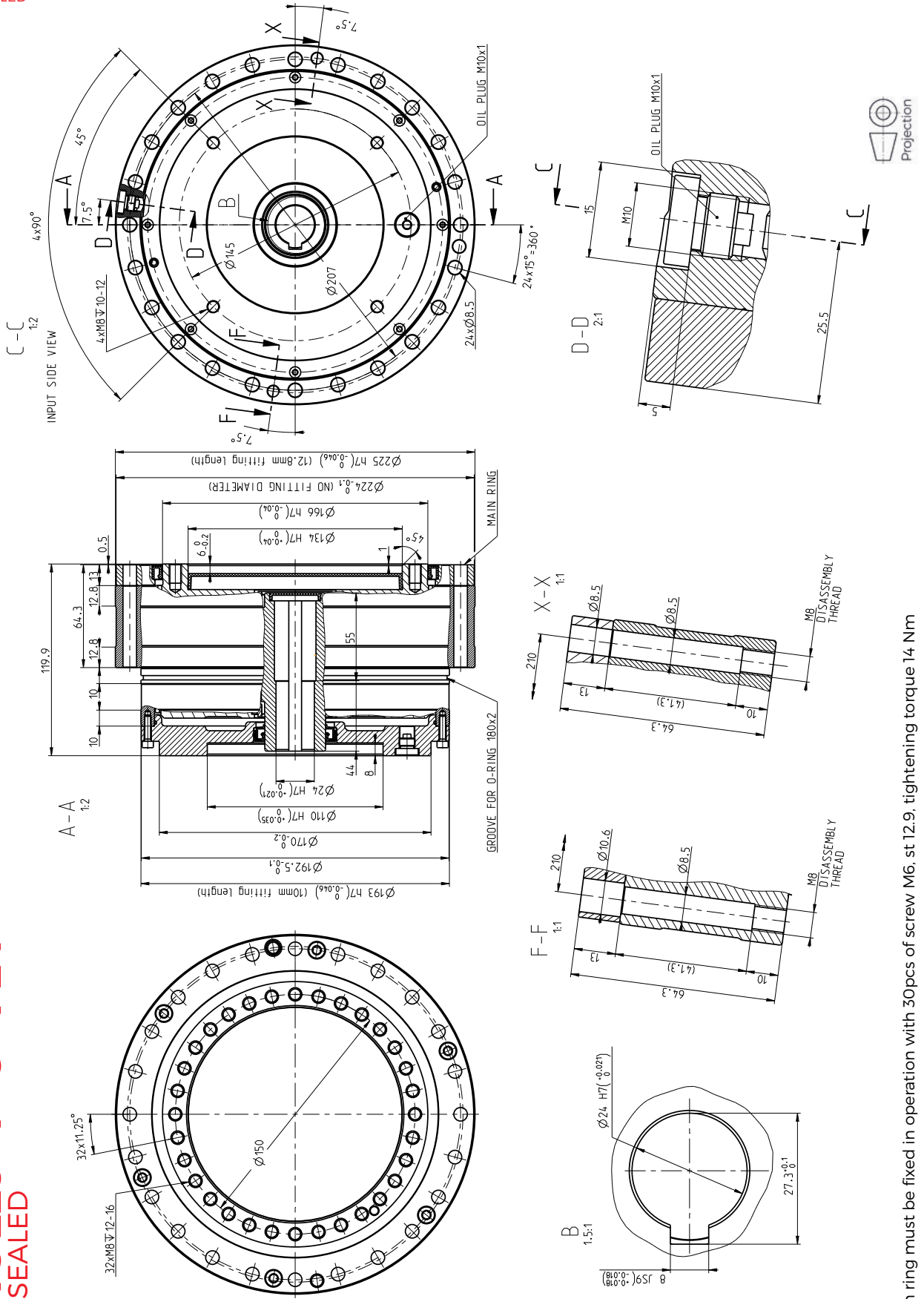
TS 185 - i - G - P24
SEALED



1. Main ring must be fixed in operation with 24 pcs of screw M8, st 12.9, tightening torque 35 Nm

TS 225 - i - G - P24
SEALED

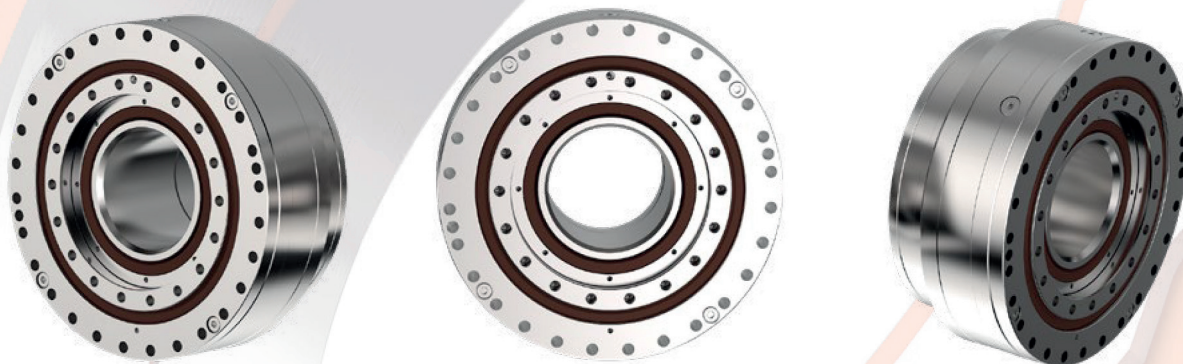
TS 225 - i - G - P24
SEALED



1. Main ring must be fixed in operation with 30pcs of screw M6. st 12.9. tightening torque 14 Nm



2.2 GH SERIES



Tab. 2.2a: GH series rating table

| Size | Reduction ratio | Shaft inside diameter | Rated output torque | Max. acceleration / deceleration torque | Maximum permissible torque at emergency / E-stop | Rated input speed | Maximum input speed 9) | Lost motion | Hysteresis | Angular transmission error 6) | No-load starting torque (max. 8) |
|---------------|-----------------|-----------------------|---------------------|---|--|-------------------|------------------------|-------------|------------|-------------------------------|----------------------------------|
| | i | d | T_R [Nm] | T_{acc} [Nm] | T_{em} [Nm] | n_r [rpm] | n_{max} [rpm] | LM [arcmin] | H [arcmin] | ATE [arcsec] | [Nm] |
| TS 85 | 47 | 21 | 41 | 82 | 205 | 2 000 | 3 800 | <1 | <1 | 72 | 0.6 |
| | 85 | | | | | | 4 500 | | | | 0.4 |
| TS 115 | 55 | 35 | 130 | 260 | 650 | 2 000 | 2 500 | <1 | <1 | 60 | 0.6 |
| | 123 | | | | | | 3 500 | | | | 0.5 |
| TS 125 | 49 | 32 | 180 | 450 | 900 | 2 000 | 2 400 | <1 | <1 | 60 | 1.5 |
| | 99 | | | | | | 3 800 | | | | 1.3 |
| TS 155 | 53 | 55 | 260 | 650 | 1 300 | 2 000 | 2 600 | <1 | <1 | 30 | 1.4 |
| | 109 | | | | | | 3 200 | | | | 1 |

RIGHT TO CHANGE WITHOUT PRIOR NOTICE RESERVED

- 1) Mean statistical value. For further information see chapter Torsional stiffness, Tilting stiffness.
- 2) Load at output speed 15 rpm and $L_{10} = 12\ 000$ hrs.
- 3) Moment M_c value for $F_a = 0$. If $F_a \neq 0$, see chapter 3.5.
- 4) Axial force $F_{a,max}$ value for $M_c = 0$. If $M_c \neq 0$ see chapter 3.5.
- 5) The parameter depends on the version of the high precision reduction gear.
- 6) The parameter depends on the version of the high precision reduction gear, ratio and lost motion.
- 7) The values of the parameters are informative. The exact value depends on the specific version of the high precision reduction gear.
- 8) Temperatures of the high precision reduction gear lower than 20°C will cause higher no-load starting or back driving torque.
- 9) Instantaneous speed peak that may occur within the working cycle.
- 10) For more information please contact the SPINEA sales department.

Tab. 2.2a: GH series rating table - continued

| Size | Reduction ratio | Max. backdriving torque 8) | Torsional stiffness 50-100% T _r 1) 6) | Moment stiffness 1) | Rated moment 2) 3) | Allowable moment | Allowable radial force 2) | Allowable axial force 2) 4) | Input inertia 7) | Weight 7) |
|---------------|-----------------|----------------------------|---|----------------------------|---------------------|------------------------|---------------------------|-----------------------------|--|-----------|
| | i | [Nm] | k _t [Nm/arcmin] | M _t [Nm/arcmin] | M _c [Nm] | M _{cmax} [Nm] | F _{rr} [kN] | F _{a,max} [kN] | I [10 ⁻⁴ kgm ²] | m [kg] |
| TS 85 | 47 | 25 | 9.5 | 85 | 110 | 115 | 2 | 6.4 | 0.29 | 1.3 |
| | 85 | 36 | 9.7 | | | | | | | |
| TS 115 | 55 | 42 | 21 | 200 | 275 | 550 | 4 | 12.5 | 0.65 | 2.9 |
| | 123 | 91 | 25 | | | | | | | |
| TS 125 | 49 | 40 | 28 | 280 | 440 | 445 | 5.7 | 17.7 | 1.06 | 3.6 |
| | 99 | 95 | 29 | | | | | | | |
| TS 155 | 53 | *10) | 67 | 900 | 820 | 1 640 | 8 | 26 | 5.6 | 6.9 |
| | | | 69 | | | | | | | |

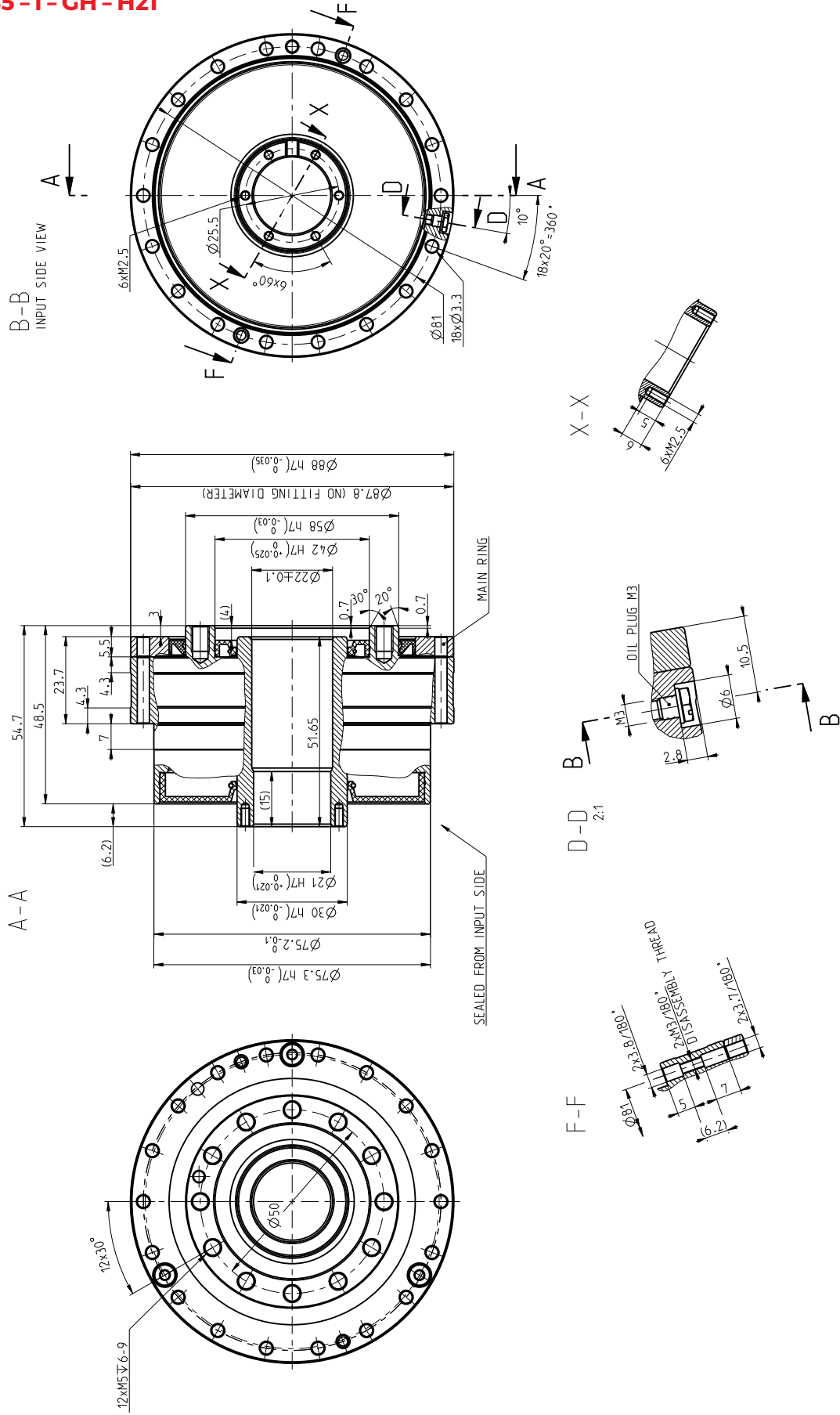
IMPORTANT NOTES:

- Load values in the table are valid for the nominal life of L₁₀ = 6 000 [Hrs].
- High precision reduction gears are preferred for intermittent cycles (S3-S8); the output speed in applications is inverted-variable.
- The continuous mode cycle (S1) is needed to be consulted with the manufacturer.
- If the output speed in application is less than 0.1 rpm please consult with the manufacturer.
- The values in the table refer to the nominal operating temperature.
- Please note the temperature on the gear case that should not exceed significantly 60°C degrees.

The ratios highlighted in bold are recommended by SPINEA as optimal versions in terms of price and delivery.

TS 85 - i - GH - H2I

TS 85 - i - GH - H2I

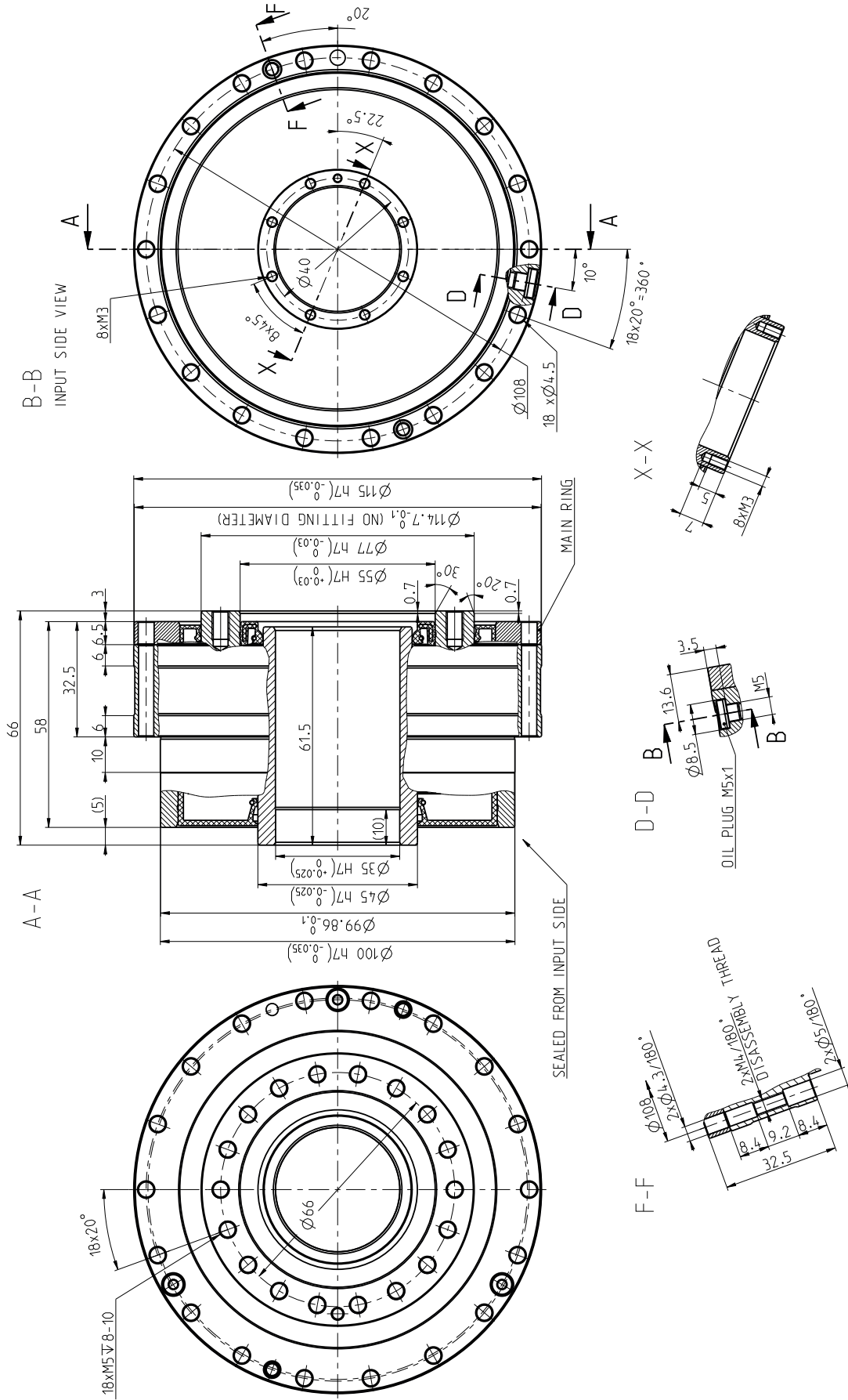


1. Main ring must be fixed in operation with 18pcs of screw M3, st 12.9, tightening torque 1.8 Nm

TS 115 - i - GH - H35



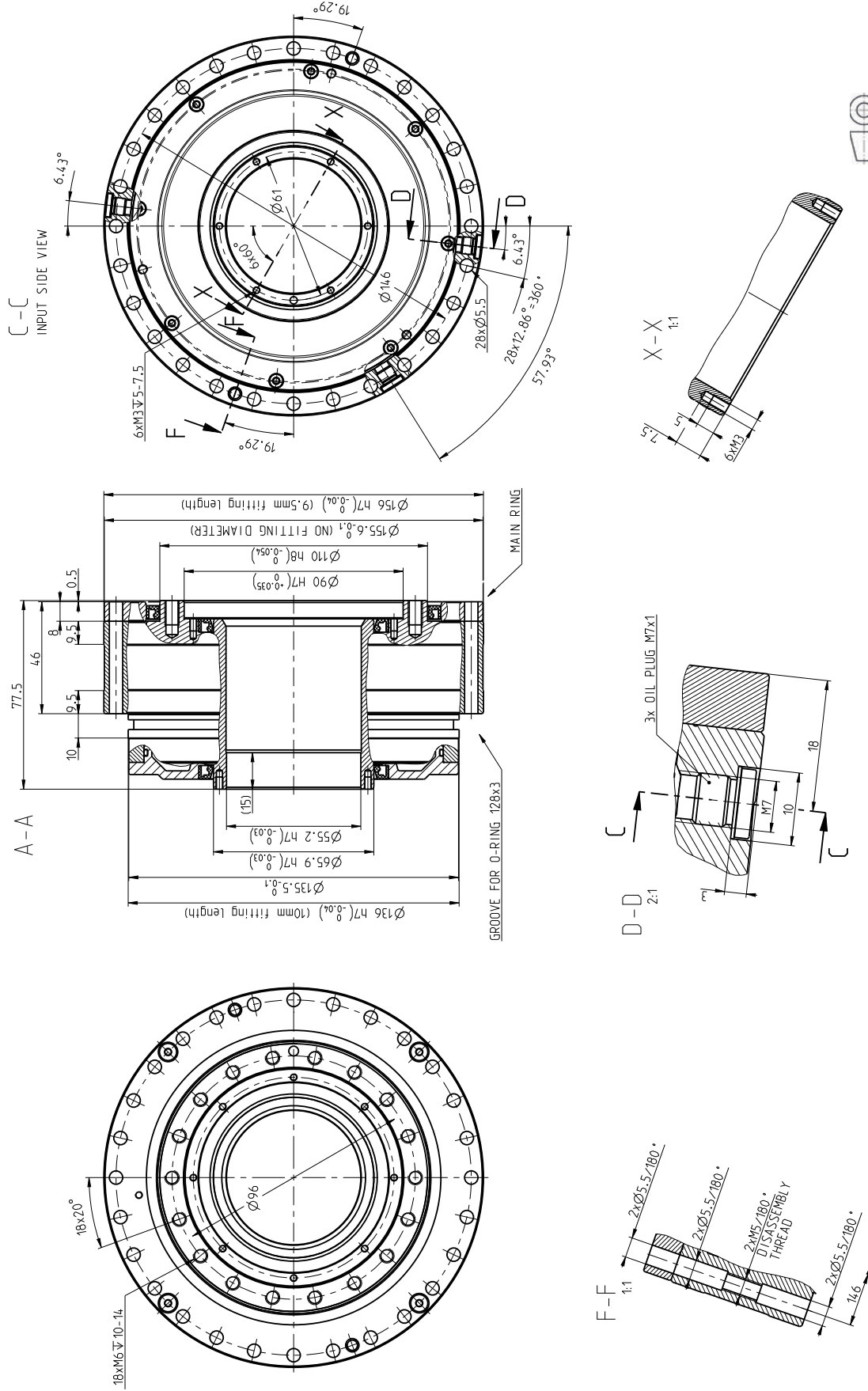
TS 115 - i - GH - H35



1. Main ring must be fixed in operation with 18pcs of screw M4, st 12.9, tightening torque 5.1 Nm

TS 155 - i - GH - H55

TS 155 - i - GH - H55



1. Main ring must be fixed in operation with 18pcs of screw M5, st 12.9, tightening torque 8 Nm

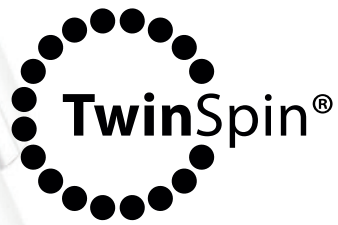


Zero-backlash reduction gear

Customisable input shaft

Integrated high capacity bearing

Compact design



T series

EXCELLENCE IN PERFORMANCE

2.3 T SERIES



Advantages

- zero- backlash reduction gear
- high moment capacity
- excellent positioning accuracy and positioning repeatability
- high torsional and tilting stiffness
- small dimensions and weight
- high reduction ratios
- long lifetime
- easy assembly

The **T series** represents a wide range of TwinSpin® high precision reduction gears with a cylindrical shaped case. The T series high precision reduction gears comprise an accurate reduction mechanism and a high-capacity radial and axial cylindrical roller bearings. This design of reduction gears allows the mounting of the load directly on the output flange or the case without the need of additional bearings. The T series high precision reduction gears are characterized by a modular design, which allows the mounting of your desirable type of motor to the reduction gear by means of a motor connection flange. The T series includes TwinSpin® high precision reduction gears that are not completely sealed; an inlet flange and a gasket kit have to be used for the sealing. Upon the customer's request, SPINEA is able to supply a completely sealed reduction gear with a flange according to the customer's motor.

Tab. 2.3a: T series features

| | |
|---|--|
| Case | a) TB- threaded holes in the case 1) b) TC- threaded and through holes in case 2 |
| Input flange connection | The shaft sealing / adapter flange is offered in the following versions: a) motor connection flange b) sealed input cover c) without a flange |
| Input shaft design | The input shaft is offered in the following versions: a) shaft with a keyway b) according to a special request |
| Installation and operation characteristics | A wider range of modular configurations |

1) Valid for TS 60, TS 70, TS 80, TS 110, TS 140

2) Valid for TS 170, TS 200, TS 240, TS 300

Tab. 2.3b: T series ordering specifications

T series

| TS - 200 - 125 - TC - P24 | | | | | |
|---------------------------|------|--------------------------------------|----------------|----------------------------|-----------------|
| Name | Size | Ratio | Series version | Shaft version | |
| | | | | P (DIN 6885) ¹⁾ | S ²⁾ |
| TS | 60 | 35, 47 , 63 | TB | 6 | • |
| | 70 | 41, 57, 75 | TB | 11 | • |
| | 80 | 37, 63 , 85 | TB | 8 | • |
| | 110 | 33, 67, 89 , 119 | TB | 14 | • |
| | 140 | 33 , 57, 87, 115 , 139 | TB | 19 | • |
| | 170 | 33, 59 , 83, 105 , 141 | TC | 24 | • |
| | 200 | 63 , 83, 125 , 169 | TC | 28 | • |
| | 240 | 37, 87, 121, 153 | TC | 24 | • |
| | 300 | 63 , 125, 191 | TC | 28 | • |

Note: An example of an ordering code of a modified TwinSpin® T series reduction gear with a motor flange:
 TS200 - 125 - TC - P24 - M235 - P231. The markings M235 and P231 for a specific modification are defined by the manufacturer.
 1) Max. dimension
 2) On request

Shaft version


P

Shaft with a keyway


S

Special shaft

Tab. 2.3c: T series rating table

| Size | Reduction ratio | Rated output torque | Max. acceleration / deceleration torque | Permissible output torque at emergency stop | Rated input speed | Max. allowable input speed 9) | Tilting stiffness 1) 5) | Torsional stiffness 1) 6) | Max. no-load starting torque 8) | Max. back-driving torque 8) |
|---------------|-----------------|---------------------|---|---|-------------------|-------------------------------|-------------------------|---------------------------|---------------------------------|-----------------------------|
| | i | T_R [Nm] | T_{acc} [Nm] | T_{em} [Nm] | n_R [rpm] | n_{max} [rpm] | M_t [Nm/arcmin] | k_t [Nm/arcmin] | [Nm] | [Nm] |
| TS 60 | 35 | 37 | 74 | 185 | 2 000 | 4 000 | 27 | 3.5 | 0.16 | 9 |
| | 47 | | | | | 5 000 | | | 0.12 | 9 |
| | 63 | | | | | | | | 0.12 | 10 |
| TS 70 | 41 | 50 | 100 | 250 | 2 000 | 4 000 | 35 | 7 | 0.30 | 11 |
| | 57 | | | | | 5 000 | | | 0.15 | 12 |
| | 75 | | | | | | | | 0.14 | 13 |
| TS 80 | 37 | 78 | 156 | 390 | 2 000 | 4 000 | 62 | 9 | 0.35 | 14 |
| | 63 | | | | | 5 000 | | | 0.20 | 15 |
| | 85 | | | | | | | | 0.12 | 16 |
| TS 110 | 33 | 122 | 244 | 610 | 2 000 | 3 500 | 150 | 22 | 0.35 | 24 |
| | 67 | | | | | 3 900 | | | 0.35 | 28 |
| | 89 | | | | | 4 500 | | | 0.30 | 30 |
| | 119 | | | | | | | | 0.20 | 33 |
| TS 140 | 33 | 268 | 670 | 1 340 | 2 000 | 3 000 | 340 | 54 | 0.60 | 40 |
| | 57 | | | | | 3 200 | | | 0.40 | 40 |
| | 87 | | | | | 4 500 | | | 0.35 | 55 |
| | 115 | | | | | | | | 0.35 | 65 |
| TS 170 | 139 | 495 | 1 237 | 2 475 | 2 000 | | 705 | 102 | 0.34 | 65 |
| | 33 | | | | | 3 000 | | | 2.00 | 75 |
| | 59 | | | | | 3 500 | | | 2.00 | 85 |
| | 83 | | | | | 4 000 | | | 1.40 | 100 |
| | 105 | | | | | 4 000 | | | 1.20 | 125 |
| TS 200 | 141 | 890 | 2 225 | 4 450 | 2 000 | | 1 070 | 178 | 0.40 | 125 |
| | 63 | | | | | 3 500 | | | 1.90 | 90 |
| | 83 | | | | | 4 000 | | | 1.80 | 120 |
| | 125 | | | | | 4 000 | | | 1.70 | 200 |
| | 169 | | | | | 4 500 | | | 0.90 | 210 |
| TS 240 | 37 | 1 620 | 4 050 | 8 100 | 1 500 | 2 000 | 1 800 | 340 | 3.00 | 90 |
| | 87 | | | | | 3 000 | | | 1.75 | 160 |
| | 121 | | | | | 3 500 | | | 1.70 | 170 |
| | 153 | | | | | 3 700 | | | 1.20 | 180 |
| TS 300 | 63 | 2 940 | 7 350 | 14 700 | 1 500 | 2 500 | 3 500 | 680 | 3.00 | 200 |
| | 125 | | | | | 3 200 | | | 2.00 | 250 |
| | 191 | | | | | 3 500 | | | 1.50 | 300 |

RIGHT TO CHANGE WITHOUT PRIOR NOTICE RESERVED

- 1) Mean statistical value. For further information see chapter Torsional stiffness, Tilting stiffness.
- 2) Load at output speed 15 rpm.
- 3) Moment $M_{c,max}$ value for $F_a=0$. If $F_a \neq 0$, see chapter 3.5.
- 4) Axial force F_a max value for $M_c=0$. If $M_c \neq 0$, see chapter 3.5.
- 5) The parameter depends on the version of the high precision reduction gear.
- 6) The parameter depends on the version of the high precision reduction gear, ratio and lost motion.
- 7) The values of the parameters are informative. The exact value depends on the specific version of the high precision reduction gear.
- 8) Temperatures of the high precision reduction gear lower than 20°C will cause higher no-load starting or back driving torque.
- 9) Instantaneous speed peak that may occur within the working cycle.

Tab. 2.3c: T series rating table - continued

| Size | Reduction ratio | Max. lost motion | Average angular transmission error 1) 6) | Hysteresis | Max. moment 2) 3) | Rated radial force 2) | Max. axial force 2) 4) | Input inertia 7) | Weight 7) |
|---------------|-----------------|------------------|--|------------|-------------------|-----------------------|------------------------|------------------------------------|-----------|
| | i | LM [arcmin] | ATE [arcsec] | H [arcmin] | $M_{c\max}$ [Nm] | F_{rR} [kN] | $F_{a\max}$ [kN] | I [10^{-4} kgm ²] | m [kg] |
| TS 60 | 35 | <1.5 | ±36 | <1.5 | 107 | 2.6 | 3.7 | 0.006 | 0.86 |
| | 47 | | | | | | | | |
| | 63 | | | | | | | | |
| TS 70 | 41 | <1.5 | ±36 | <1.5 | 142 | 2.8 | 4.1 | 0.061 | 1.05 |
| | 57 | | | | | | | | |
| | 75 | | | | | | | | |
| TS 80 | 37 | <1.5 | ±36 | <1.0 | 280 | 4.8 | 6.9 | 0.03 | 1.64 |
| | 63 | | | | | | | | |
| | 85 | | | | | | | | |
| TS 110 | 33 | <1.0 | ±20 | <1.0 | 740 | 9.3 | 13.1 | 0.16 | 3.76 |
| | 67 | | | | | | | | |
| | 89 | | | | | | | | |
| | 119 | | | | | | | | |
| TS 140 | 33 | <1.0 | ±20 | <1.0 | 1 160 | 11.5 | 17 | 0.67 | 6.45 |
| | 57 | | | | | | | | |
| | 87 | | | | | | | | |
| | 115 | | | | | | | | |
| TS 170 | 139 | <1.0 | ±20 | <1.0 | 2 430 | 19.2 | 27.9 | 1.15 | 11.07 |
| | 33 | | | | | | | | |
| | 59 | | | | | | | | |
| | 83 | | | | | | | | |
| TS 200 | 105 | <1.0 | ±18 | <1.0 | 3 300 | 21.1 | 31.7 | 2.6 | 17.23 |
| | 141 | | | | | | | | |
| | 63 | | | | | | | | |
| | 83 | | | | | | | | |
| TS 240 | 125 | <1.0 | ±18 | <1.0 | 5 720 | 30.8 | 47.3 | 3.9 | 31.15 |
| | 169 | | | | | | | | |
| | 37 | | | | | | | | |
| | 87 | | | | | | | | |
| TS 300 | 121 | <1.0 | ±18 | <1.0 | 12 000 | 45.3 | 68.1 | 11.2 | 55.73 |
| | 153 | | | | | | | | |
| | 63 | | | | | | | | |
| | 125 | | | | | | | | |
| | 191 | | | | | | | | |

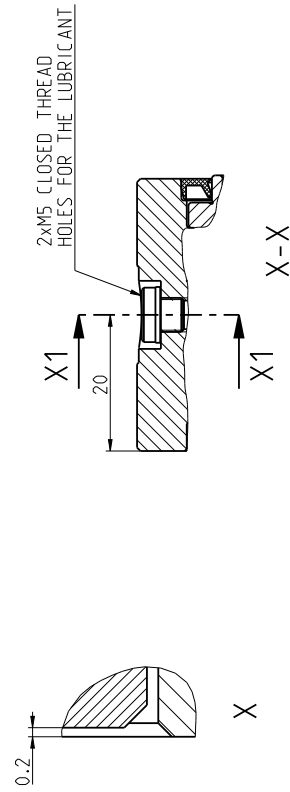
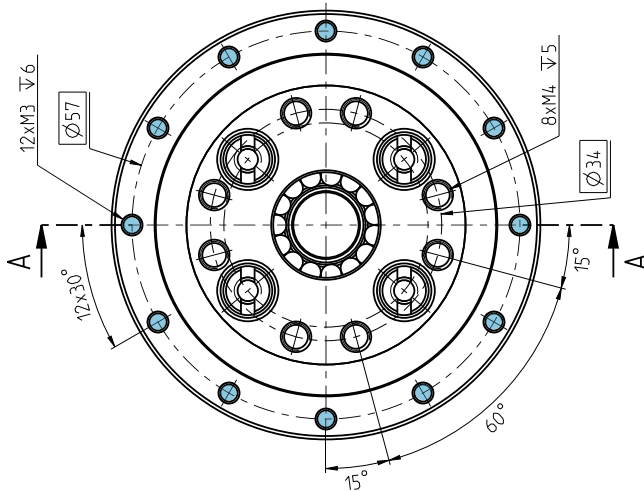
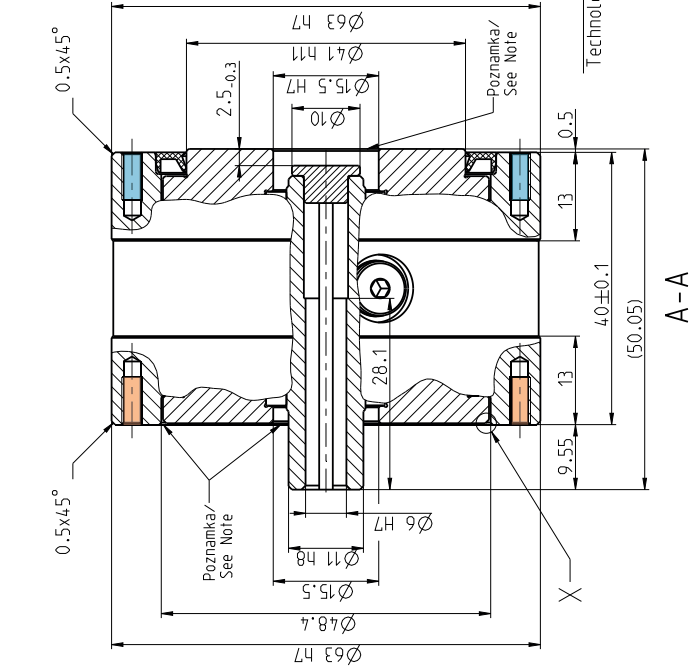
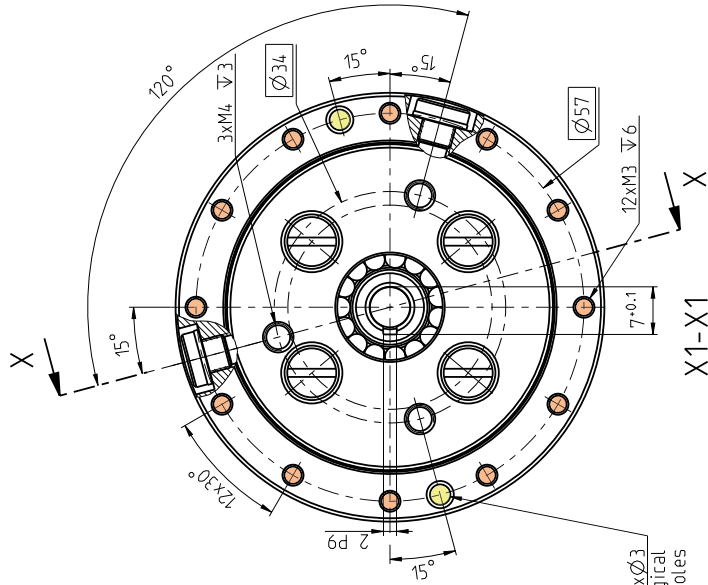
IMPORTANT NOTES:

- Instantaneous speed peak that may occur within the working cycle.
- Note please the temperature on the gear case that should not exceed significantly 60°C degrees.
- Load values in the table are valid for the nominal life of $L_{10} = 6\ 000$ [Hrs].
- High precision reduction gears are preferred for intermittent cycles (S3-S8); the output speed in applications is inverted-variable. The continuous mode cycle (S1) is needed to be consulted with the manufacturer.
- Dimensional pictures of the T series reduction gears are listed in the catalogue without sealing.
- Sealing options are described in the chapter Assembly instructions.
- Please consult the maximum speed in a duty cycle with the manufacturer.
- The values in the table refer to the nominal operating temperature.

The ratios highlighted in bold are recommended by SPINEA as optimal versions in terms of price and delivery.

TS 60 - i - TB - P6

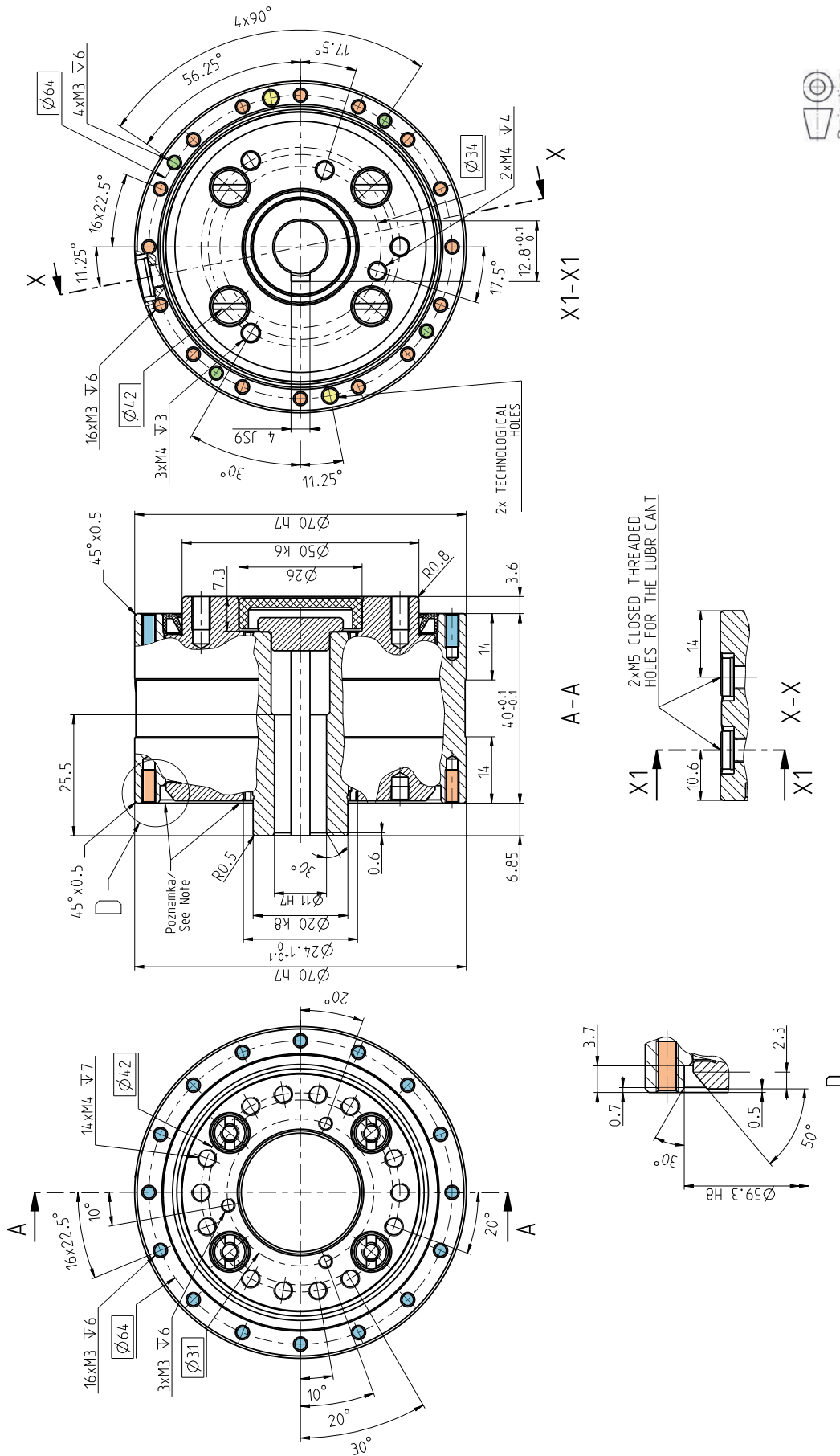
INPUT SIDE VIEW



1. Use only standardized components, such as ring seals, bolts, etc.
2. Right to change without prior notice reserved.
3. Unsealed space, see the installation instructions in the TS Catalogue.

TS 70 - i - TB - P11
TS 70 - i - TB - P11

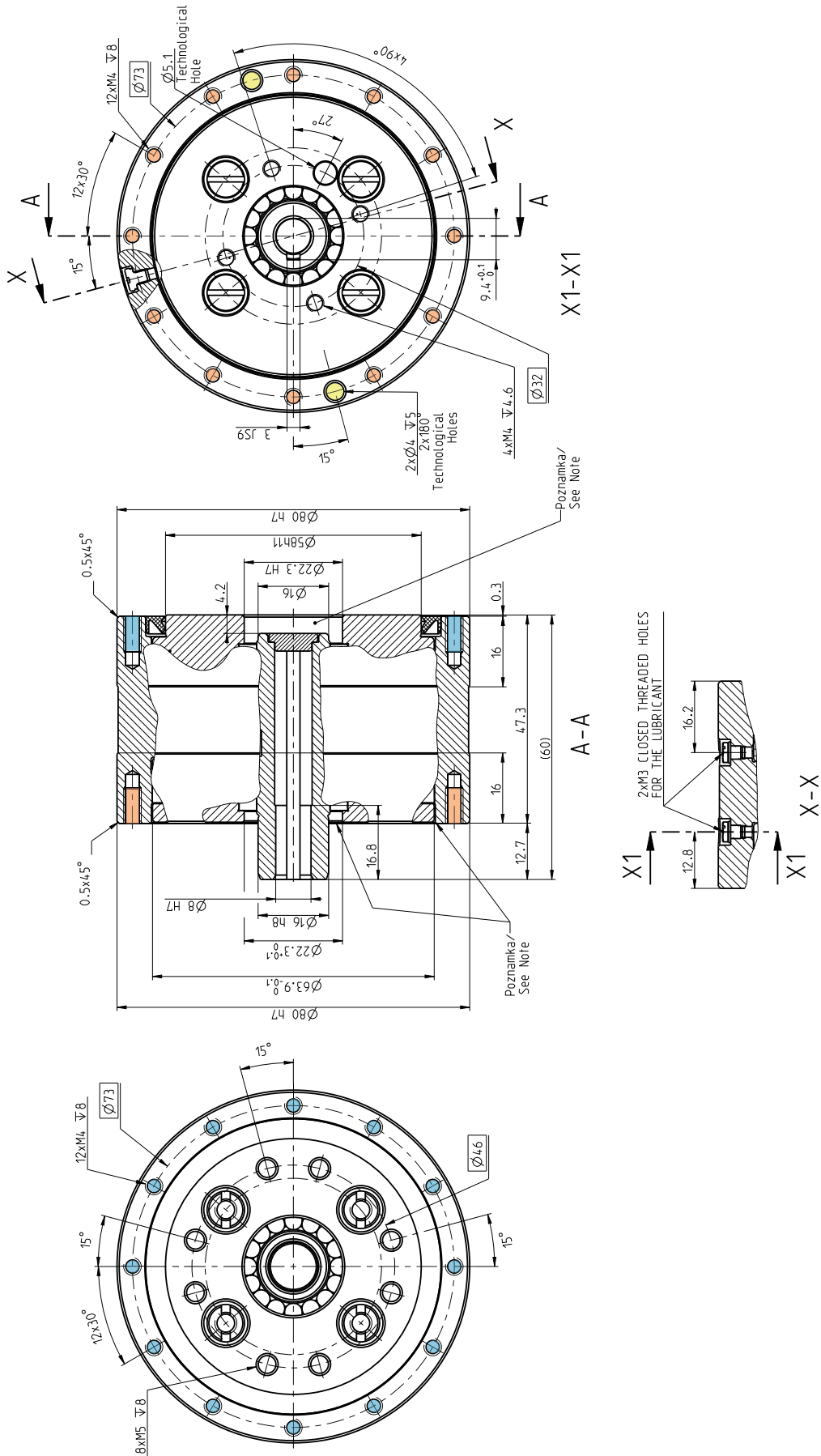
INPUT SIDE VIEW



1. Use only standardized components, such as ring seals, bolts, etc.
2. Right to change without prior notice reserved.
3. Unsealed space, see the installation instructions in the TS Catalogue.

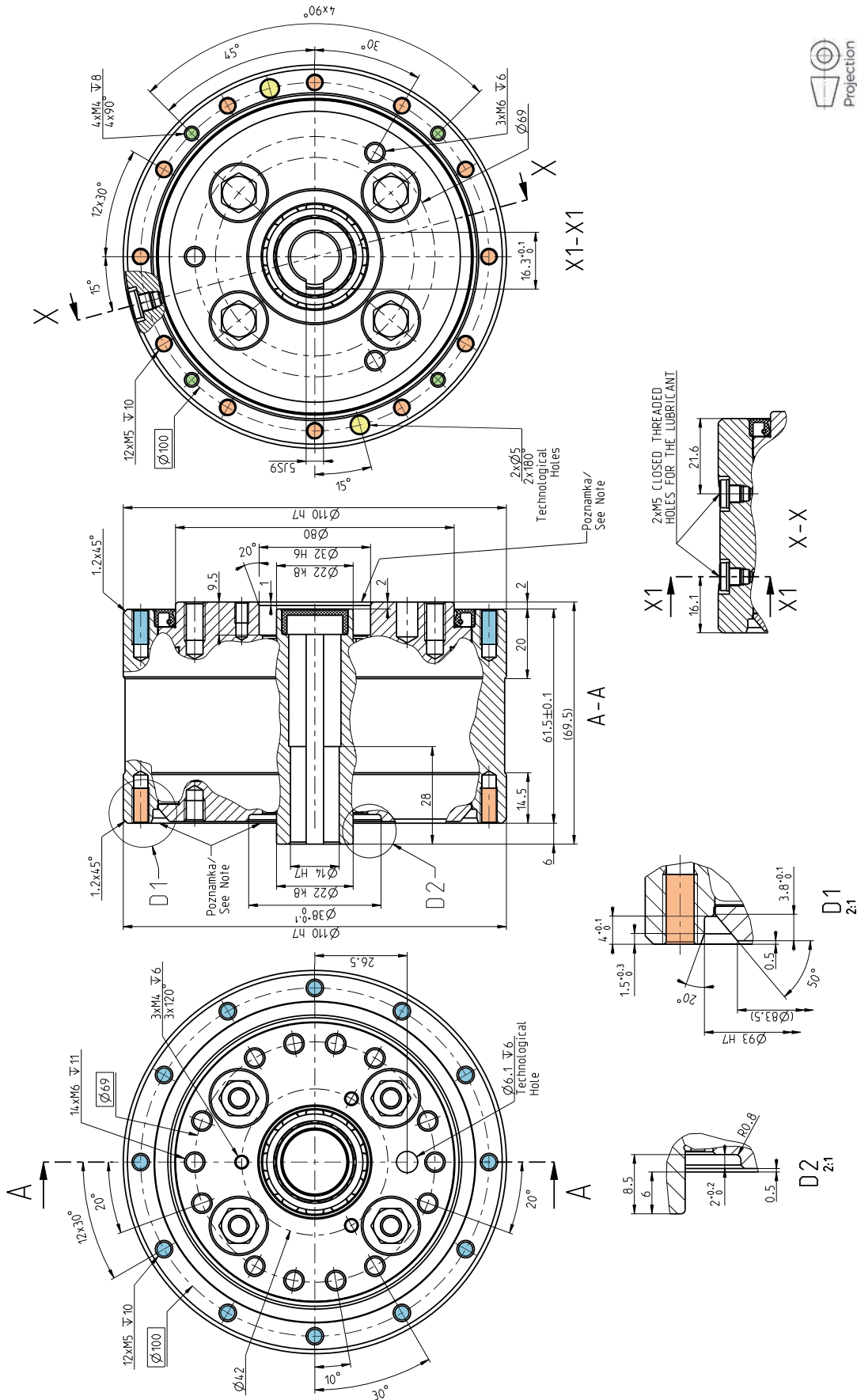
TS 80 - i - TB - P8

INPUT SIDE VIEW



1. Use only standardized components, such as ring seals, bolts, etc.
2. Right to change without prior notice reserved.
3. Unsealed space, see the installation instructions in the TS Catalogue.

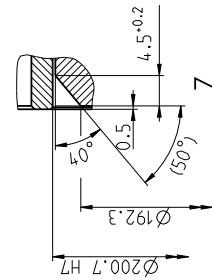
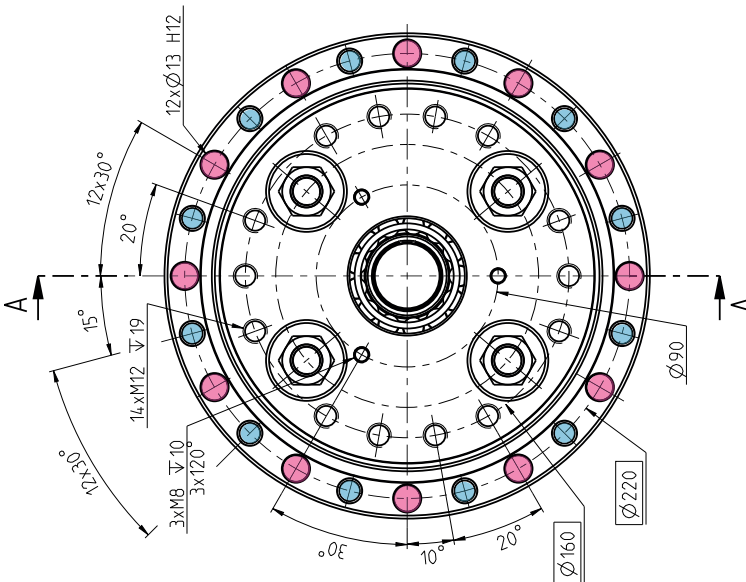
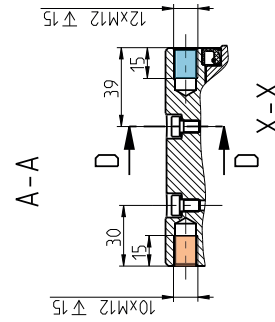
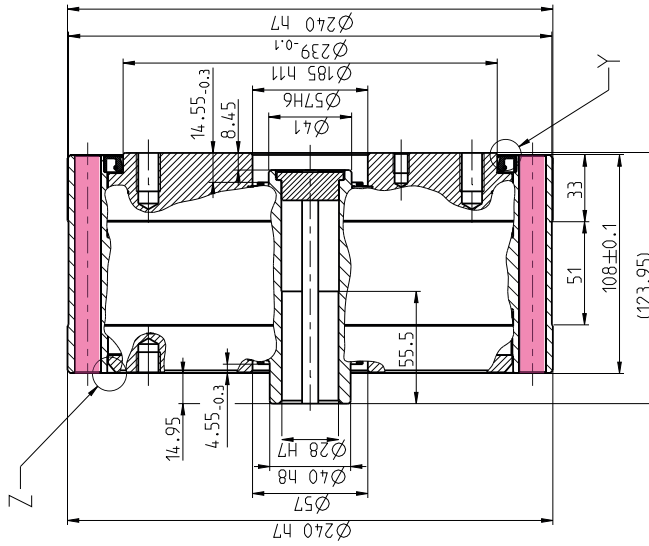
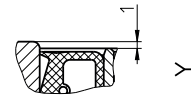
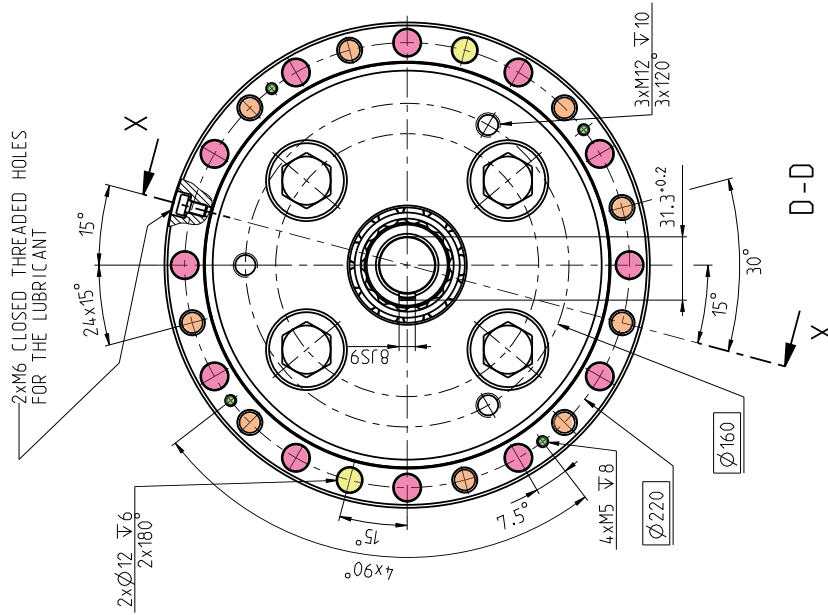
INPUT SIDE VIEW



T series

TS 240 - i - TC - P28

INPUT SIDE VIEW



1. Use only standardized components, such as ring seals, bolts, etc.
2. Right to change without prior notice reserved.
3. Unsealed space, see the installation instructions in the TS Catalogue.

T series



Robust design
and overload capacity

Zero-backlash reduction gear

Integrated high
capacity bearing

Customisable input shaft



E series

EXCELLENCE IN PRECISION

2.4 E SERIES



Advantages

- zero-backlash reduction gear
- high moment capacity
- excellent positioning accuracy and positioning repeatability
- high torsional and tilting stiffness
- small dimensions and weight
- high reduction ratios
- high efficiency
- long lifetime
- easy assembly

The **E series** represents a wide range of TwinSpin® high precision reduction gears with a flange shaped case. The E series high precision reduction gears comprise an accurate reduction mechanism and high-capacity radial and axial cylindrical bearings. This design of reduction gears allows the mounting of the load directly on the output flange or the case without the need of additional bearings. The E series high precision reduction gears are characterized by a modular design, which allows the mounting of your desirable type of motor to the reduction gear by means of a motor connection flange. The E series includes TwinSpin® high precision reduction gears that are not completely sealed; an inlet flange and a gasket kit have to be used for the sealing. Upon the customer's request, SPINEA is able to supply a completely sealed reduction gear with a flange according to the customer's motor.

Tab. 2.4a: E series features

| | |
|---|--|
| Case | Threaded and through holes in the case |
| Input flange connection | The shaft sealing / adapter flange is offered in the following versions: a) motor connection flange b) sealed input cover c) without a flange |
| Input shaft design | The input shaft is offered in the following versions: a) shaft with a keyway b) according to a special request |
| Installation and operation characteristics | Special for robotic and general automation |

Tab. 2.4b: E series ordering specifications

TS - 200 - 125 - E - P24

| Name | Size | Ratio | Series version | Shaft version | |
|-----------|------|-------------------------|----------------|---------------|---|
| | | | | P (DIN 6885) | S |
| TS | 70 | 41, 75 | E | 11 | • |
| | 80 | 37, 85 | E | 8 | • |
| | 110 | 33, 67, 119 | E | 14 | • |
| | 140 | 33, 69, 115 | E | 19 | • |
| | 170 | 33, 59, 125, 141 | E | 24 | • |
| | 200 | 49, 63, 125, 169 | E | 24 | • |
| | 220 | 55, 125 | E | 28 | • |

E series

Note: An example of an ordering code of a modified TwinSpin® T series reduction gear with a motor flange:
 TS200 - 125 - TC - P24 - M235 - P231. The markings M235 and P231 for a specific modification are defined by the manufacturer.

Shaft version


P

Shaft with a keyway


S

Special shaft

Tab. 2.4c: E series rating table

| Size | Reduction ratio | Rated output torque | Max. acceleration / deceleration torque | Permissible output torque at emergency stop | Rated input speed | Max. allowable input speed 9) | Tilting stiffness 1) 5) | Torsional stiffness 1) 6) | Max. no-load starting torque 8) | Max. back-driving torque 8) |
|---------------|-----------------|---------------------|---|---|----------------------|-------------------------------|----------------------------|----------------------------|---------------------------------|-----------------------------|
| | i | T _R [Nm] | T _{acc} [Nm] | T _{em} [Nm] | n _R [rpm] | n _{max} [rpm] | M _t [Nm/arcmin] | k _t [Nm/arcmin] | [Nm] | [Nm] |
| TS 70 | 41 | 50 | 100 | 250 | 2 000 | 4 000 | 40 | 8 | 0.30 | 11 |
| | 75 | | | | | 5 000 | | | 0.14 | 13 |
| TS 80 | 37 | 78 | 156 | 390 | 2 000 | 4 000 | 70 | 10 | 0.35 | 14 |
| | 85 | | | | | 5 000 | | | 0.12 | 16 |
| TS 110 | 33 | 122 | 244 | 610 | 2 000 | 3 500 | 115 | 24 | 0.35 | 24 |
| | 67 | | | | | 3 900 | | | 0.35 | 28 |
| | 119 | | | | | 4 500 | | | 0.20 | 33 |
| TS 140 | 33 | 268 | 670 | 1 340 | 2 000 | 3 000 | 380 | 62 | 0.60 | 40 |
| | 69 | | | | | 4 500 | | | 0.40 | 50 |
| | 115 | | | | | | | | 0.35 | 65 |
| TS 170 | 33 | 495 | 1 237 | 2 475 | 2 000 | 3 000 | 1 100 | 110 | 2.00 | 75 |
| | 59 | | | | | 3 500 | | | 2.00 | 85 |
| | 125 | | | | | 3 900 | | | 1.20 | 125 |
| | 141 | | | | | 4 000 | | | 0.40 | 125 |
| TS 200 | 49 | 890 | 2 225 | 4 450 | 2 000 | 2 500 | 1 300 | 200 | 2.10 | 80 |
| | 63 | | | | | 3 500 | | | 1.90 | 90 |
| | 125 | | | | | 4 000 | | | 1.70 | 200 |
| | 169 | | | | | 4 500 | | | 0.90 | 210 |
| TS 220 | 55 | 1 250 | 3 125 | 6 250 | 2 000 | 2 400 | 1 900 | 310 | 1.80 | 75 |
| | 125 | | | | | 3 500 | | | 1.40 | 220 |

RIGHT TO CHANGE WITHOUT PRIOR NOTICE RESERVED

- 1) Mean statistical value. For further information see chapter Torsional stiffness, Tilting stiffness.
- 2) Load at output speed 15 rpm.
- 3) Moment $M_{c_{max}}$ value for $F_a=0$. If $F_a \neq 0$, see chapter 3.5.
- 4) Axial force F_a max value for $M_c=0$. If $M_c \neq 0$, see chapter 3.5.
- 5) The parameter depends on the version of the high precision reduction gear.
- 6) The parameter depends on the version of the high precision reduction gear, ratio and lost motion.
- 7) The values of the parameters are informative. The exact value depends on the specific version of the high precision reduction gear.
- 8) Temperatures of the high precision reduction gear lower than 20°C will cause higher no-load starting or back driving torque.
- 9) Instantaneous speed peak that may occur within the working cycle.

Tab. 2.4c: E series rating table - continued

| Size | Reduction ratio | Max. lost motion | Average angular transmission error 1) 6) | Hysteresis | Max. moment 2) 3) | Rated radial force 2) | Max. axial force 2) 4) | Input inertia 7) | Weight 7) |
|---------------|-----------------|------------------|--|------------|-------------------|-----------------------|------------------------|--|-----------|
| | i | LM [arcmin] | ATE [arcsec] | H [arcmin] | $M_{c\ max}$ [Nm] | F_{r} [kN] | $F_{a\ max}$ [kN] | I [10 ⁻⁴ kgm ²] | m [kg] |
| TS 70 | 41 | <1.5 | ±30 | <1.5 | 142 | 2.8 | 4.1 | 0.061 | 1 |
| | 75 | | | | | | | | |
| TS 80 | 37 | <1.5 | ±30 | <1.0 | 280 | 4.8 | 6.9 | 0.03 | 1.6 |
| | 85 | | | | | | | | |
| TS 110 | 67 | <1.0 | ±17 | <1.0 | 740 | 9.3 | 13.1 | 0.16 | 3.7 |
| | 119 | | | | | | | | |
| TS 140 | 69 | <1.0 | ±17 | <1.0 | 1 160 | 11.5 | 17 | 0.67 | 5.8 |
| | 115 | | | | | | | | |
| TS 170 | 33 | <1.0 | ±17 | <1.0 | 2 430 | 19.2 | 27.9 | 1.15 | 10.8 |
| | 59 | | | | | | | | |
| | 125 | | | | | | | | |
| TS 200 | 49 | <1.0 | ±15 | <1.0 | 3 300 | 21.1 | 31.7 | 2.6 | 17.2 |
| | 63 | | | | | | | | |
| | 125 | | | | | | | | |
| TS 220 | 55 | <1.0 | ±15 | <1.0 | 4 400 | 22.5 | 35.5 | 4.8 | 22.4 |
| | 125 | | | | | | | | |

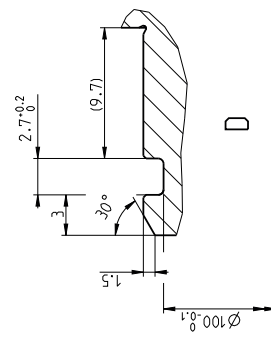
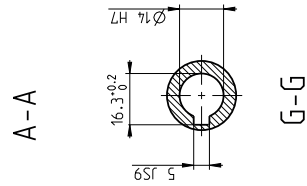
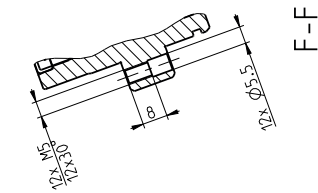
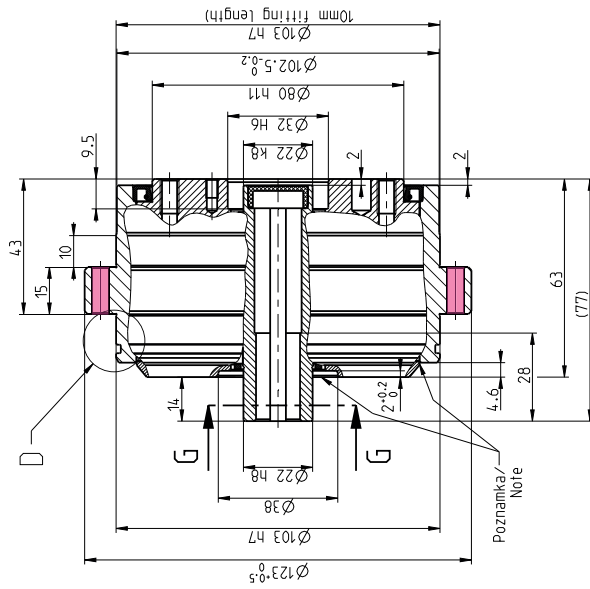
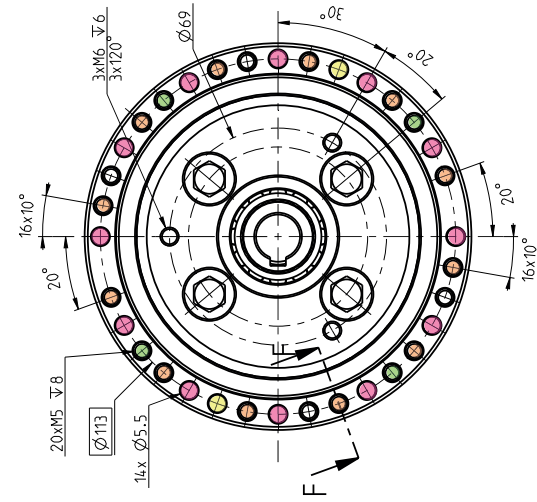
IMPORTANT NOTES:

- Instantaneous speed peak that may occur within the working cycle.
- Note please the temperature on the gear case that should not exceed significantly 60°C degrees.
- Load values in the table are valid for the nominal life of $L_{10} = 6\ 000$ [Hrs].
- High precision reduction gears are preferred for intermittent cycles (S3-S8): the output speed in applications is inverted-variable. The continuous mode cycle (S1) is needed to be consulted with the manufacturer.
- Dimensional pictures of the E series reduction gears are listed in the catalogue without sealing.
- Sealing options are described in the chapter Assembly instructions.
- Please consult the maximum speed in a duty cycle with the manufacturer.
- The values in the table refer to the nominal operating temperature.

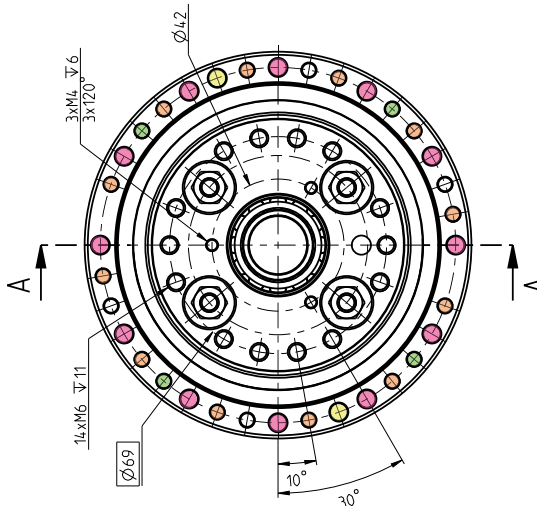
The ratios highlighted in bold are recommended by SPINEA as optimal versions in terms of price and delivery.

TS 110 - i - E - P 14

INPUT SIDE VIEW

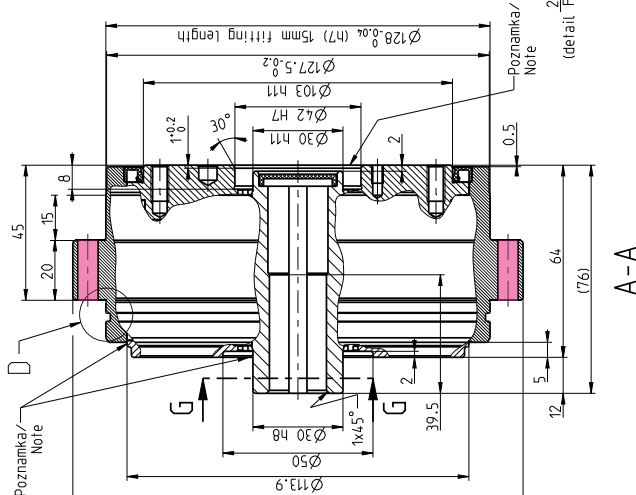
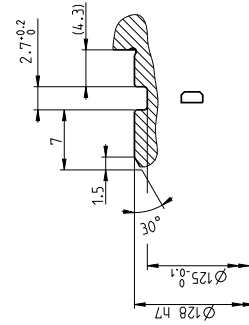
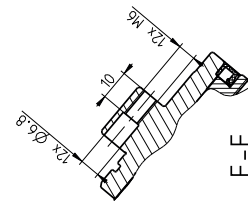
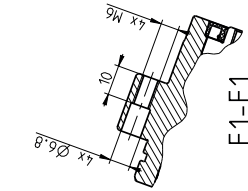
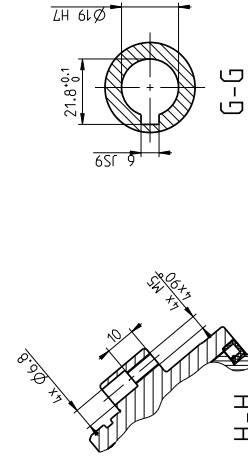
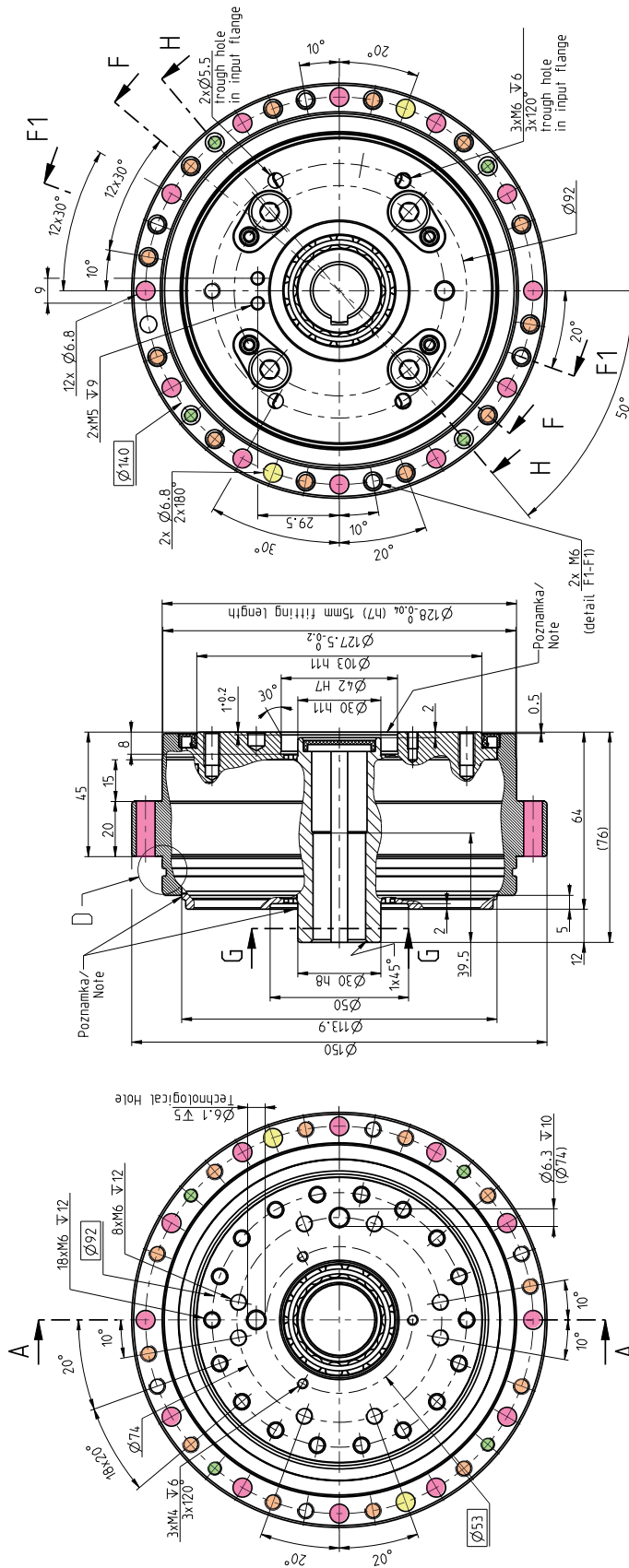


TS 110 - i - E - P 14



1. Use only standardized components, such as ring seals, bolts, etc.
2. Right to change without prior notice reserved.
3. Unsealed space, see the installation instructions in the TS Catalogue.

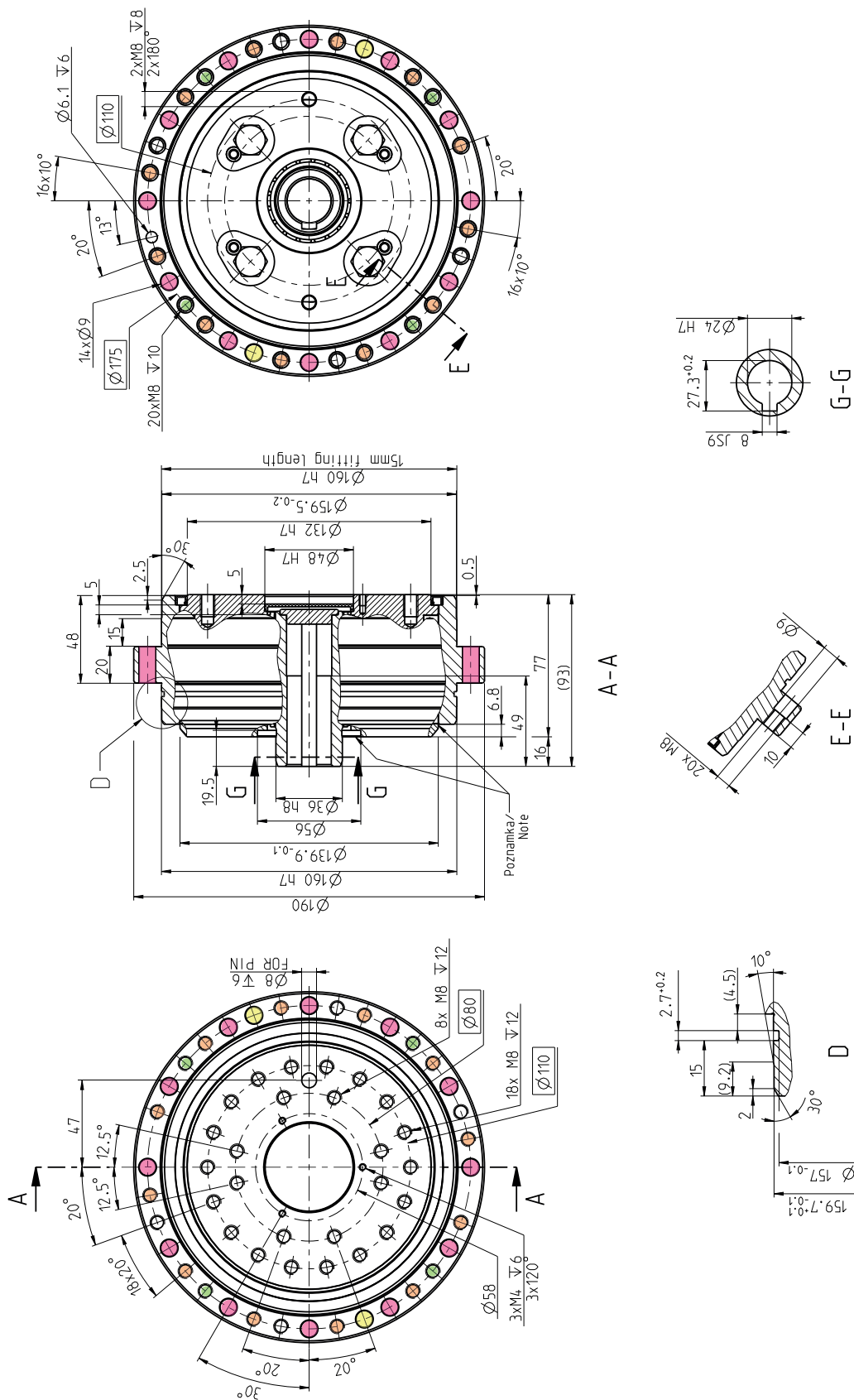
INPUT SIDE VIEW



1. Use only standardized components, such as ring seals, bolts, etc.
2. Right to change without prior notice reserved.
3. Unsealed space, see the installation instructions in the TS Catalogue.

TS 170-i-E-P 24

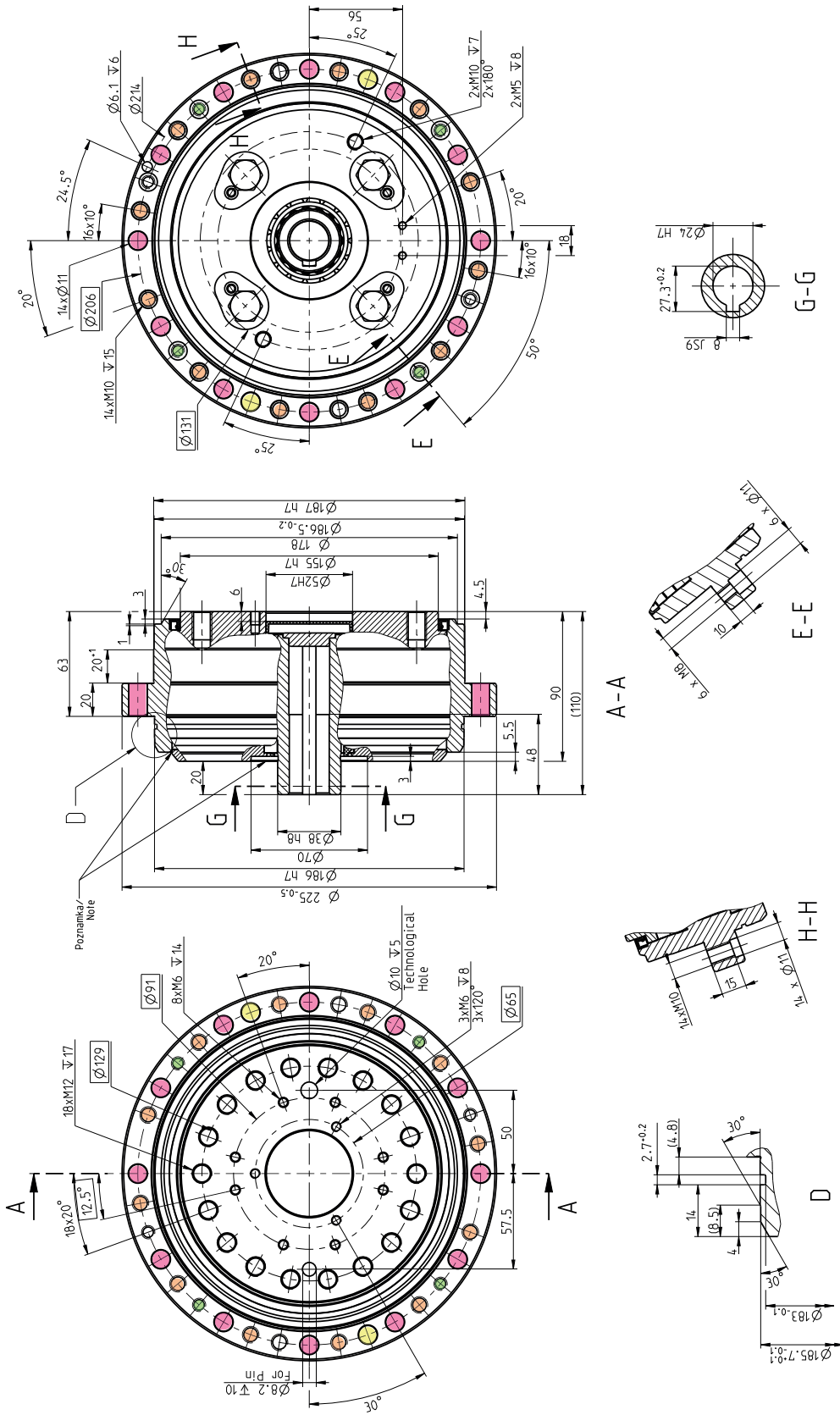
INPUT SIDE VIEW



TS 170-i-E-P 24

1. Use only standardized components, such as ring seals, bolts, etc.
2. Right to change without prior notice reserved.
3. Unsealed space, see the installation instructions in the TS Catalogue.

INPUT SIDE VIEW

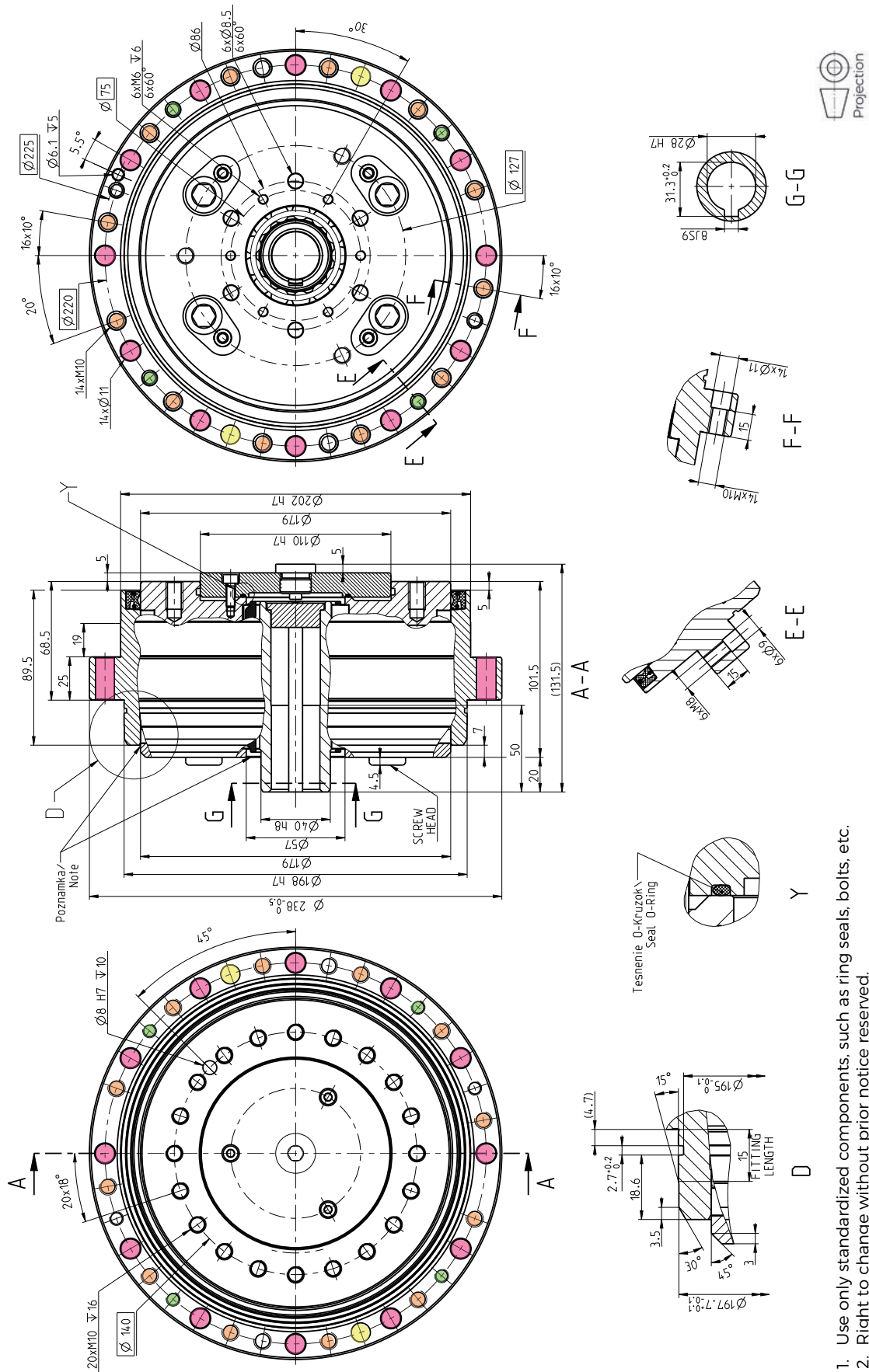


1. Use only standardized components, such as ring seals, bolts, etc.
2. Right to change without prior notice reserved.
3. Unsealed space, see the installation instructions in the TS Catalogue.

E series

TS 220 - i - E - P 28

INPUT SIDE VIEW



1. Use only standardized components, such as ring seals, bolts, etc.
2. Right to change without prior notice reserved.
3. Unsealed space, see the installation instructions in the TS Catalogue.



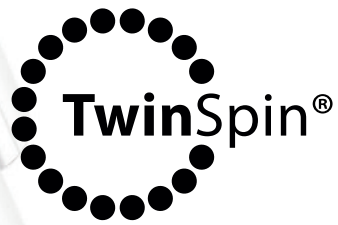


High overload capacity

Zero-backlash reduction gear

Integrated high capacity bearing

Fully sealed solution



H series

EXCELLENCE IN POSITIONING

2.5 H SERIES



Advantages

- large input shaft hole diameter
- fully sealed
- zero-backlash reduction gears
- high moment capacity
- excellent positioning accuracy and positioning repeatability
- high torsional and tilting stiffness
- small dimensions and weight
- high reduction ratios
- high efficiency
- long lifetime
- easy assembly

The **H series** represents TwinSpin® high-precision reduction gears with through-holes in the shafts, also known as the hollow-shaft version. Cables, tubes with compressed air, drive shafts etc. can be led through the hole in the shaft of the gear. The H series is completely sealed and filled with grease for lifetime. The H series high-precision reduction gears comprise an accurate reduction mechanism and high-capacity radial and axial cylindrical bearings. This design of the reduction gears allows the mounting of the load directly on the output flange or case without a need of additional bearings.

Tab. 2.5a: H series features

| | |
|---|--|
| Case | Threaded and through holes in the case |
| Input flange connection | Completely sealed reduction gear |
| Input shaft design* | The input shaft is offered in the following versions: a) hollow shaft b) according to a special request |
| Installation and operation characteristics | Hollow-shaft reduction gears. A large hole in the input shaft allows cables, tubes or an additional shaft to pass through the reduction gear. Suitable for applications where the rotation of the input shaft is achieved by using a tooth belt or a similar arrangement. |

*On request

Tab. 2.5b: H series ordering specifications

TS - 200 - 125 - H - H52

| Name | Size | Ratio | Series version | Shaft version | |
|-----------|------|----------------|----------------|---------------|-----------------|
| | | | | H | S ¹⁾ |
| TS | 70 | 75 | H | 13 | • |
| | 140 | 69, 115 | H | 36 | • |
| | 170 | 69, 125 | H | 42, 46 | • |
| | 200 | 63, 125 | H | 52, 56 | • |
| | 220 | 55, 125 | H | 62, 65 | • |

H series

Note: An example of an ordering code of a modified H series TwinSpin® reduction gear with a motor flange:
 TS200 - 125 - H - H56 - M235 - P231. The markings M235 and P231 for a specific modification are defined by the manufacturer.
 1) On request

Shaft version


H

Hollow shaft


S

Special shaft

Tab. 2.5c: H series rating table

| Size | Reduction ratio | Shaft inside diameter | Rated output torque | Max. acceleration / deceleration torque | Permissible output torque at emergency stop | Rated input speed | Max. allowable input speed 9) | Tilting stiffness 1) 5) | Torsional stiffness 1) 6) | Max. no-load starting torque 8) | Max. back driving torque 8) |
|---------------|-----------------|-----------------------|---------------------|---|---|----------------------|-------------------------------|----------------------------|----------------------------|---------------------------------|-----------------------------|
| | i | d | T _R [Nm] | T _{acc} [Nm] | T _{em} [Nm] | n _R [rpm] | n _{max} [rpm] | M _t [Nm/arcmin] | k _t [Nm/arcmin] | [Nm] | [Nm] |
| TS 70 | 75 | 13 | 50 | 100 | 250 | 2 000 | 5 500 | 35 | 7.5 | 0.22 | 13 |
| TS 140 | 69 | 36 | 200 | 500 | 1 000 | 2 000 | 3 500 | 340 | 55 | 1.6 | 110 |
| | 115 | | | | | | 4 500 | | | 1.5 | 130 |
| TS 170 | 69 | 42 | 420 | 1 050 | 2 100 | 2 000 | 3 200 | 1 100 | 110 | 2.5 | 180 |
| | | 46 | | 825 | 1 650 | | | | | 2.2 | 240 |
| | 125 | 42 | | 1 050 | 2 100 | | 3 700 | | | 2.5 | 180 |
| | | 46 | | 825 | 1 650 | | | | | 2.2 | 240 |
| TS 200 | 63 | 52 | 712 | 1 780 | 3 560 | 2 000 | 2 700 | 2 000 | 200 | 4 | 250 |
| | | 56 | | 1 100 | 2 200 | | 3 700 | | | 3 | 300 |
| | 125 | 52 | | 1 780 | 3 560 | | | | | 3 700 | 3 |
| | | 56 | | 1 100 | 2 200 | | 3 | | | | 300 |
| TS 220 | 55 | 62 | 1 100 | 2 750 | 5 500 | 2 000 | 2 400 | 2 400 | 290 | 5 | 170 |
| | | 65 | | 2 000 | 4 000 | | 3 400 | | | 3 | 350 |
| | 125 | 62 | | 2 750 | 5 500 | | | | | 3 400 | 3 |
| | | 65 | | 2 000 | 4 000 | | 3 | | | | 350 |

RIGHT TO CHANGE WITHOUT PRIOR NOTICE RESERVED

- 1) Mean statistical value. For further information see chapter Torsional stiffness, Tilting stiffness.
- 2) Load at output speed 15 rpm.
- 3) Moment $M_{c,max}$ value for $F_a=0$. If $F_a \neq 0$, see chapter 3.5.
- 4) Axial force F_a max value for $M_c=0$. If $M_c \neq 0$, see chapter 3.5.
- 5) The parameter depends on the version of the high precision reduction gear.
- 6) The parameter depends on the version of the high precision reduction gear, ratio and lost motion.
- 7) The values of the parameters are informative. The exact value depends on the specific version of the high precision reduction gear.
- 8) Temperatures of the high precision reduction gear lower than 20°C will cause higher no-load starting or back driving torque.
- 9) Instantaneous speed peak that may occur within the working cycle.

Tab. 2.5c: H series rating table - continued

| Size | Reduction ratio | Max. lost motion | Average angular transmission error 1) 6) | Hysteresis | Max. moment 2) 3) | Rated radial force 2) | Max. axial force 2) 4) | Input inertia 7) | Weight 7) |
|---------------|-----------------|------------------|--|------------|-------------------|-----------------------|------------------------|------------------------------------|---------------|
| | i | LM [arcmin] | ATE [arcsec] | H [arcmin] | $M_{c\ max}$ [Nm] | F_{r} [kN] | $F_{a\ max}$ [kN] | I [10^{-4} kgm ²] | m [kg] |
| TS 70 | 75 | <1.5 | ±30 | <1.5 | 142 | 2.8 | 4.1 | 0.061 | 1 |
| TS 140 | 69 | <1.5 | ±17 | <1.0 | 1 160 | 11.5 | 17 | 3.6 | 7.5 |
| | 115 | | | | | | | | |
| TS 170 | 69 | <1.0 | ±17 | <1.0 | 2 000 | 19.2 | 27.9 | 4.8 | 11.6 |
| | 125 | | | | | | | | |
| TS 200 | 69 | <1.0 | ±15 | <1.0 | 3 300 | 21.5 | 31.7 | 18.2 | 20 |
| | 125 | | | | | | | | |
| TS 220 | 55 | <1.0 | ±15 | <1.0 | 4 400 | 22.5 | 35.5 | 31 | 26 |
| | 125 | | | | | | | | |

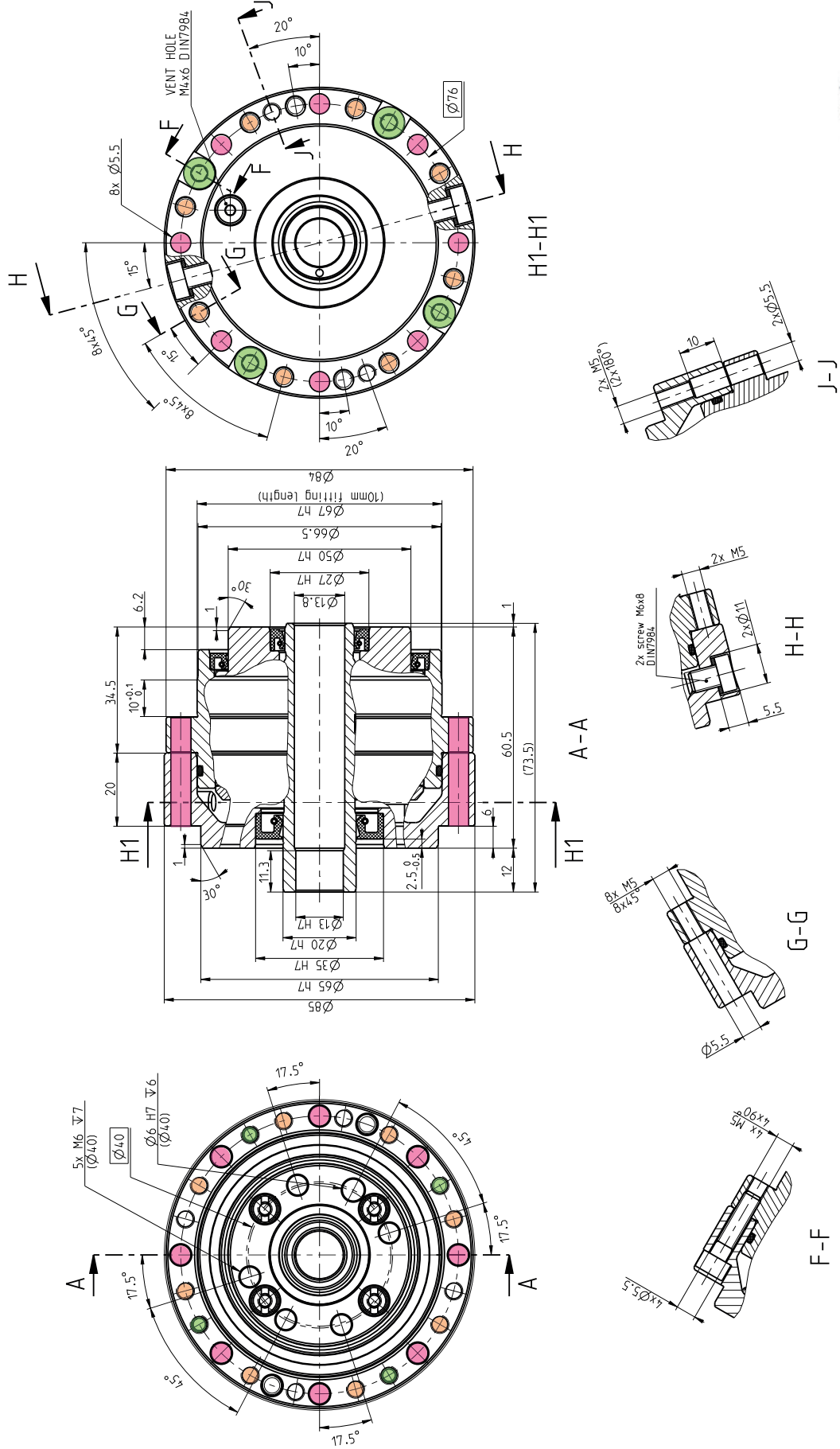
IMPORTANT NOTES:

- Instantaneous speed peak that may occur within the working cycle.
- Note please the temperature on the gear case that should not exceed significantly 60°C degrees.
- Load values in the table are valid for the nominal life of $L_{10} = 6\ 000$ [Hrs].
- High precision reduction gears are preferred for intermittent cycles (S3-S8): the output speed in applications is inverted-variable. The continuous mode cycle (S1) is needed to be consulted with the manufacturer.
- Please consult the maximum speed in a duty cycle with the manufacturer.
- The values in the table refer to the nominal operating temperature.

The ratios highlighted in bold are recommended by SPINEA as optimal versions in terms of price and delivery.

TS 70 - i - H - H13

INPUT SIDE VIEW

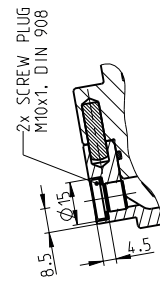
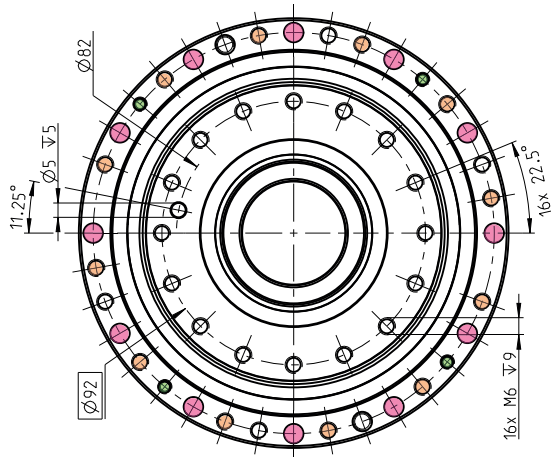
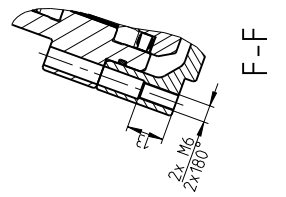
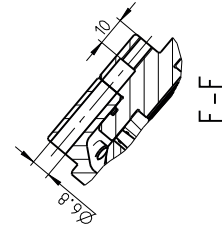
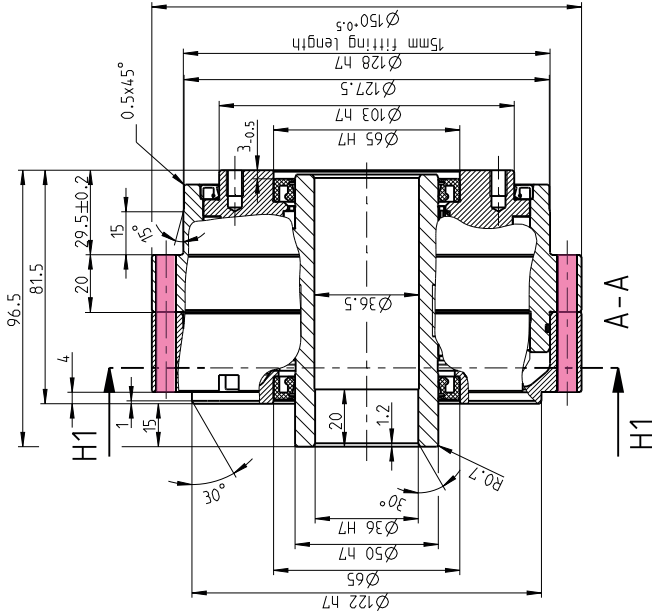
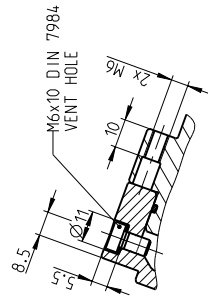
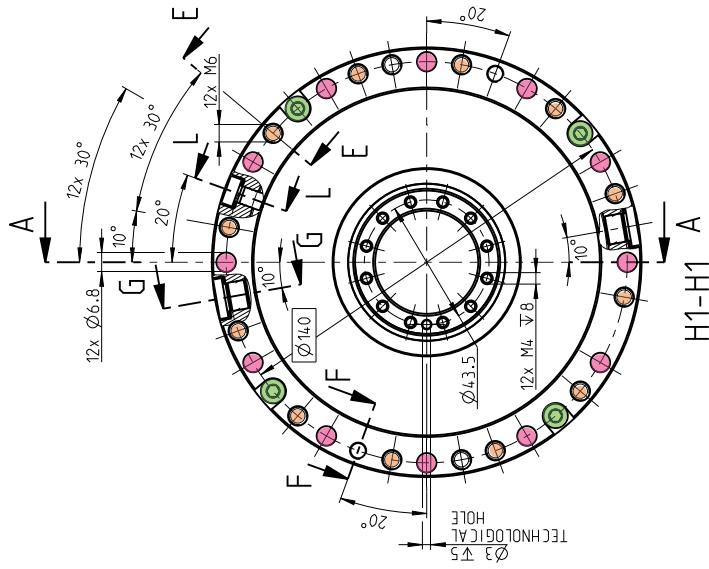


TS 70 - i - H - H13

1. Use only standardized components, such as ring seals, bolts, etc.
2. Right to change without prior notice reserved.

TS 140 - i - H - H 36

INPUT SIDE VIEW



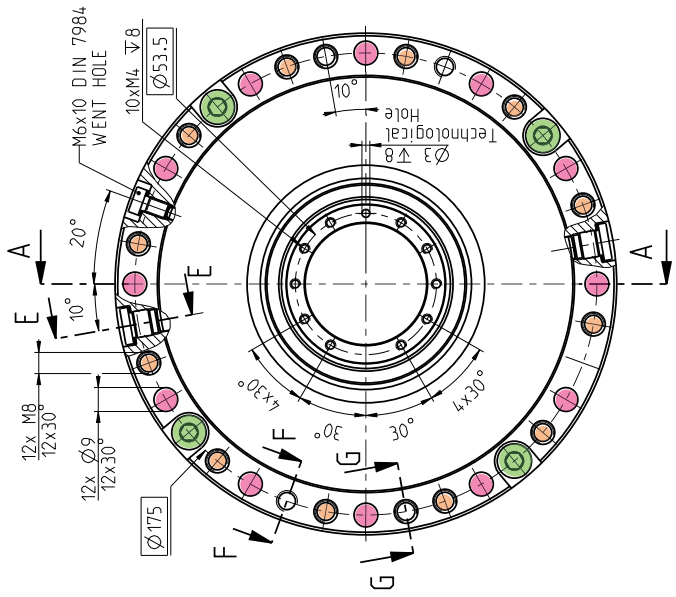
TS 140 - i - H - H 36

1. Use only standardized components, such as ring seals, bolts, etc.
2. Right to change without prior notice reserved.

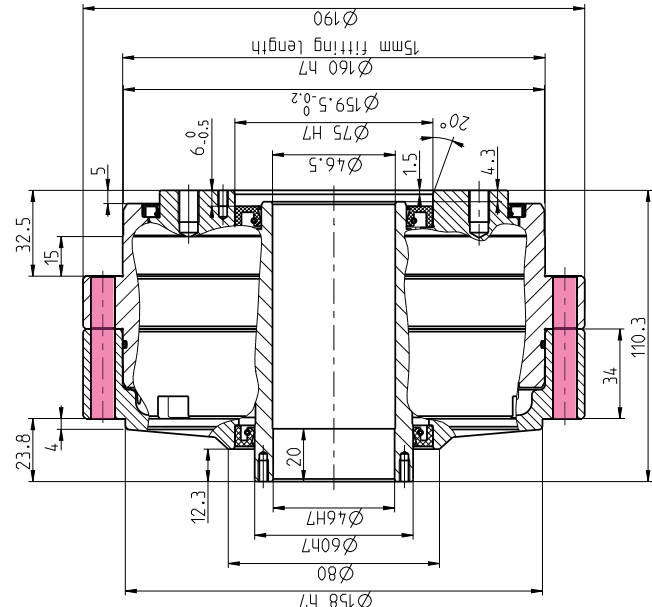
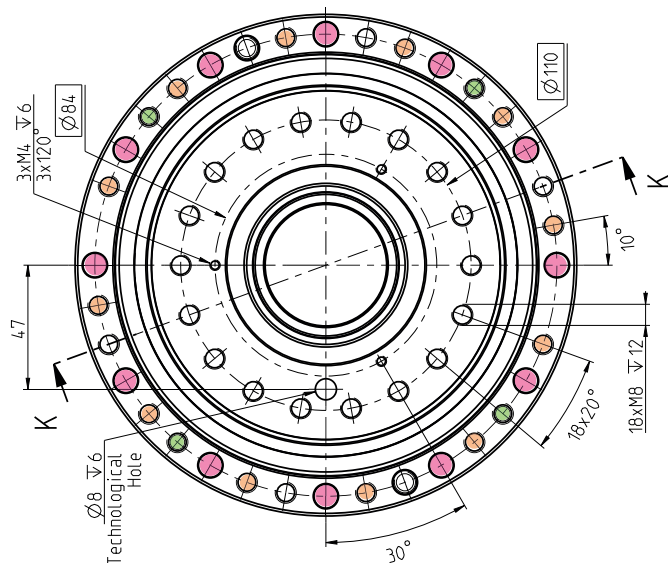
H series

TS 170 - i - H - H46

INPUT SIDE VIEW



TS 170 - i - H - H46

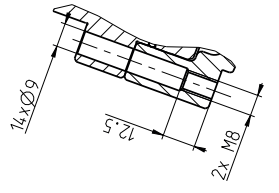
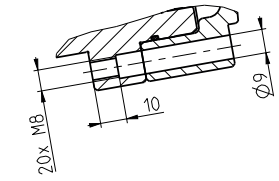
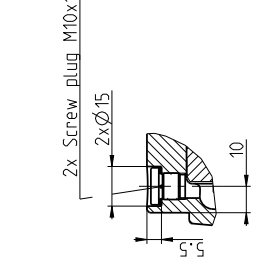
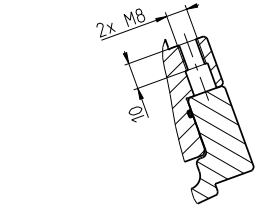


A-A

K-K

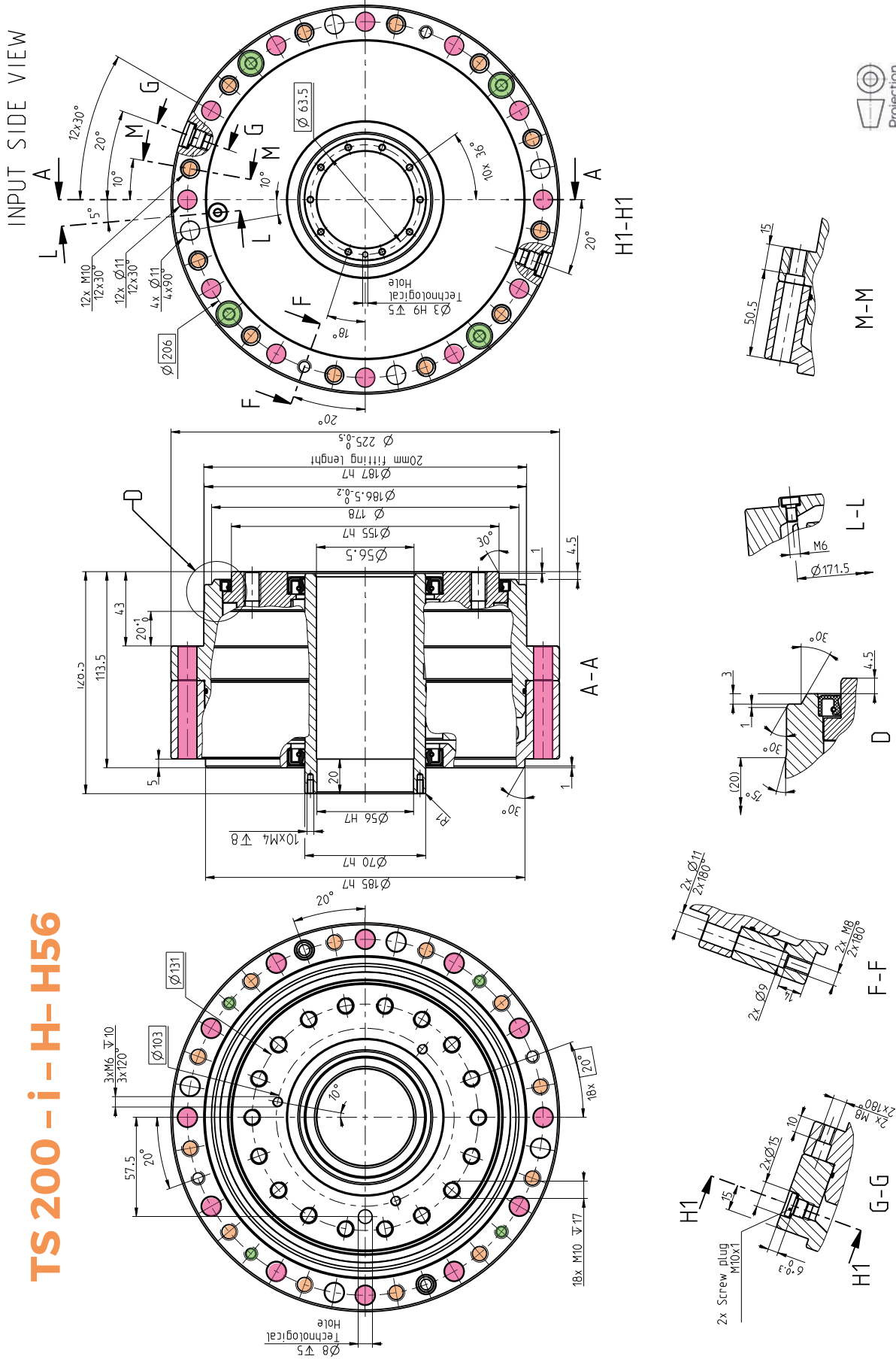
E-E

G-G



1. Use only standardized components, such as ring seals, bolts, etc.
2. Right to change without prior notice reserved.

TS 200 - i - H - H56

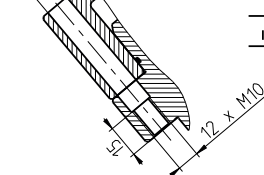
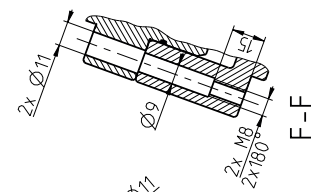
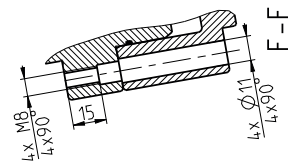
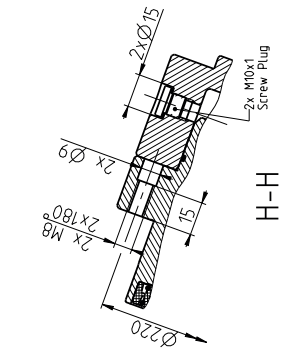
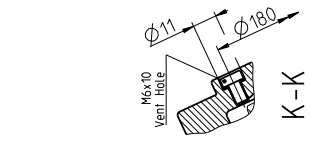
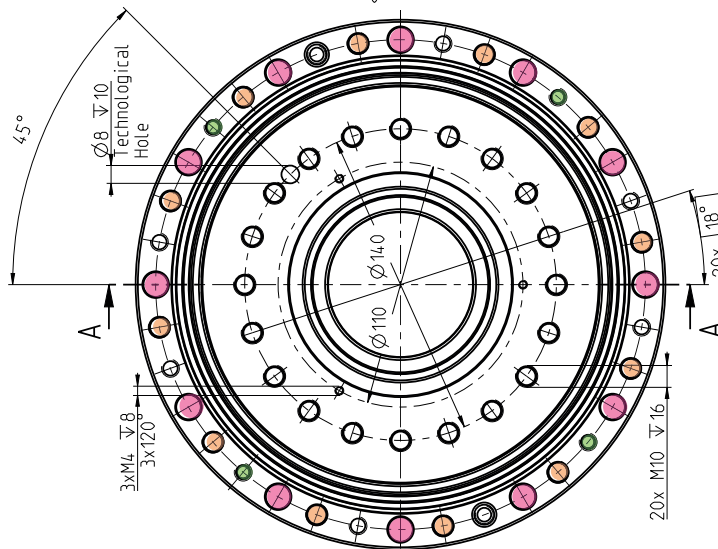
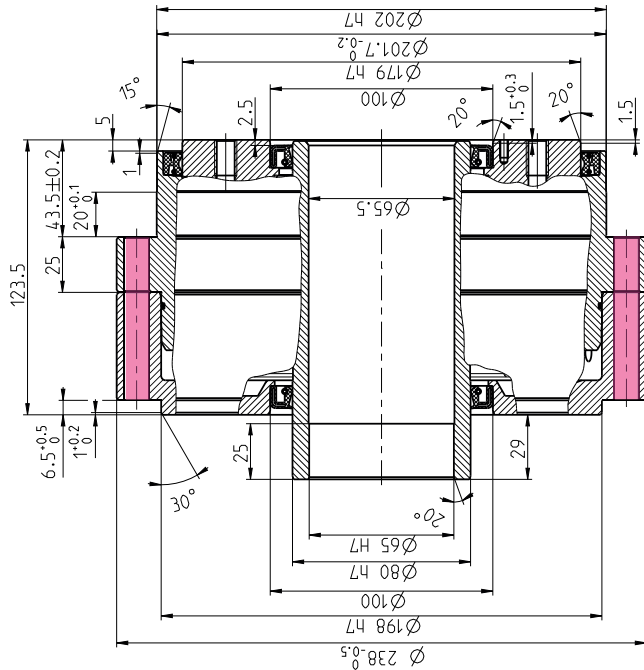
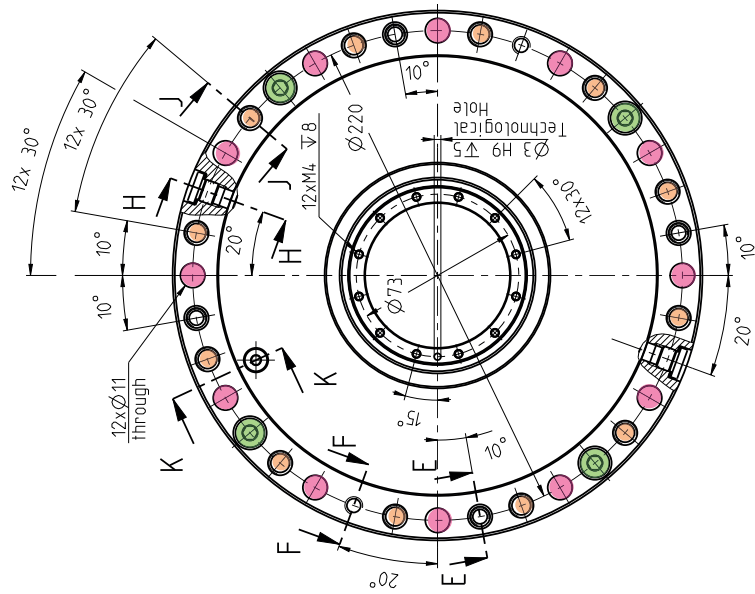


1. Use only standardized components, such as ring seals, bolts, etc.
2. Right to change without prior notice reserved.

H series

TS 220 - i - H - H 65

INPUT SIDE VIEW



1. Use only standardized components, such as ring seals, bolts, etc.
2. Right to change without prior notice reserved.



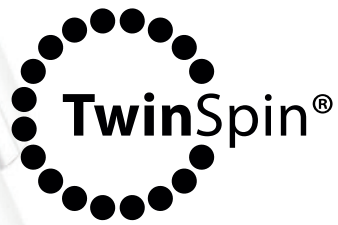


The smallest TwinSpin® compact reducer

High power density

Integrated ball bearings for low friction

Sealed and greased for life



M series

EXCELLENCE IN MOTION

M series

2.6 M SERIES



Advantages

- small dimensions and compact design
- series sealed by 2RS ball bearings
- simple installation
- zero- backlash reduction gear
- very low mass
- very high power density
- output deep groove ball bearings with very low friction
- high performance of the reduction gear
- high precision
- high torsional stiffness
- high linearity of torsional stiffness characteristics
- very low friction and high efficiency

The **M series** represents TwinSpin® high precision reduction gears of mini sizes. The M series is filled with grease for lifetime. The sealing of the M series reduction gears is secured by sealed (2RS) ball bearings, which are used as output bearings of the reduction gear, and they are also used for the housing of the input shaft of the reduction gear (slight leakage of the lubricant is allowed). Upon the customer's request, SPINEA is able to supply a completely sealed reduction gear. This design of the reduction gears allows the mounting of the load directly on the output flange or case without a need of additional bearings.

Tab. 2.6a: TwinSpin® M series mini reduction gear versions

| | |
|--------------------------------------|--|
| <p>Shape of the case</p> | <p>a) The mounting part of the case is located on the output side of the TwinSpin® high precision reduction gear.</p> <p>b) The mounting part of the case is located on the input side of the TwinSpin® high precision reduction gear.</p> <div style="text-align: right;"> </div> |
| <p>Input shaft connection</p> | <p>a) Direct connection of shafts without couplings. The motor shaft is aligned with the hole with a keyway.</p> <p>b) Indirect connection of shafts with rigid or flexible couplings</p> <p>c) Shafts are aligned according to the customer's requirements.</p> |

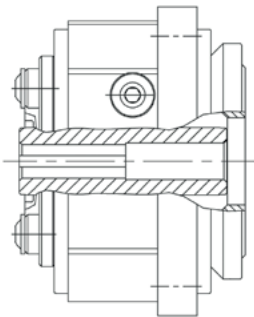
The M series high precision reduction gears are manufactured in several modifications according to the specification of the shaft and the case; see Tab. 2.6a.

Tab. 2.6b: M series ordering specifications

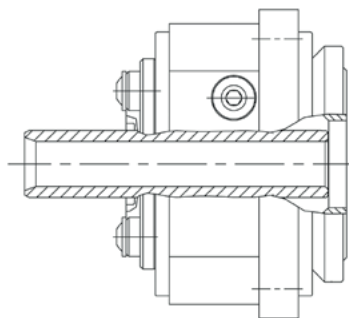
| TS - 50 - 63 - M - P6 | | | | | | |
|-----------------------|------|--------|----------------|---------------|---|--------------------------------|
| Name | Size | Ratio | Series version | Shaft version | | |
| | | | | P | H | S |
| TS | 50 | 47, 63 | M | 6 | 8 | according to a special request |

Note: An example of an ordering code of a modified TwinSpin® reduction gear with with a motor flange:
 TS 50 - 63 - M - P6- M235 - P231. The markings M235 and P231 for a specific modification are defined by the manufacturer.

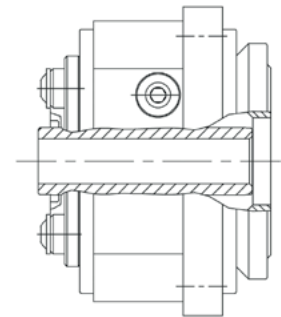
Shaft version



a) P- Shaft with keyway



b) H - Hollow shaft



c) S- Special shaft

Tab. 2.6c: M series rating table

| Size | Reduction ratio | Rated output torque | Max. acceleration / deceleration torque | Permissible output torque at emergency stop | Rated input speed | Rated output speed | Max. continuous input speed | Max. allowable input speed 1) 6) | Tilting stiffness 1) | Torsional stiffness 1) |
|--------------|-----------------|---------------------|--|--|-------------------|--------------------|-----------------------------|-------------------------------------|----------------------|------------------------|
| | i | T_R [Nm] | T_{acc} [Nm] | T_{em} [Nm] | n_R [rpm] | n_{Rout} [rpm] | n_{cmax} [rpm] | n_{max} [rpm] | M_t [Nm/arcmin] | k_t [Nm/arcmin] |
| TS 50 | 47 | 18 | 36 | 90 | 2 000 | 32 | 3 000 | 5 000 | 4 | 2.5 |
| | 63 | | | | | | | | | |

RIGHT TO CHANGE WITHOUT PRIOR NOTICE RESERVED

- 1) Mean statistical value
- 2) Load at output speed $n_{Rout} = n_R / i$. For TS 50 M at 32 [rpm]
- 3) Moment $M_{c,max}$ at $F_a=0$. If $F_a \neq 0$ see par. 3.5.1
- 4) Radial force $F_{r,max}$ for $F_a=0$. If $F_a \neq 0$ see par. 3.5.1
- 5) Axial force $F_{a,max}$ for $F_r=0$, $M_c=0$. If $M_c \neq 0$, see par. 3.5.1
- 6) At 50% $n_{c,max}$ (max input speed in cycle)
- 7) Applies to the standard version of the high precision reduction gear with the shaft connected by a keyway
- 8) a_2 is the distance of the radial force centre from the front of the output flange [m]

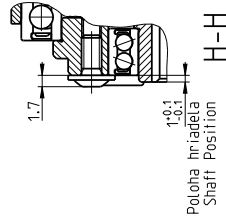
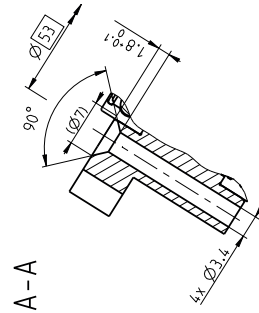
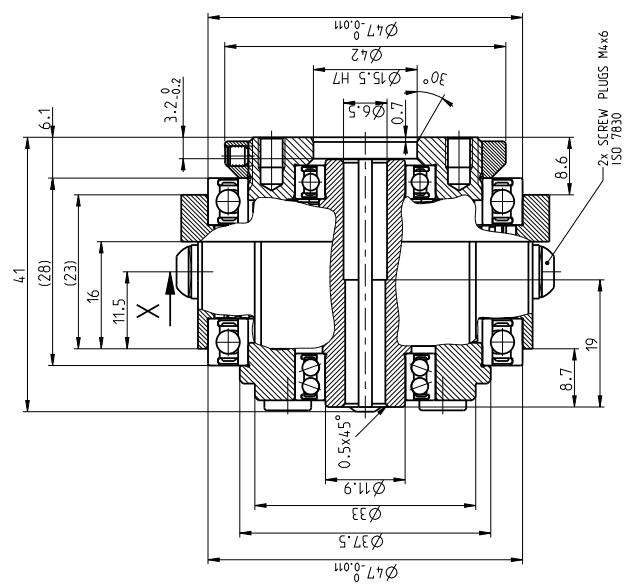
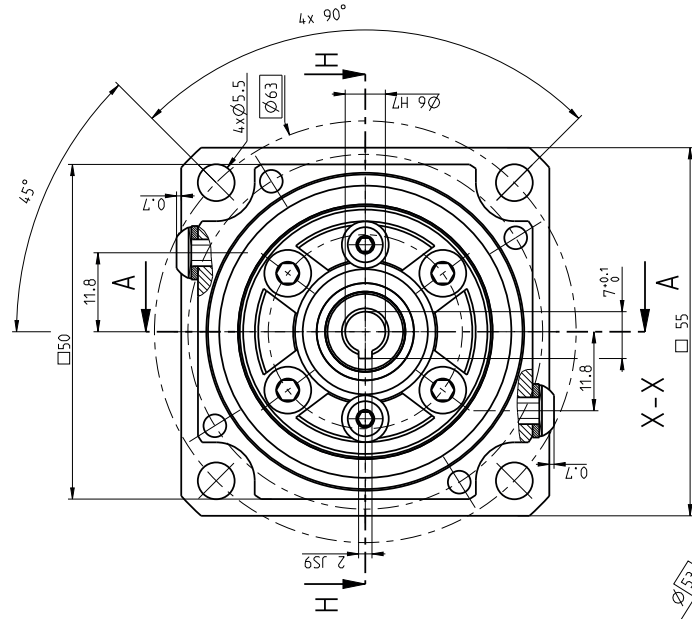
Tab. 2.6c: M series rating table - continued

| Average no-load starting torque 1) | Average back driving torque 1) | Max. lost motion | Hysteresis | Max. peak moment 2) 3) | Max radial force 2) 4) 8) | Max axial force 2) 5) | Input inertia 7) | Weight 7) |
|------------------------------------|--------------------------------|------------------|------------|------------------------|--|-----------------------|------------------------------------|-----------|
| [cNm] | [Nm] | LM [arcmin] | H [arcmin] | $M_{c\ max}$ [Nm] | F_{rR} [kN] | $F_{a\ max}$ [kN] | I [10^{-4} kgm ²] | m [kg] |
| 4 | 3 | <1.5 | <1.5 | 44 | $a_2=0$ 1.44 $a_2>0$ $0.044/(a_2+0.0305)$ | 1.9 | 0.007 | 0.47 |
| 3 | 2 | | | | | | | |

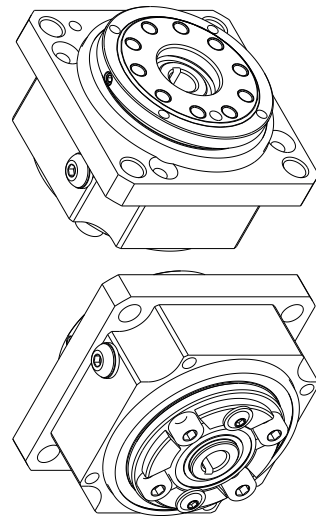
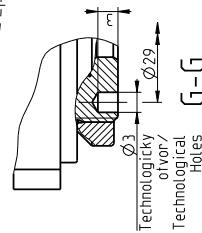
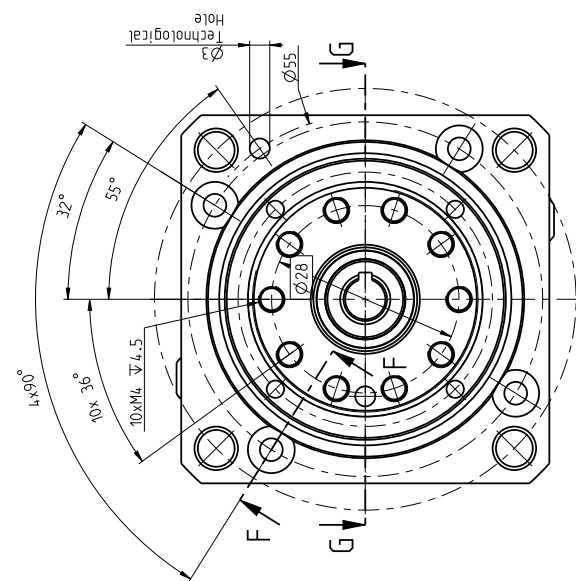
Note:
 Load values in Tab. 2.6c are valid for the nominal life of $L_{10} = 6\ 000$ [Hrs].

TS 50 - i - M - P6

INPUT SIDE VIEW



TS 50 - i - M - P6

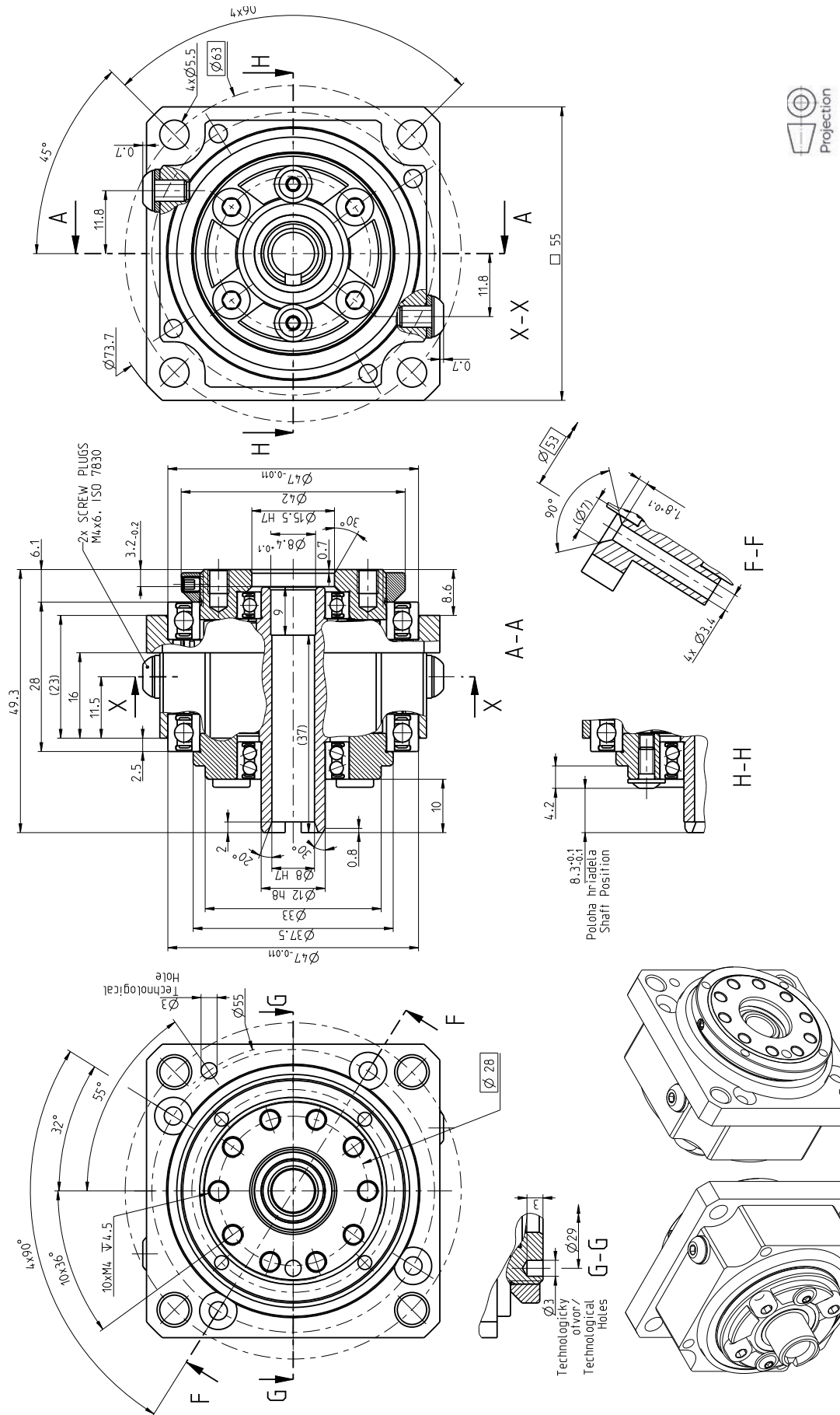


1. Use only standardized components, such as ring seals, bolts, etc.
2. Right to change without prior notice reserved.
3. Unsealed space, see the installation instructions in the TS Catalogue.

TS 50 - i - M - H8 - M826

TS 50 - i - M - H8 - M826

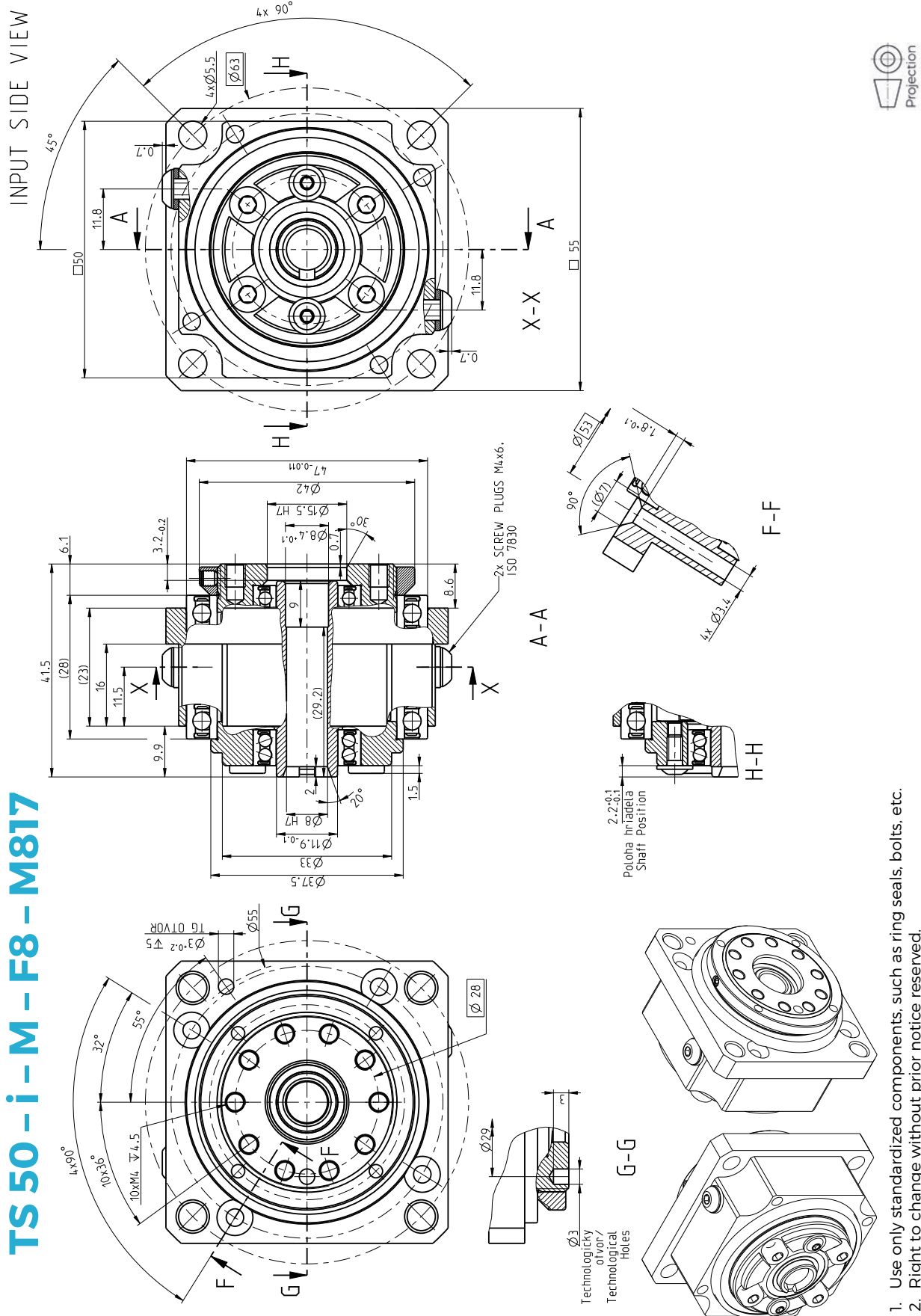
INPUT SIDE VIEW



1. Use only standardized components, such as ring seals, bolts, etc.
2. Right to change without prior notice reserved.
3. Unsealed space, see the installation instructions in the TS Catalogue.

M series

TS 50 - i - F8 - M817



1. Use only standardized components, such as ring seals, bolts, etc.
2. Right to change without prior notice reserved.
3. Unsealed space, see the installation instructions in the TS Catalogue.





3. Performance characteristics

3.1 G, GH, T, E, H, M series service life calculation

The nominal service life of the TwinSpin® reduction gear is determined by the service life of the bearings on the input shaft. This nominal service life is limited by the material fatigue of the bearings. It does not take into account other factors that may be a limit to the practical service life, such as insufficient lubrication, contamination or overload. The nominal service life is only a statistical value.

It denotes a time in operation under rated conditions during which 10% of a large number of reduction gears get damaged due to material fatigue. For further explanations or special calculations for your specific application please contact the Sales Department or your local sales representative.

The service life for a given speed and load values can be calculated as follows:

$$L_h = k \cdot \frac{n_R}{n_a} \cdot \left(\frac{T_R}{T_a} \right)^{\frac{10}{3}}$$

k – 6,000 hour service life [Hrs]

L_h – required service life [hrs]

T_a – average output torque [Nm]

n_a – average input speed [rpm]

T_R – rated output torque [Nm]

n_R – rated input speed [rpm]

3.2 M series maximum continuous input speed ($n_{c \max}$)

The maximum continuous input speed is the speed limit in the continuous operation mode S1. If higher speeds are required, please contact the sales department.

3.3 G, GH, T, E, H, M series maximum acceleration and braking torques

Due to inertial loads, the torque applied during acceleration and braking is higher than the rated value. The maximum allowable torque when the reduction gear accelerates or decelerates is shown in Tab. 2.1c, Tab. 2.2a, Tab. 2.3c, Tab. 2.4c, Tab. 2.5c, and Tab. 2.6c.

3.4 G, GH, T, E, H, M series maximum emergency stop torque (T_{em})

An emergency stop and the induced shock load may result in torque values higher than the nominal value. The maximum allowable torque value is provided in Tab. 2.1c, Tab. 2.2a, Tab. 2.3c, Tab. 2.4c, Tab. 2.5c, and Tab. 2.6c. It should be noted that its occurrence is accidental and rare, and it is not part of a regular duty cycle in any way.

3.5 Allowable radial-axial load and moment load on the output flange of the G, GH, T, E, H series

Radial and axial loads act independently thanks to the integrated radial-axial output bearings. The allowed radial load (F_r) is provided in the rating table in Chapter 2. The moment (Fig. 3.6a and Fig. 3.6b) is expressed as follows:

$$M_c = F_r \cdot a + F_a \cdot b$$

a – radial force F_r arm [m]

b – axial force F_a arm [m]

M_c – moment [Nm]

F_r – radial load [N]

F_a – axial load [N]

The allowable load for the moment (M_c) and the axial force (F_a) is shown in Fig. 3.5. A point with coordinates (M_c , F_a) must lie in the area under the line of the selected reduction gear. For example, in the case of TS 170 T, E, at an output speed of 15 rpm, $L_{10} = 6\,000$ hrs and moment $M_c = 1\,500$ Nm, the maximum axial force may be 10.7 kN (see Fig. 3.5). The allowable radial and axial loads determine the allowable dynamic load that can be applied on a reduction gear. For more detailed calculations for specific conditions please contact the sales department or your local sales representative.

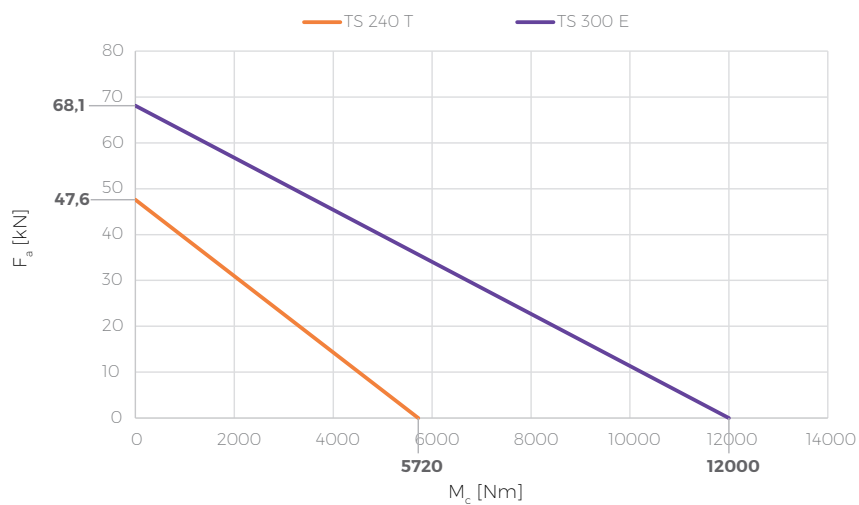
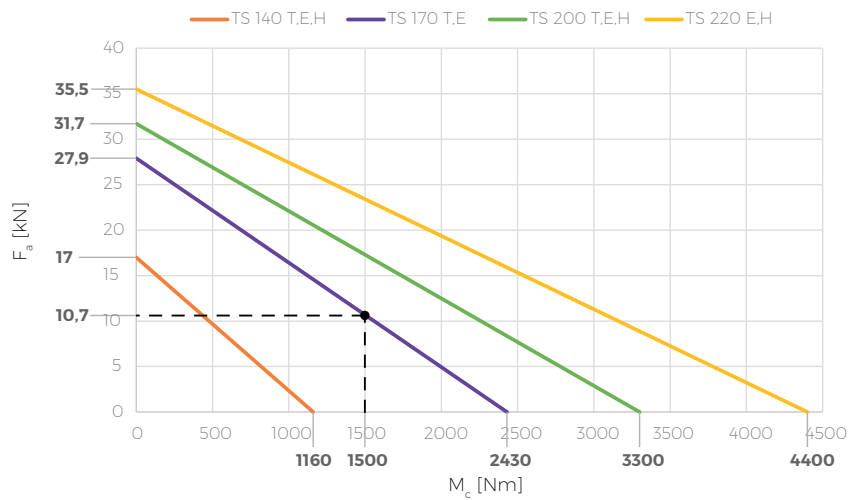
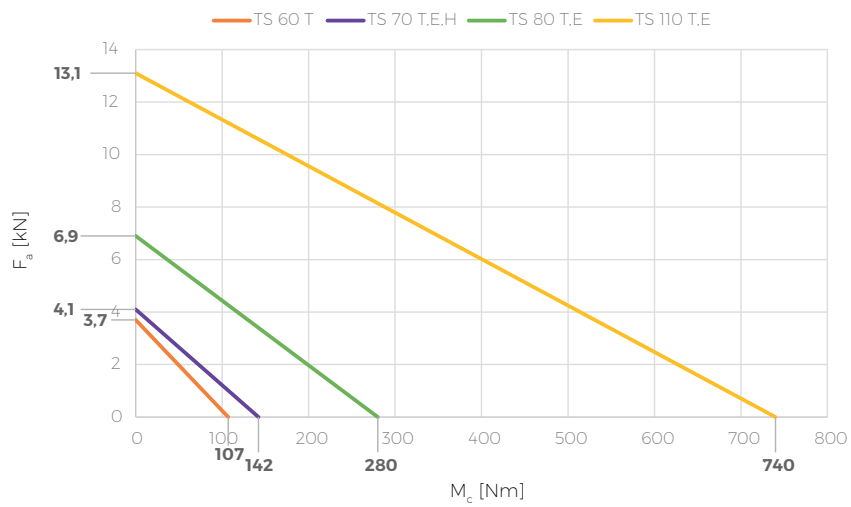
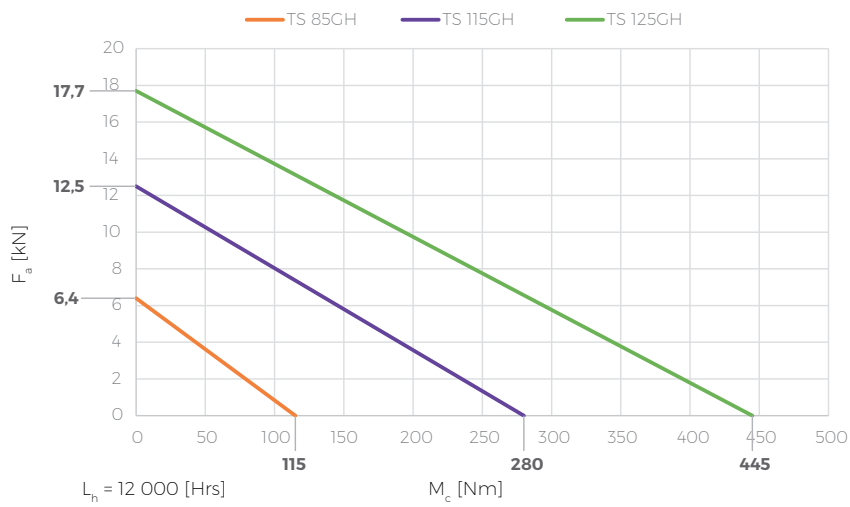
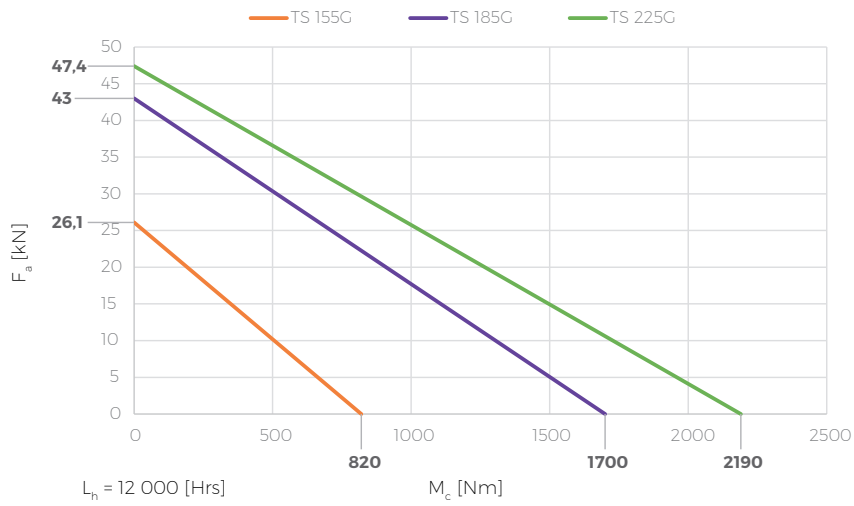
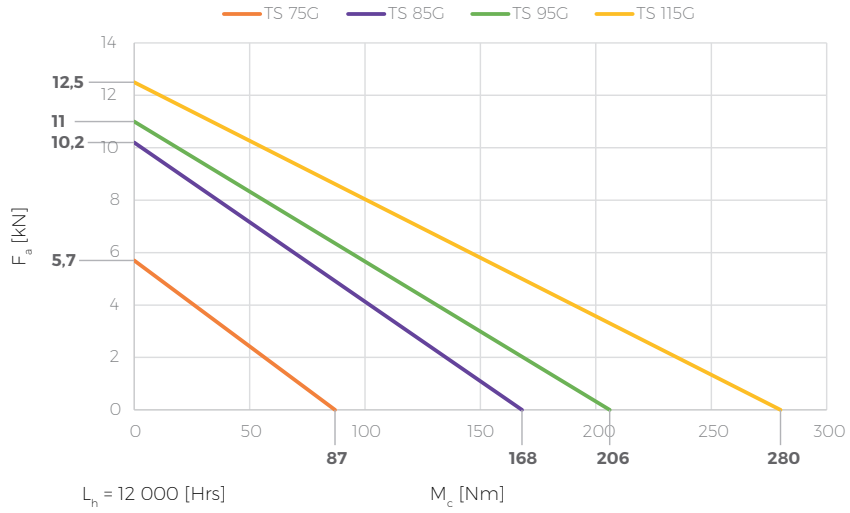


Fig. 3.5: Relation between the moment and the axial force



3.5.1 Allowable radial-axial load and moment on the output flange of the M series

The output flange of the TwinSpin® M series reduction gear is able to transmit external loads from the radial force F_r , axial force F_a and moment M_c . The moment is expressed as follows

$$M_c = F_r \cdot a + F_a \cdot b$$

M_c – moment [Nm]

F_r – radial load [N]

F_a – axial load [N]

b – arm of force F_a [m]

a_1 – perpendicular distance between the centre of the output bearings and the face of the output flange [m]

a_2 – perpendicular distance between the vector of force F_r and the face of the output flange [m]

a_3 – perpendicular distance between the centre of the output bearing A and the face of the output flange [m]

$a = a_1 + a_2$ – arm of force F_r in relation to the centre of the output bearings [m]

A, B – identification of the bearings

A – bearing of the output side of the reduction gear

B – bearing of the input side of the reduction gear

R_{Ax} , R_{Ay} , R_{Bx} , R_{By} – reaction identification on x-axis (axial direction) and y-axis (radial direction) in bearings A,B

L_1 – distance between the centres of the output bearings [m]

$L_2 = a_2 + a_3$ – perpendicular distance between the vector of force F_r and the centre of the output bearing A [m]

The moment applied to the most loaded bearing A according to Fig. 3.5.1 is expressed as follows:

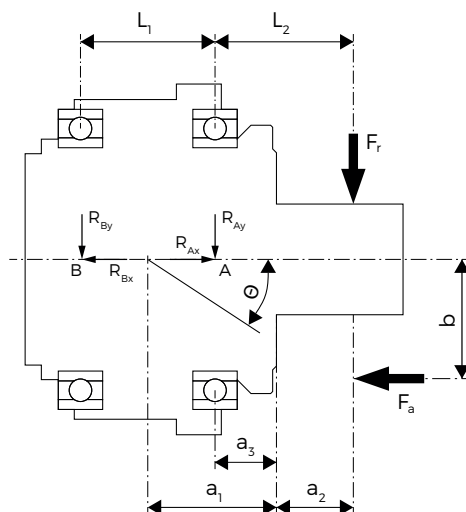


Fig. 3.5.1: Loading of the M series reduction gear and the angle of tilt

$$M_c = F_r \cdot (a_2 + a_3) + F_a \cdot b = F_r \cdot L_2 + F_a \cdot b$$

When checking external loads of the TwinSpin® M series reduction gear, proceed as follows:

a) Allowable axial load

$$F_a \leq F_{a \max}$$

according to the Tab. 3.5.4

b) Allowable moment

$$M_c \leq M_{c \max}$$

according to the Tab. 3.5.5

c) Allowable radial load

$$F_r \leq F_{r \max}$$

according to the Tab. 3.5.6

d) Equivalent load

$$P_{IA} \leq P_{I \max}$$

according to the Tab. 3.5.3

Tab. 3.5.1: Distances a_1 , a_3 and L_1 from Fig. 3.5.1

| TS series M | TS 50 |
|--------------------|--------|
| Distance a_1 [m] | 0.02 |
| Distance a_3 [m] | 0.0095 |
| Distance L_1 [m] | 0.021 |

3.5.2 M series output bearings load capacity

The standard version of the TwinSpin® M series reduction gear has two sealed (2RS) deep groove ball bearings as output bearings. Tab. 3.5.2a describes the basic dynamic and static load capacity of the two bearings and Table 3.5.2b is used for the calculation of the equivalent loading of one output deep groove ball bearing of the reduction gear.

Tab. 3.5.2a: Capacity of M series deep groove ball bearings

| TwinSpin® M series reduction gear | TS 50 |
|--|-------|
| Basic dynamic load capacity C_r [kN] | 4.75 |
| Basic static load capacity C_0 [kN] | 3.85 |

Tab. 3.5.2b: Calculation of the equivalent load of one M series deep groove ball bearing

| Equivalent Radial Load | Dynamic equivalent radial load $P_r = X \cdot R_y + Y \cdot R_x$ Values X and Y are in the table on the right | R_x/C_0 | e | $R_x/R_y \leq e$ | | $R_x/R_y > e$ | |
|------------------------|---|-----------|------|---|-------|---------------|------|
| | | | | X | Y | X | Y |
| | | | | Static equivalent radial load = $0.6 R_y + 0.5 R_x$ | 0.014 | 0.19 | |
| | | 0.028 | 0.22 | | | | 1.99 |
| | | 0.056 | 0.26 | | | | 1.71 |
| | | 0.084 | 0.28 | | | | 1.55 |
| | | 0.11 | 0.30 | 1 | 0 | 0.56 | 1.45 |
| | | 0.17 | 0.34 | | | | 1.31 |
| | if value | 0.28 | 0.38 | | | | 1.15 |
| | $P_{or} < R_y$, $P_{or} = R_y$ | 0.42 | 0.42 | | | | 1.04 |
| | | 0.56 | 0.44 | | | | 1.00 |

Where R_x , R_y are reactions in bearings A, B, i.e. identified as R_{Ax} , R_{Ay} , R_{Bx} , R_{By} according to Fig. 3.5.1.

3.5.3 M series output bearings allowable load

The tables of nominal values Tab. 3.5.4, Tab. 3.5.5, and Tab. 3.5.6, show the allowable radial force $F_{r \max}$, allowable axial load $F_{a \max}$ and allowable moment $M_{c \max}$ applied to the output flange of the TwinSpin® M series reduction gear according to Fig. 3.5.1. This is the load at which the gear achieves the nominal service life of its output bearing $L_{10} = 6\,000$ Hrs at the nominal output speed $n_{r \text{out}}$. The equivalent radial load can be determined from the formula:

$$L_{10} = \frac{10^6}{60 \cdot n} \cdot \left(\frac{C_r}{P_r}\right)^3 \quad P_r = \frac{C_r}{(L_{10} \cdot 60 \cdot n \cdot 10^{-6})^{\frac{1}{3}}}$$

L_{10} – service life [hour]

n – operational speed [rpm]

C_r – basic dynamic load capacity of the bearing [N]

P_r – equivalent radial load [N]

Tab. 3.5.3: Maximum equivalent radial load of the M series output bearing

| | |
|--|-------|
| M series high precision reduction gear ($L_{10} = k = 6\,000$ [Hrs], $n = n_{r \text{out}} = 32$ [rpm]) | TS 50 |
| Ratio i | 63 |
| Equivalent max. radial load of the output bearing $P_{r \max}$ [N] | 2 100 |

3.5.4 M series allowable axial load $F_{a \max}$

Tab. 3.5.4 shows the maximum allowable axial load $F_{a \max}$ where the arm of the force is $b = 0$ (Fig. 3.5.1) and $F_r = 0$ and $M_c = 0$.

 Tab. 3.5.4: Allowable axial load $F_{a \max}$ on the M series output bearing

| | |
|--|-------|
| M series high precision reduction gear ($L_{10} = k = 6\,000$ [Hrs], $n = n_{r \text{out}} = 32$ [rpm]) | TS 50 |
| Ratio i | 63 |
| Allowable axial load $F_{a \max}$ [N] ($F_r = 0$, $M_c = 0$, $b = 0$) | 1 900 |

3.5.5 M series allowable moment $M_{c \max}$

When only an external moment M_c is applied to the output flange of the TwinSpin® M series reduction gear, the following applies to the maximum value $M_{c \max}$ of the moment in Tab. 3.5.5:

$$M_{c \max} = P_{r \max} \cdot L_1$$

Tab. 3.5.5: Allowable moment on the output flange of the M series high precision reduction gear

| | |
|---|-------|
| M series high precision reduction gear ($L_{10} = k = 6\,000$ [Hrs], $n = n_{R.out} = 32$ [rpm]) | TS 50 |
| Allowable moment $M_{c \max}$ [Nm] ($F_a = 0$) | 44 |

3.5.6 M series allowable radial load $F_{r \max}$

The allowable radial load values $F_{r \max}$ when $F_a = 0$ (Tab. 3.5.6) are calculated from the formula:

$$F_{r \max} = \frac{M_{c \max}}{(a_2 + a_3 + L_1)}$$

Tab. 3.5.6: Allowable radial load on the M series output flange

| | |
|---|---------------------|
| M series high precision reduction gear ($L_{10} = k = 6\,000$ [Hrs], $n = n_{R.out} = 32$ [rpm]) | TS 50 |
| Allowable radial load $F_{r \max}$ [N] | $44/(a_2 + 0.0305)$ |
| Allowable radial load for $a_2 = 0$, $F_{r \max}$ [N] | 1 440 N |

Where a_2 is the perpendicular distance between the vector of force F_r and the face of the output flange [m] Fig. 3.5.1

3.5.7 M series output flange allowable load when applying both F_r radial force and F_a axial force

When both a radial force F_r and an axial force F_a are applied to the output flange, then, according to Tab. 3.5.2b, the equivalent load is calculated as follows:

$$P_{rA} = X \cdot \left(\frac{F_a \cdot b + F_r \cdot (a_2 + a_3)}{L_1} + F_r \right) + Y \cdot F_a$$

$$P_{rA} = X \cdot \left(\frac{M_c}{L_1} + F_r \right) + Y \cdot F_a$$

Where the coefficients X and Y are calculated according to Tab. 3.5.2b as follows:

$$\frac{R_{Ax}}{C_{0r}} = \frac{F_a}{C_{0r}} \rightarrow X, Y$$

$$\frac{R_{Ax}}{R_{Ay}} = \frac{F_a}{\frac{F_a \cdot b + F_r \cdot (a_2 + a_3)}{L_1} + F_r} \rightarrow X, Y$$

$$\frac{R_{Ax}}{R_{Ay}} = \frac{F_a}{\frac{M_c}{L_1} + F_r} \rightarrow X, Y$$

3.6 G, GH, T, E, H, M series output flange tilting stiffness and deflection angle

The TwinSpin® reduction gears are able to withstand external forces and moment loads by means of integrated output bearings. When the output flange is loaded, the flange deflection angle is proportional to the applied moment. The tilting stiffness (M_t) is a moment at which the output flange deflects by an angle $\Theta = 1'$. The M_t values are specified in the rating table in Chapter 2. The tilting angle of the output flange (Fig. 3.6a, Fig. 3.6b and Fig. 3.5.1) can be determined as follows:

$$\Theta = \frac{F_r \cdot a + F_a \cdot b}{M_t}$$

Θ – output flange tilting angle [arcmin]

M_t – tilting stiffness [Nm/arcmin]

F_r – radial load [N]

F_a – axial load [N]

a – arm of force F_r [m]

$$a = a_1 + a_2$$

$$a_1 = L / 2$$

b – arm of force F_a [m]

Values a_1 for G, GH series

| Size | TS 75 | TS 85 | TS 95 | TS 115 | TS 125 | TS 155 | TS 185 | TS 225 |
|-------------------|-------|-------|-------|--------|--------|--------|--------|--------|
| Values a_1 [mm] | 11 | 13.5 | 13 | 13 | 15.5 | 18 | 23 | 26 |

If the reducer is fixed on both sides then
the radial load is $2 \times F_r$.

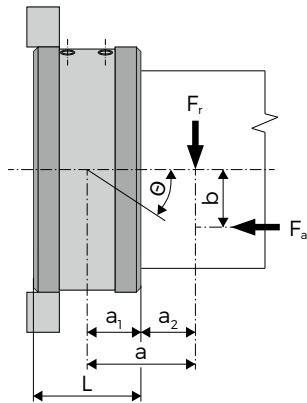


Fig. 3.6a: Load and moment on the T, E, H, M series output flange

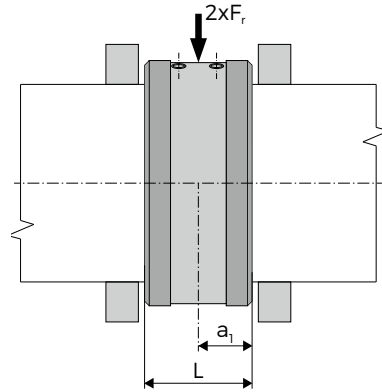


Fig. 3.6b: Load and moment on the T, E, H series output flange

3.7 G, GH, T, E, H, M series lost motion, hysteresis and torsional stiffness

If the input shaft and the case are fixed and a torque is applied to the output flange, then the load diagram has the shape of a hysteresis curve (Fig. 3.7a).

The transmission mechanism of TwinSpin® reduction gears is manufactured and assembled in such a way that there is zero back-lash in the gear. Hysteresis H expresses the amount of friction in the reduction gear. The hysteresis of the torsional turn H [arcmin] is measured as an angular difference determined by the intersections of the hysteresis curve with the turn axis at point $T_p = 0$ [Nm].

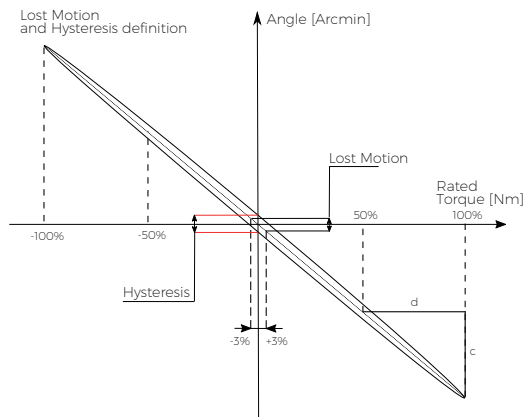


Fig. 3.7a: Hysteresis curve and the definition of stiffness

Torsional stiffness (k_t) is defined as follows:

$$k_t = \frac{d}{c}$$

Torsional stiffness and lost motion values are provided in the rating table in Chapter 2. The torsional stiffness values are statistical values for a particular reduction ratio. High precision reduction gears with hysteresis and lost motion of ≤ 0.6 arcmin can be supplied on request.

The hysteresis characteristic of TS 140-139-TB with lost motion under 0.5 arcmin is illustrated in Fig. 3.7b.

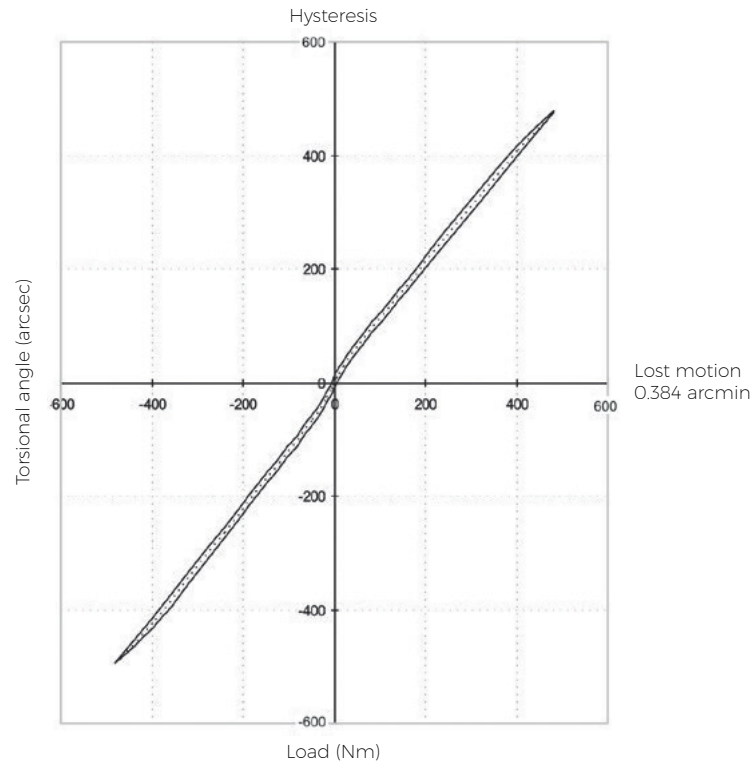


Fig. 3.7b: Hysteresis curve of TS 140-139-TB

3.8 G, GH, T, E, H, M series torsional vibrations

Torsional vibration is indicated in the peripheral direction of an inertia load driven by the reduction gear. Low vibration is extremely important for applications where high precision contouring is required. For example, a tool centre point of a robot end point has to follow a desired trajectory as precisely as possible. If robot joints vibrate, the trajectory tracking is poor. Added axes of a machine tool is another application example where very smooth running of a high precision reduction gear is required.

An accelerometer installed on a defined lever arm registers the vibration of an inertia load. A reference measurement of peripheral acceleration and position deviation is shown in Fig. 3.8. TwinSpin® runs extremely smoothly. For an input speed higher than 500 rpm the peripheral deviation is about 10 μm . The value of the external diameter amplitude LFD/LFA stabilizes when the input speed reaches and exceeds 900 rpm. For that reason the maximum input speed 900 rpm was chosen for the evaluation of torsional vibration.

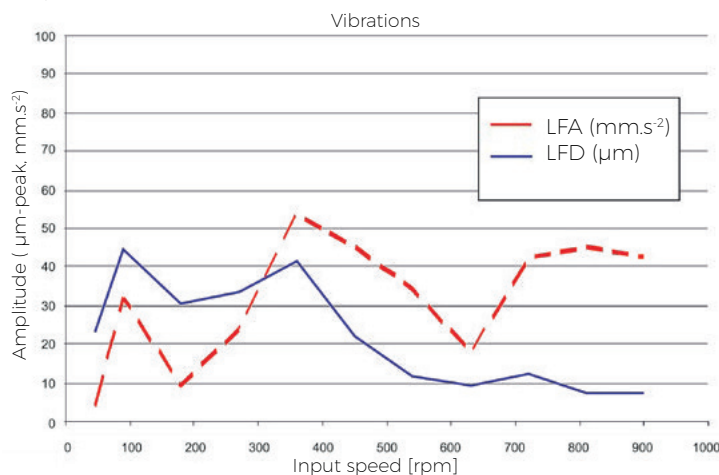


Fig. 3.8: Vibrations of TS 170-105-TC

3.9 G, GH, T, E, H, M series angular transmission accuracy

The angular transmission error is the difference between the theoretical output angle of rotation and the actual angle of rotation. The angular transmission error of the TwinSpin® high precision reduction gear is typically 1 arcmin or less. Fig. 3.9 shows an example of the angular transmission error measured on a specific TwinSpin® reduction gear TS 140-139-TB. The influence of the load on the angular transmission accuracy is relatively low.

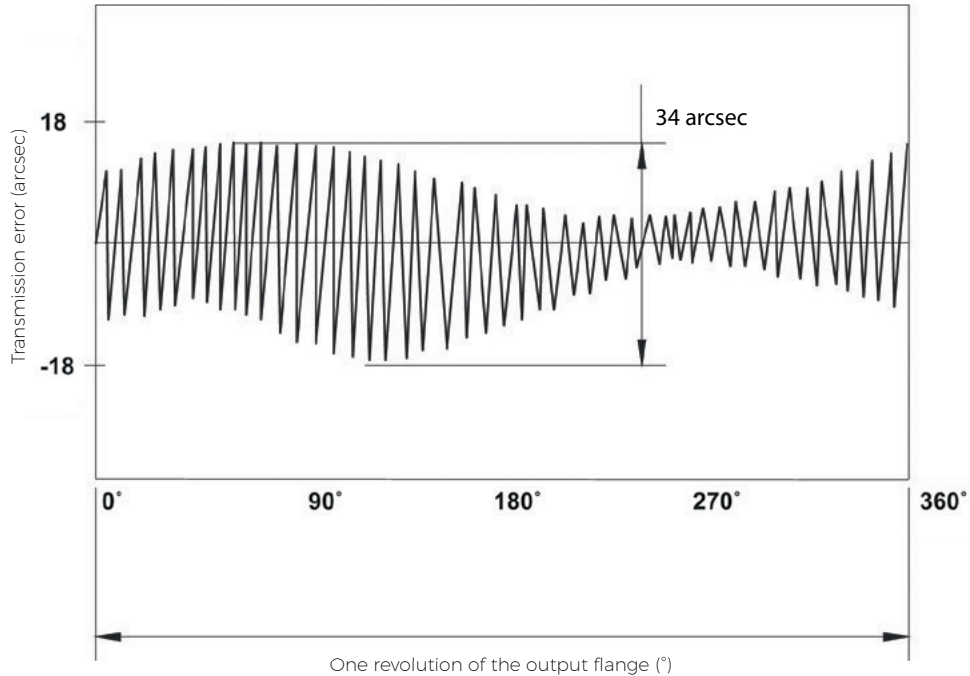


Fig. 3.9: Angular transmission error measurement

Measuring conditions
 Model: TS 140-139-TB
 Load conditions: no load

3.10 G, GH, T, E, H, M series no-load starting torque

The no-load starting torque is a quasi-static torque required to start rotation of the input shaft, if no load is applied to the output flange. The rating tables provide values for the starting torque, statistically evaluated from current production tests. Attributes in the table are specified only for a temperature of 20 °C. For a temperature of the reduction gear lower than 20°C there will be a higher no load starting torque. For a specific application please consult with the manufacturer.

3.11 G, GH, T, E, H, M series back-driving torque

The back-driving torque is the torque applied to the output flange that is required to start rotation of the input shaft under no-load. Chapter 2 provides values for back-driving torque, statistically evaluated from the current production tests. Attributes in the table are specified only for a temperature of 20 °C. For a temperature of the reduction gear lower than 20°C there will be a higher no load starting torque. For a specific application please consult with the manufacturer.

3.12 G, GH, T, E, H, M series maximum moment on the input shaft ($M_{c\ in}$)

Since the input shaft is supported on both sides by bearings, radial loads $F_{r\ in}$ may be applied. The moment on the input shaft resulting from a radial load (Fig. 3.12a T, E, H series Fig. 3.12b M series) can be calculated as follows:

$$M_{c\ in} - \text{allowable moments [Nm]}$$

$$M_{c\ in} = F_{r\ in} \cdot a \quad - \text{valid for T, E, H series}$$

$$M_{c\ in} = F_{r\ in} \cdot a_{in} + F_{a\ in} \cdot b_{in} \quad - \text{valid for M series}$$

$$a \quad - \text{load force arm [m]}$$

$$F_{r\ in} \quad - \text{radial load [N]}$$

Allowable moments $M_{c\ in}$ on the input shaft are provided in Tab. 3.12.

Tab. 3.12: Allowable moment $M_{c_{in}}$ on the input shaft under the conditions specified in the parameter tables of Chapter 2

| Size | TS 50 | TS 60 | TS 70 | TS 80 | TS 110 | TS 140 | TS 140 | TS 170 | TS 170 | TS 200 | TS 200 | TS 220 | TS 220 | TS 240 | TS 300 |
|-------------------|------------|------------|-------------------|----------------|----------------|----------------|-------------|--------------------|-------------|-----------------|-------------|--------------|--------------|--------------|--------------|
| $M_{c_{in}}$ [Nm] | M series 3 | T series 6 | T, E, H series 11 | T, E series 16 | T, E series 35 | T, E series 68 | H series 25 | T, E, H series 126 | H series 60 | T, E series 157 | H series 95 | E series 210 | H series 127 | T series 260 | T series 378 |

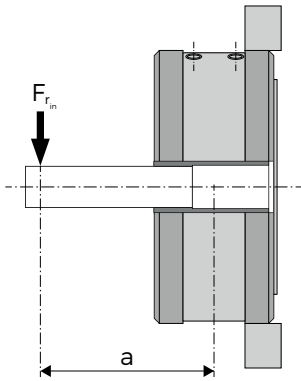


Fig. 3.12a: Radial load of the T, E, H series input shaft

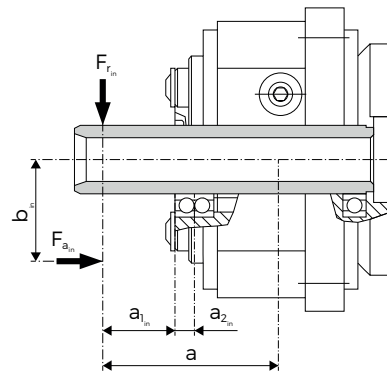
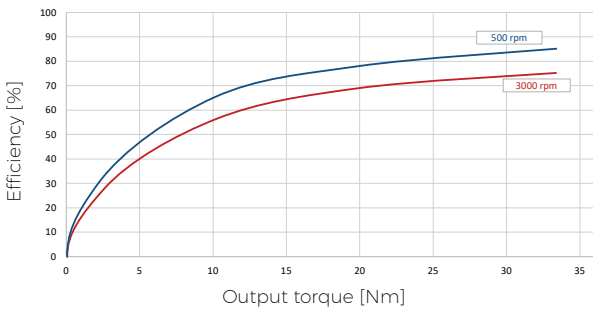


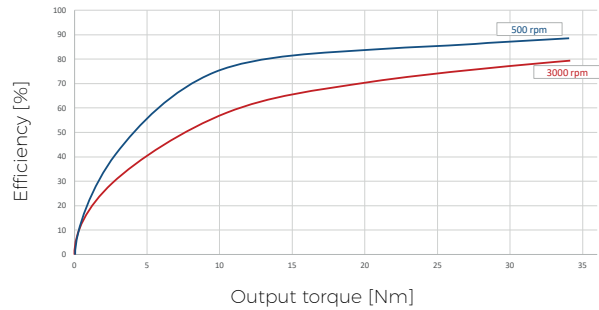
Fig. 3.12b: Radial load of the input shaft M series

3.13 G series efficiency chart

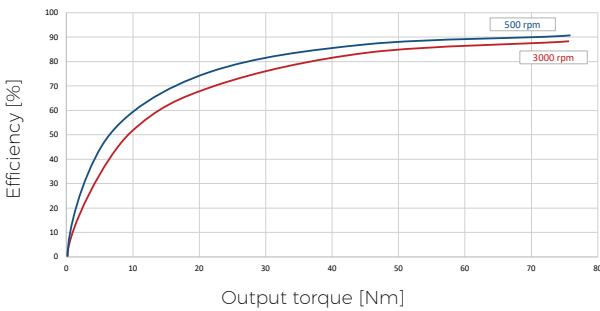
The efficiency of the TwinSpin® reduction gears depends on the input speed, output load, viscosity of lubricant, operational temperature and Lost Motion.



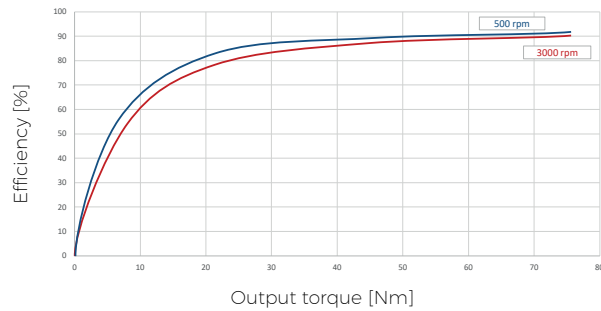
TS 75G, ratio 63 at 25°C
 H = 0.39 arcmin
 LM = 0.86 arcmin



TS 75G, ratio 63 at 40°C
 H = 0.39 arcmin
 LM = 0.86 arcmin



TS 85G, ratio 33 at 25°C
 H = 0.59 arcmin
 LM = 0.8 arcmin



TS 85G, ratio 33 at 40°C
 H = 0.59 arcmin
 LM = 0.8 arcmin

Fig. 3.13: Efficiency charts

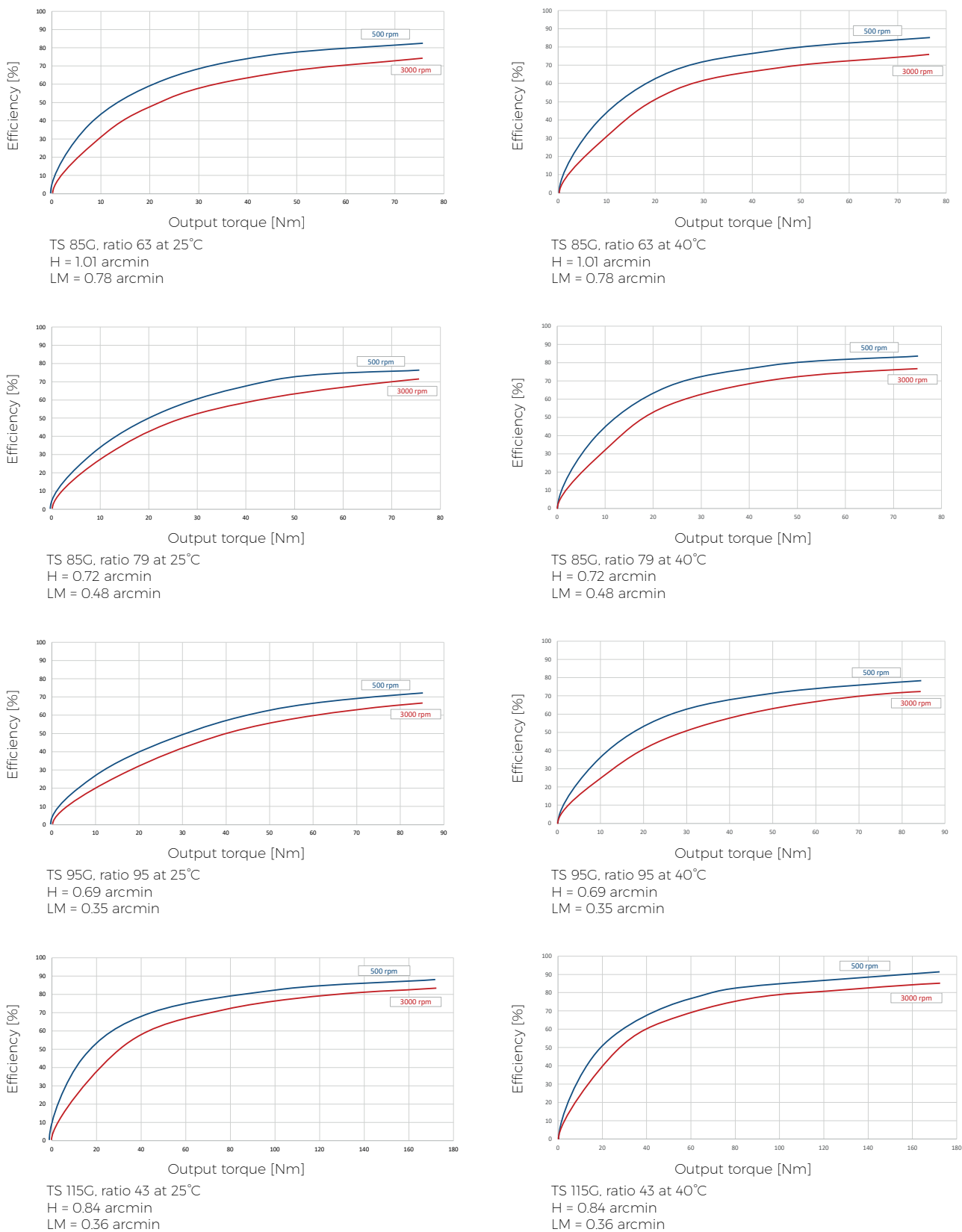
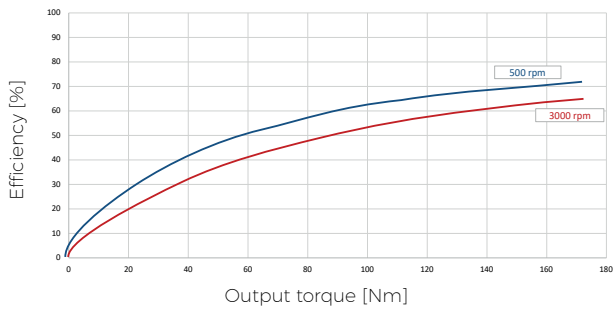
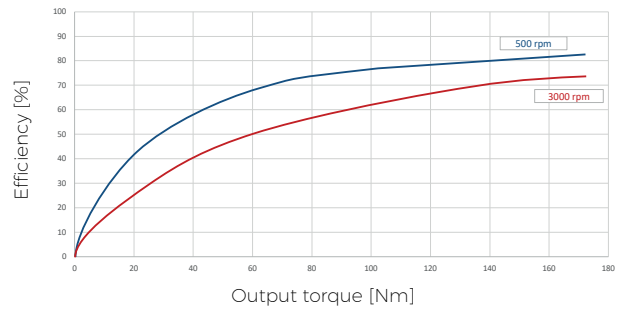


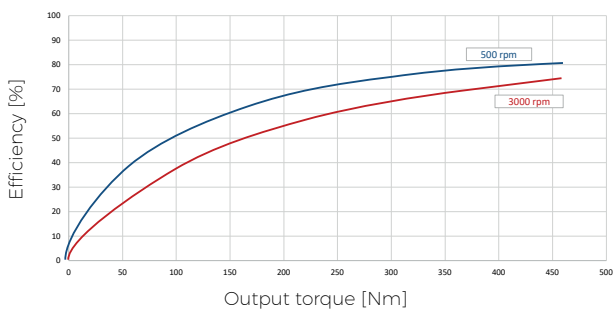
Fig. 3.13: Efficiency charts



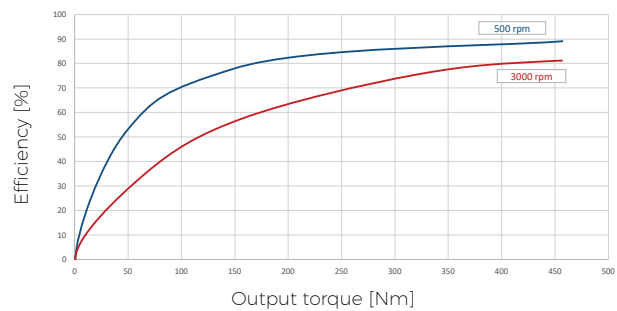
TS 115G, ratio 123 at 25°C
H = 0.96 arcmin
LM = 0.48 arcmin



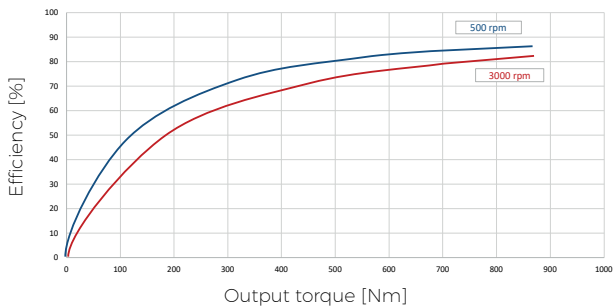
TS 115G, ratio 123 at 40°C
H = 0.96 arcmin
LM = 0.48 arcmin



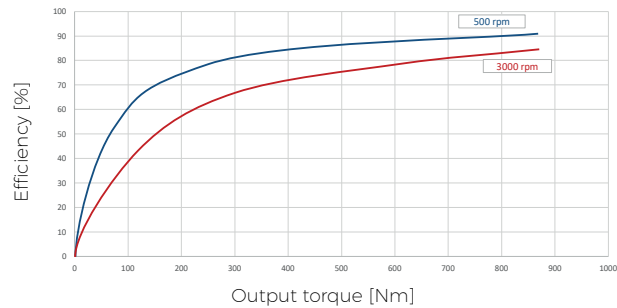
TS 155G, ratio 109 at 25°C
H = 0.49 arcmin
LM = 0.73 arcmin



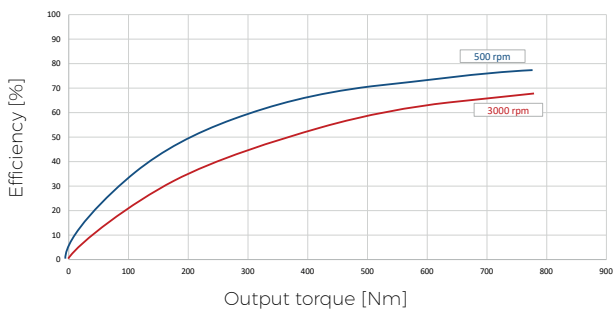
TS 155G, ratio 109 at 40°C
H = 0.49 arcmin
LM = 0.73 arcmin



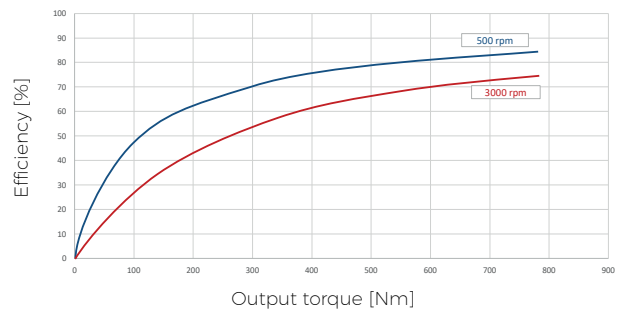
TS 185G, ratio 57 at 25°C
H = 0.3 arcmin
LM = 0.47 arcmin



TS 185G, ratio 57 at 40°C
H = 0.3 arcmin
LM = 0.47 arcmin

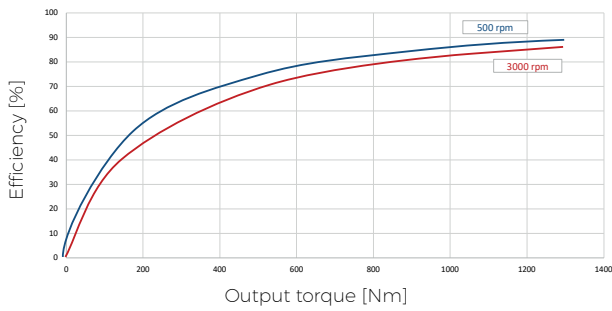


TS 185G, ratio 117 at 25°C
H = 0.48 arcmin
LM = 0.37 arcmin

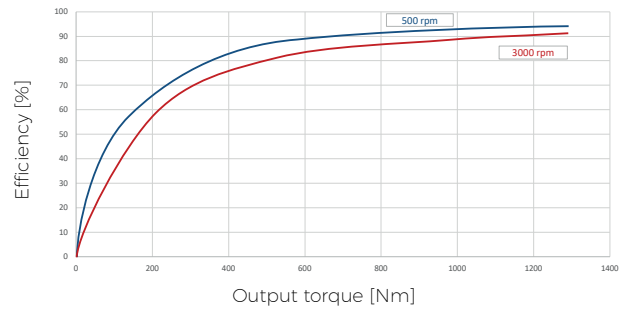


TS 185G, ratio 117 at 40°C
H = 0.48 arcmin
LM = 0.37 arcmin

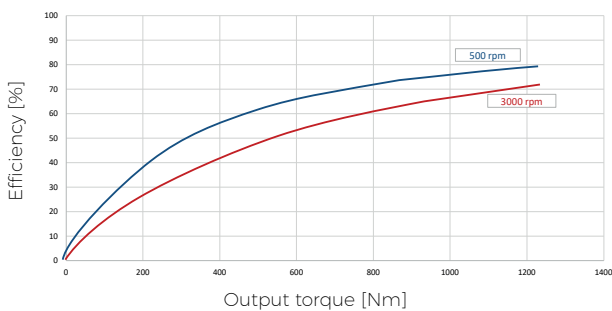
Fig. 3.13: Efficiency charts



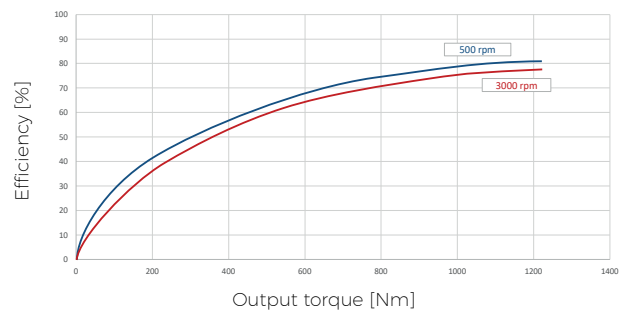
TS 225C, ratio 55 at 25°C
H = 0.31 arcmin
LM = 0.41 arcmin



TS 225C, ratio 55 at 40°C
H = 0.31 arcmin
LM = 0.41 arcmin



TS 225G, ratio 137 at 25°C
H = 0.4 arcmin
LM = 0.38 arcmin

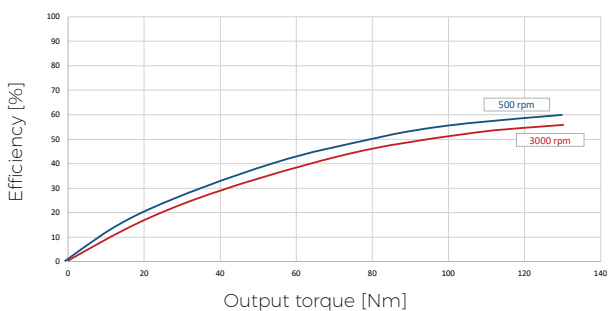


TS 225G, ratio 137 at 40°C
H = 0.4 arcmin
LM = 0.38 arcmin

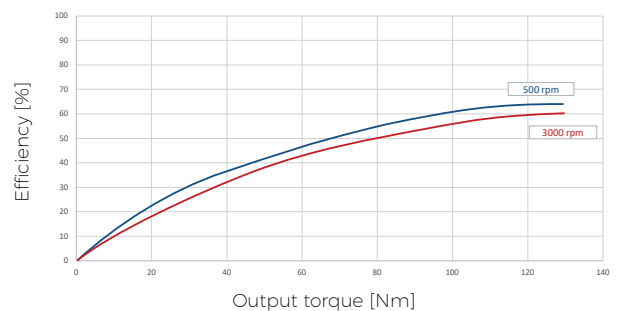
Fig. 3.13: Efficiency charts

3.14 GH series efficiency chart

The efficiency of the TwinSpin® reduction gears depends on the input speed, output load, viscosity of lubricant, operational temperature and Lost Motion.



TS 115GH, ratio 103 at 25°C
H = 0.74 arcmin
LM = 0.43 arcmin



TS 115GH, ratio 103 at 40°C
H = 0.74 arcmin
LM = 0.43 arcmin

Fig. 3.14: Efficiency charts

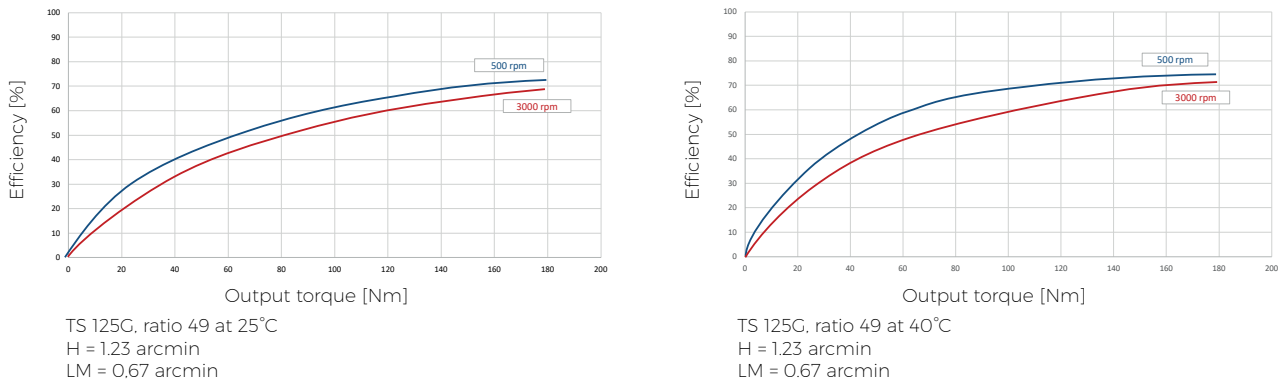


Fig. 3.14: Efficiency charts

3.15 G series no-load running torque

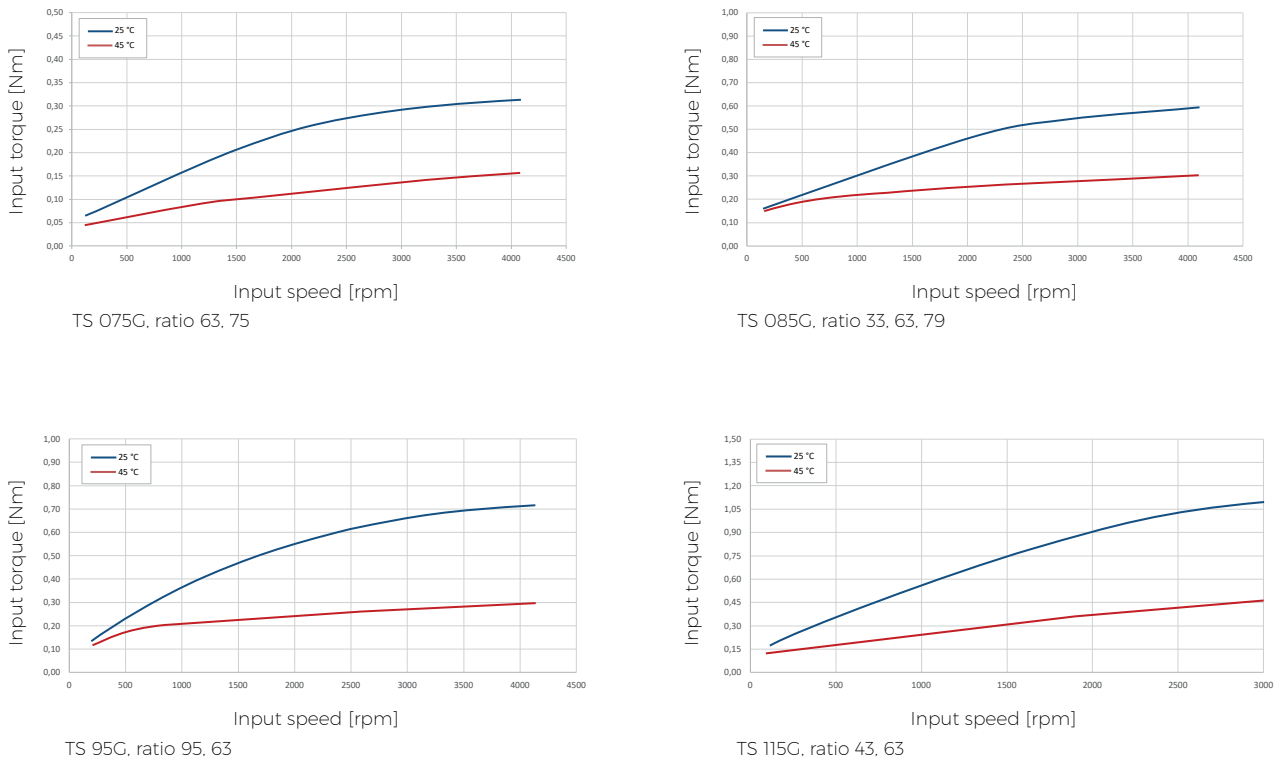
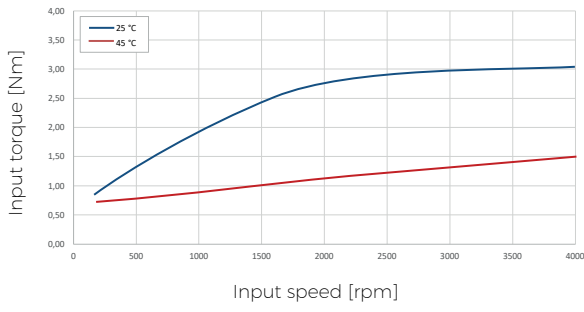
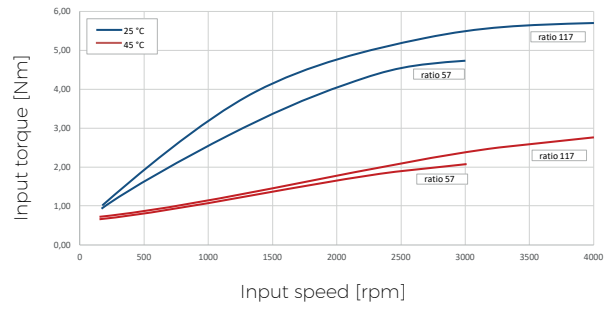


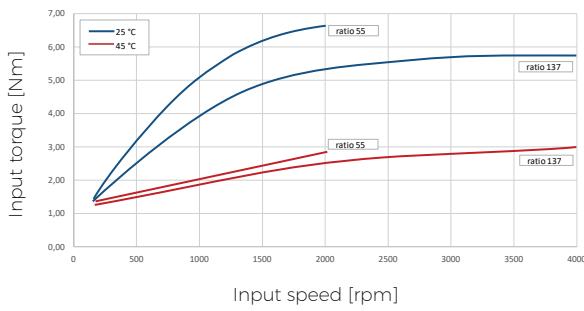
Fig. 3.15: No-load running torque charts



TS 155G, ratio 109



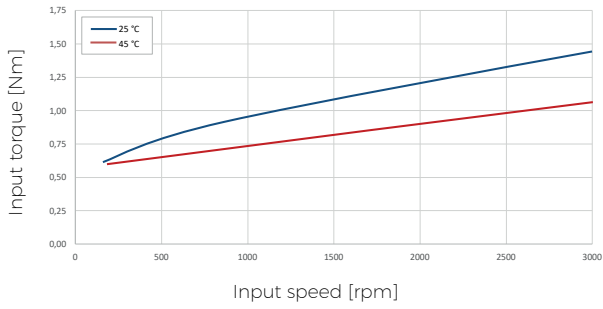
TS 185G, ratio 57, 117



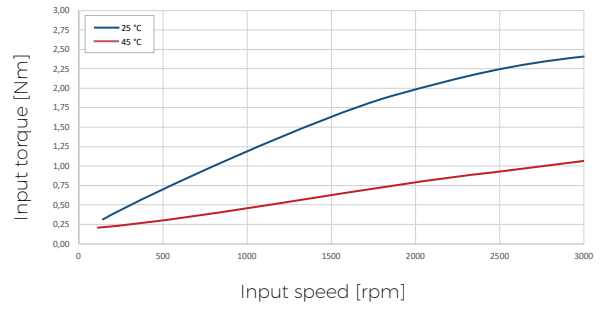
TS 225G, ratio 55, 137

Fig. 3.15: No-load running torque charts

3.16 GH series no-load running torque



TS 115GH, ratio 55, 103

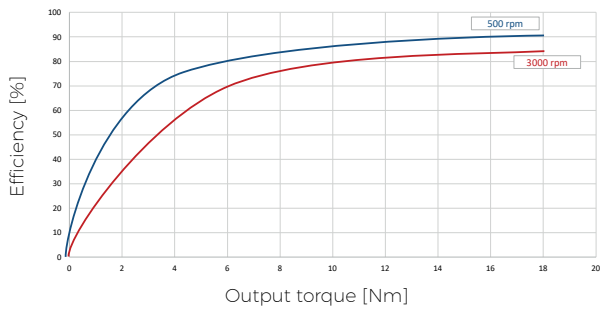


TS 125GH, ratio 49

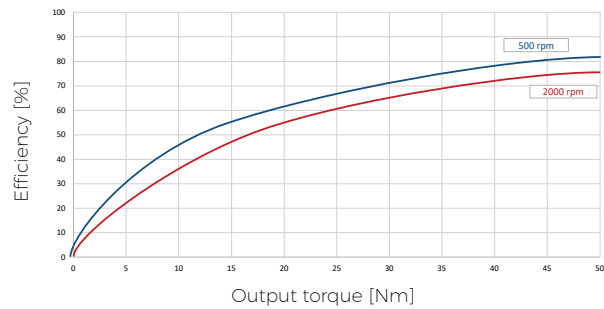
Fig. 3.16: No-load running torque charts

3.17 T, E, H, M series efficiency chart

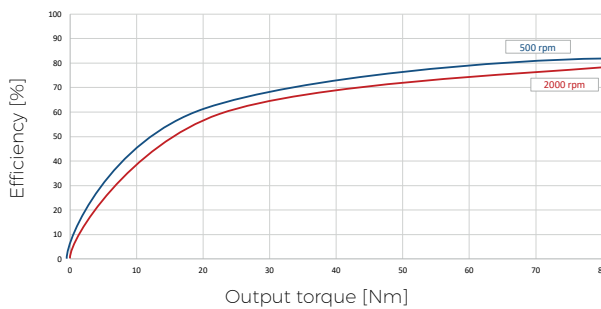
The efficiency of the TwinSpin® reduction gears depends on the input speed, output load, viscosity of lubricant, operational temperature and Lost Motion.



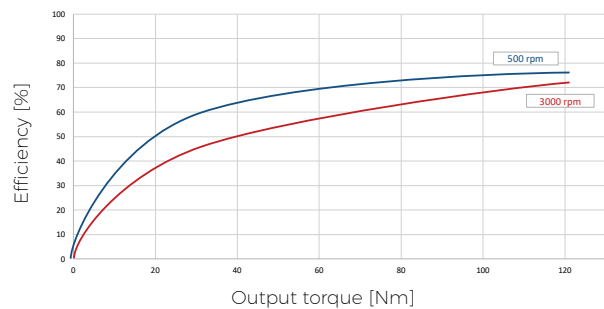
TS 50, ratio 63 at 50°C
 H = 0.7 arcmin
 LM = 0.56 arcmin
 Max. speed = 3 000 rpm



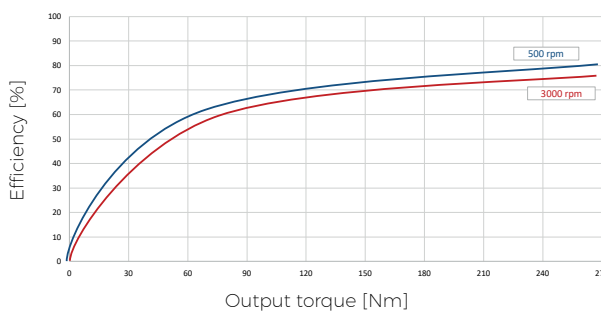
TS 70-TB, ratio 75 at 45°C
 H = 0.7 arcmin
 LM = 0.4 arcmin
 Max. speed = 3 000 rpm



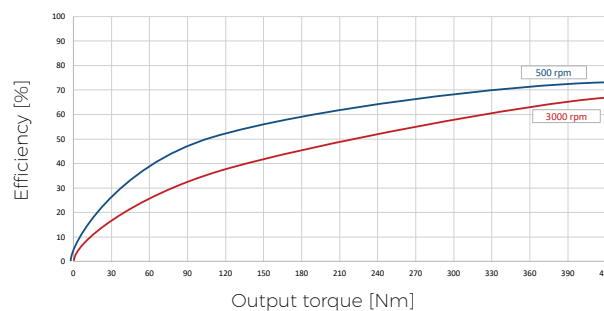
TS 80-TB, ratio 85 at 45°C
 H = 0.87 arcmin
 LM = 1 arcmin
 Max. speed = 3 000 rpm



TS 110-TB, ratio 89 at 45°C
 H = 0.43 arcmin
 LM = 0.34 arcmin
 Max. speed = 2 000 rpm

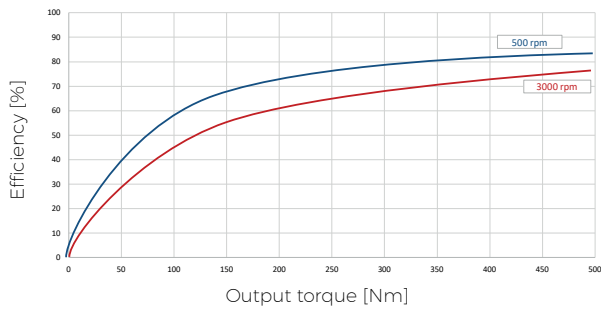


TS 140-TB, ratio 57 at 45°C
 H = 0.5 arcmin
 LM = 1 arcmin
 Max. speed = 3 000 rpm

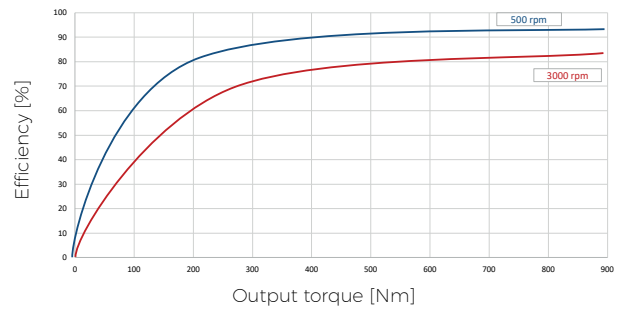


TS 170-H, ratio 69 at 60°C
 H = 0.6 arcmin
 LM = 0.5 arcmin
 Max. speed = 3 000 rpm

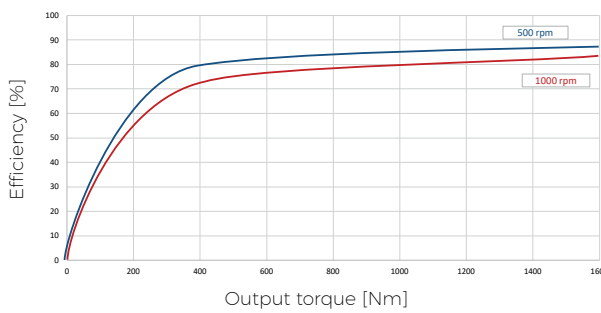
Fig. 3.17: Efficiency charts



TS 170-TC, ratio 125 at 60°C
 H = 1 arcmin
 LM = 0.85 arcmin
 Max. speed = 3 000 rpm



TS 200-TC, ratio 125 at 60°C
 H = 0.71 arcmin
 LM = 0.5 arcmin
 Max. speed = 3 000 rpm



TS 240, ratio 37 at 50°C
 H = 1 arcmin
 LM = 0.82 arcmin
 Max. speed = 1 000 rpm

Fig. 3.17: Efficiency charts

3.18 G, GH, T, E, H, M series rotation direction and reduction ratio

In the following equations, $+i_{out}$ represents input and output rotations in one direction, $-i_{out}$ represents input and output rotations in the opposite direction. The available reduction ratio "i" values are provided in the rating tables in Chapter 2.

$$i_{out} = \frac{\text{speed}_{input}}{\text{speed}_{output}}$$

Tab. 3.18: Rotation direction and reduction ratio

| | | | |
|----------------------------|--|--|--|
| Speed Reduction | | | |
| | Input: Input shaft Output: Output flange Fixed: Case $i_{out} = -i$ | Input: Input shaft Output: Case Fixed: Output flange $i_{out} = i + 1$ | Input: Output flange Output: Case Fixed: Input shaft $i_{out} = \frac{i + 1}{i}$ |
| Speed Acceleration | | | |
| | Input: Output flange Output: Input shaft Fixed: Case $i_{out} = \frac{1}{i + 1}$ | Input: Case Output: Input shaft Fixed: Output flange $i_{out} = \frac{1}{i + 1}$ | Input: Case Output: Output flange Fixed: Input shaft $i_{out} = \frac{i + 1}{i}$ |
| Differential configuration | | $\frac{1}{i + 1} = \frac{n_{case} - n_{flange}}{n_{shaft} - n_{flange}}$ | Input: |
| | All three parts can rotate | | Output: |
| | | | Fixed: |

4. TwinSpin® selection procedure

4.1 G, GH, T, E, H, M series duty cycle

- T_1 – maximum output torque at acceleration [Nm]
- T_2 – output torque at constant speed [Nm]
- T_3 – maximum output torque at deceleration [Nm]
- T_{acc} – max. acceleration / deceleration output torque [Nm]
- T_{em} – allowable emergency torque
- t_1 – acceleration time [s]
- t_2 – constant motion time [s]
- t_3 – deceleration time [s]
- t_4 – idle time [s]
- t – duty cycle time [s]
- $n_{c\ max}$ – maximum continuous input speed [rpm]
- n_1 – average input speed at acceleration [rpm]
- n_2 – input speed at constant motion [rpm]
- n_3 – average input speed at deceleration [rpm]
- n_{max} – maximum input speed [rpm]
- F_r – radial output flange load [N]
- F_{r1}, F_{r2}, F_{r3} – radial output flange load during acceleration, during constant speed and during deceleration [N]
- F_a – axial output flange load [N]
- a – radial load F_r effective arm [m]
- b – axial load F_a effective arm [m]
- i – reduction ratio

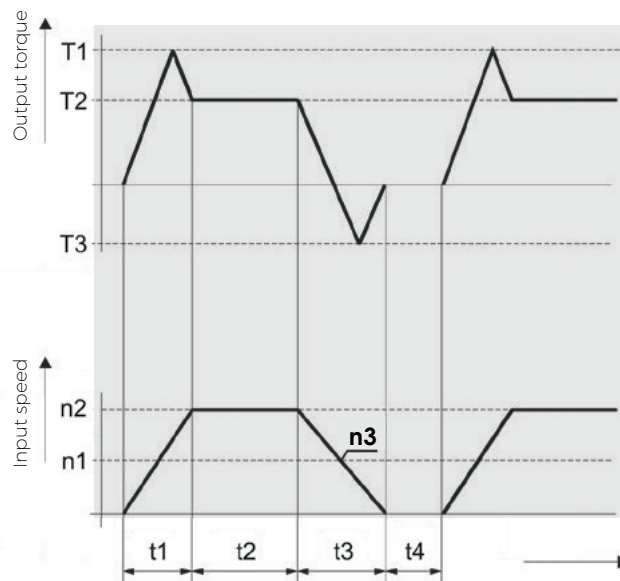


Fig. 4.1: Duty cycle

In case the duty cycle is different from the one shown, please supply the drawing and values of your duty cycle. These values are important to us to be able to effectively determine lifetimes of TwinSpin® reduction gears.

4.2 G, GH, T, E, H series selection flowchart

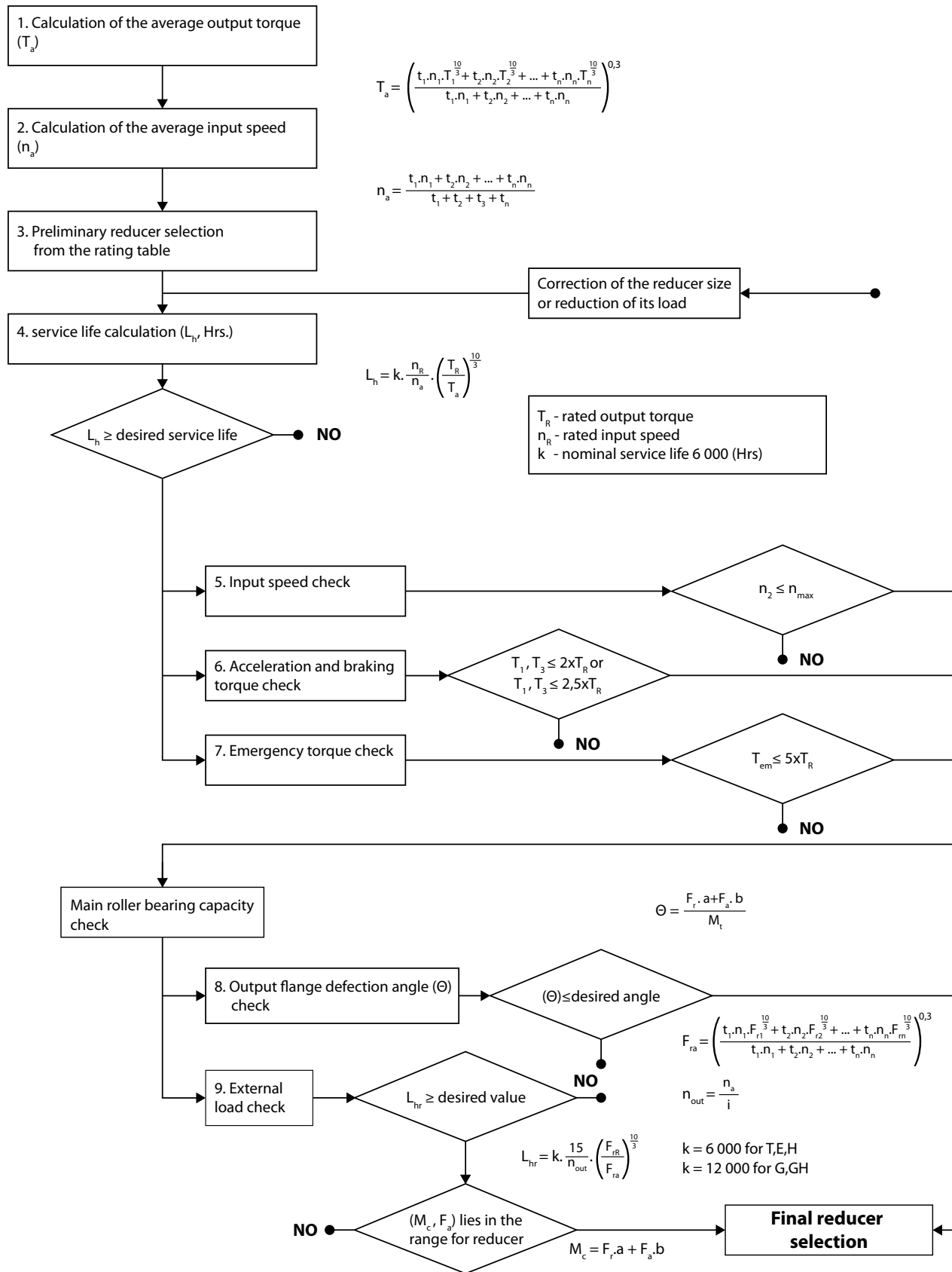


Fig. 4.2: Flowchart of the selection procedure for G, GH, T, E, H series

4.2.1 M series selection flowchart

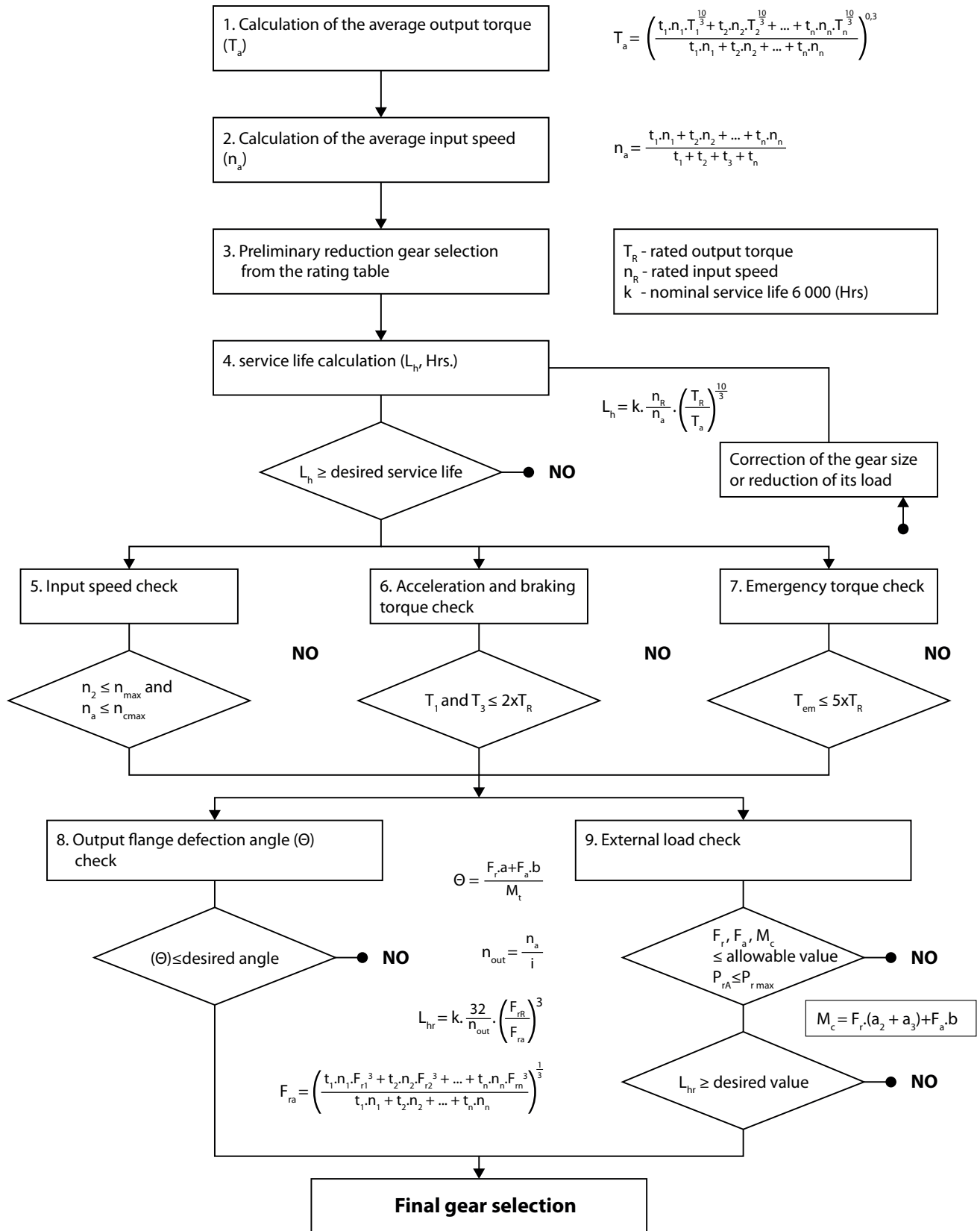


Fig. 4.2.1: Flowchart of the selection procedure for M series

4.3 T, E, H selection example

Input data - selected conditions

| | |
|------------------------------------|---|
| $T_1 = 420 \text{ Nm}$ | - Acceleration torque |
| $T_2 = 310 \text{ Nm}$ | - Constant torque |
| $T_3 = 520 \text{ Nm}$ | - Braking torque |
| $T_{em} = 1\,500 \text{ Nm}$ | - Emergency torque |
| $n_1 = 1\,500 \text{ rpm}$ | - Average acceleration input speed |
| $n_2 = 3\,000 \text{ rpm}$ | - Constant input speed |
| $n_3 = 1\,500 \text{ rpm}$ | - Average braking input speed |
| $F_r = 1\,500 \text{ N}$ | - Radial load |
| $F_a = 1\,500 \text{ N}$ | - Axial load |
| $a_2 = 0.15 \text{ m}$ | - Radial force tilting arm |
| $b = 0.2 \text{ m}$ | - Axial force tilting arm |
| $\Theta_{max} = 3 \text{ arcmin.}$ | - Max. allowable output flange deflection angle |
| $t_1 = 0.3 \text{ sec.}$ | - Acceleration time |
| $t_2 = 0.5 \text{ sec.}$ | - Constant speed time |
| $t_3 = 0.2 \text{ sec.}$ | - Braking time |

Calculation example

1. Calculation of average output torque (T_a)

$$T_a = \left(\frac{0.3 \cdot 1\,500 \cdot 420^{\frac{10}{3}} + 0.5 \cdot 3\,000 \cdot 310^{\frac{10}{3}} + 0.2 \cdot 1\,500 \cdot 520^{\frac{10}{3}}}{0.3 + 1\,500 + 0.5 \cdot 3\,000 + 0.2 \cdot 1\,500} \right)^{0.3} = 379.6 \text{ Nm}$$

2. Calculation of average input speed (n_a)

$$n_a = \frac{0.3 \cdot 1\,500 + 0.5 \cdot 3\,000 + 0.2 \cdot 1\,500}{0.3 + 0.5 + 0.2} = 2\,250 \text{ rpm}$$

3. Preliminary selection of a reduction gear from the rating table (Chapter 2): **TS 170-141-TC**

Technical specifications of the selected reduction gear:

| | |
|--------------------------------|---|
| $T_R = 495 \text{ Nm}$ | - Rated output torque |
| $n_R = 2\,000 \text{ rpm}$ | - Rated input speed |
| $T_{acc} = 1\,238 \text{ Nm}$ | - Maximum acceleration/deceleration output torque |
| $T_{em} = 2\,475 \text{ Nm}$ | - Allowable emergency torque |
| $n_{max} = 4\,000 \text{ rpm}$ | - Maximum input speed |
| $M_t = 705 \text{ Nm/arcmin.}$ | - Tilting stiffness |
| $M_{cmax} = 2\,430 \text{ Nm}$ | - Maximum tilting moment ($F_a = 0$) |
| $F_{rmax} = 19\,200 \text{ N}$ | - Maximum radial force |
| $F_{amax} = 27\,900 \text{ N}$ | - Maximum axial force ($M_c = 0$) |

4. Service life calculation (L_h)

$$L_h = 6\,000 \cdot \frac{2\,000}{2\,250} \cdot \left(\frac{495}{379.6} \right)^{\frac{10}{3}} = 12\,919 \text{ hrs}$$

5. Input speed check (n_2, n_{max})

$$n_2 = 3\,000 \text{ rpm} < n_{max} = 4\,000 \text{ rpm} \text{ ok}$$

6. Acceleration and braking torque check (T_1, T_3, T_{acc})

$$T_1 = 420 \text{ Nm} < T_{acc} = 1\,238 \text{ Nm} \quad \mathbf{ok}$$

$$T_3 = 520 \text{ Nm} < T_{acc} = 1\,238 \text{ Nm} \quad \mathbf{ok}$$

 7. Emergency braking torque check (T_{em})

$$T_{em} = 1\,500 \text{ Nm} < 2\,475 \text{ Nm} \quad \mathbf{ok}$$

 8. Output flange tilting angle check (\ominus)

$$\left(\theta = \frac{1\,500 \cdot 0.1885 + 1\,500 \cdot 0.2}{705} = \frac{582.75}{705} = 0^\circ 0' 49'' \right) < (\theta_{max} = 3') \quad \mathbf{ok}$$

 9. External load check (F_r, F_a, M_c) Tilting arm (see Fig. 3.6)

$$a = a_1 + a_2$$

$$a_1 = \frac{L}{2} = \frac{77}{2} = 38.5 \text{ mm} = 0.0385 \text{ m}$$

$$a = 0.0385 + 0.15 = 0.1885 \text{ m}$$

$$F_r = 1\,500 \text{ N} < F_{max} = 19\,300 \text{ N} \quad \mathbf{ok}$$

Service life calculation of the main bearing (L_{hr}) at radial force $F_r = 1\,500 \text{ N}$

$$n_{out} = \frac{2\,250}{141} = 15.95$$

$$L_{hr} = 6\,000 \cdot \frac{15}{15.95} \cdot \left(\frac{19\,250}{1\,500} \right)^{\frac{10}{3}} = 27.9 \cdot 10^6 \text{ hrs}$$

Moment on the output flange

$$M_c = 1\,500 \cdot 0.1885 + 1\,500 \cdot 0.2 = 582.75 \text{ Nm}$$

Maximum allowable moment at axial force $F_a = 1\,500 \text{ N}$

$$M_{c\ allow} = M_{c\ max} - \frac{M_{c\ max} \cdot F_a}{F_{a\ max}} = 2\,430 - \frac{2\,430 \cdot 1\,500}{27\,900} = 2\,300 \text{ Nm}$$

$$M_c = 582.75 < M_{c\ allow} = 2\,300 \text{ Nm} \quad \mathbf{ok}$$

Based on Chapter 3.5, a point with the coordinates of (M_c, F_a), i.e. (582.75 Nm; 1.5 kN), lies inside the range for the selected TS 170 reduction gear.

Since all the requirements have been met, selection of the TS 170-141-TC reduction gear is correct.

4.3.1 M series selection example

Input data - selection conditions

| | |
|----------------------------------|--|
| $T_1 = 15 \text{ Nm}$ | - Acceleration torque |
| $T_2 = 10 \text{ Nm}$ | - Constant torque |
| $T_3 = 14 \text{ Nm}$ | - Braking torque |
| $T_{em} = 25 \text{ Nm}$ | - Emergency torque |
| $t_1 = 0.3 \text{ sec.}$ | - Acceleration time |
| $t_2 = 0.5 \text{ sec.}$ | - Constant speed time |
| $t_3 = 0.2 \text{ sec.}$ | - Braking time |
| $n_1 = n_3 = 1\,500 \text{ rpm}$ | - Average acceleration input speed / Average braking input speed |
| $n_2 = 3\,000 \text{ rpm}$ | - Constant input speed |
| $F_r = 300 \text{ N}$ | - Radial load |
| $F_a = 400 \text{ N}$ | - Axial load |
| $a_2 = 0.012 \text{ m}$ | - Radial force tilting arm |
| $b = 0.015 \text{ m}$ | - Axial force tilting arm |
| $\Theta = 5^\circ$ | - Max. allowable output flange deflection angle |

Calculation example

1. Calculation of average output torque (T_a)

$$T_a = \left(\frac{0.3 \cdot 1\,500 \cdot 15^{\frac{10}{3}} + 0.5 \cdot 3\,000 \cdot 10^{\frac{10}{3}} + 0.2 \cdot 1\,500 \cdot 14^{\frac{10}{3}}}{0.3 \cdot 1\,500 + 0.5 \cdot 3\,000 + 0.2 \cdot 1\,500} \right)^{0.3} = 12 \text{ Nm}$$

2. Calculation of average input speed (n_a)

$$n_a = \frac{0.3 \cdot 1\,500 + 0.5 \cdot 3\,000 + 0.2 \cdot 1\,500}{0.3 + 0.5 + 0.2} = 2\,250 \text{ rpm}$$

3. Preliminary selection of a reduction gear from the rating table (Chapter 2): **TS 50-63-M-P6**

General specifications of the TwinSpin® reduction gear are:

| | |
|---|--|
| $T_R = 18 \text{ Nm}$ | - Rated output torque |
| $n_R = 2\,000 \text{ rpm}$ | - Rated input speed |
| $T_{acc} = 36 \text{ Nm}$ | - Max. acceleration/deceleration output torque |
| $T_{em} = 90 \text{ Nm}$ | - Allowable emergency torque |
| $n_{max} = 5\,000 \text{ rpm}$ | - Maximum allowable input speed |
| $n_{c,max} = 3\,000 \text{ rpm}$ | - Maximum continuous input speed |
| $M_t = 4 \text{ Nm/arcmin.}$ | - Tilting stiffness |
| $a_1 = 0.02 \text{ m}; a_2 = 0.012 \text{ m}$ | - Distance of action |
| $a = 0.02 + 0.012 = 0.032 \text{ m}$ | - Distance of action |
| $F_{r,max} = 44/(a_2 + 0.0305) \text{ N}$ | - Max. radial force |
| $F_{a,max} = 1\,900 \text{ N} (F_r = 0, M_c = 0)$ | - Max. axial force ($M_c = 0$) |

4. Calculation of the life of M series TwinSpin® reduction gear (L_h)

$$L_h = 6\,000 \cdot \frac{2\,000}{2\,250} \cdot \left(\frac{18}{12}\right)^{\frac{10}{3}} = 20\,605 \text{ hrs}$$

5. Control of input speed

$$n_2 = 3\,000 \text{ rpm} < 5\,000 \text{ rpm} \text{ and } n_a = 2\,250 \text{ rpm} < n_{c \max} = 3\,000 \text{ rpm}$$

6. Control of acceleration and braking torque

$$T_1 = 15 \text{ Nm} < 36 \text{ Nm} \text{ and } T_3 = 14 < 36 \text{ Nm}$$

7. Control of torque during emergency braking

$$T_{em} = 25 \text{ Nm} < 90 \text{ Nm}$$

8. Control of tilt angle Θ of the output flange

$$\theta = \frac{300 \cdot 0.032 + 400 \cdot 0.015}{4} = 3.9 < 5'$$

9. Control of external load on the reduction gear's output flange

$$\text{a) } F_a = 400 \text{ N} < F_{a \max} = 1\,900 \text{ N}$$

$$\begin{aligned} \text{b) } M_c &= F_a \cdot b + F_r \cdot (a_2 + a_3) \\ M_c &= 400 \cdot 0.015 + 300 \cdot (0.012 + 0.0095) = 12.45 \text{ Nm} \\ M_c &= 12.45 \text{ Nm} < M_{c \max} = 44 \text{ Nm} \end{aligned}$$

$$\begin{aligned} \text{c) } F_{r \max} &= \frac{M_{c \max}}{a_2 + 0.0305} \\ F_{r \max} &= \frac{44}{0.012 + 0.0305} \\ F_{r \max} &= 1035.3 \text{ N} \\ F_r &= 300 \text{ N} < F_{r \max} \end{aligned}$$

$$\text{d) } P_{rA} = X \cdot \left(\frac{M_c}{L_1} + F_r\right) + Y \cdot F_a$$

Calculation of coefficients X and Y according to Tab. 3.5.2b

$$\begin{aligned} \frac{R_{Ax}}{C_0} &= \frac{F_a}{C_0} \rightarrow e \\ \frac{400}{3\,850} &= 0.104 \rightarrow e = 0.30 \end{aligned}$$

$$\begin{aligned} \frac{R_{Ax}}{R_{Ay}} &= \frac{F_a}{\frac{M_c}{L_1} + F_r} \rightarrow X, Y \\ \frac{400}{\frac{12.45}{0.021} + 300} &= 0.448 > e \rightarrow X = 0.56; Y = 1.46 \end{aligned}$$

$$\begin{aligned} P_{rA} &= X \cdot \left(\frac{M_c}{L_1} + F_r\right) + Y \cdot F_a \\ P_{rA} &= 0.56 \cdot \left(\frac{12.45}{0.021} + 300\right) + 1.46 \cdot 400 \\ P_{rA} &= 1\,084 \text{ N} < P_{r \max} = 2\,100 \text{ N} \end{aligned}$$

Calculation of the life of the main bearing

$$n_{out} = \frac{2\,250}{63} = 35.71 \text{ rpm}$$
$$L_{hr} = 6\,000 \cdot \frac{32}{35.71} \cdot \left(\frac{1\,035.3}{300}\right)^3 = 220\,977 \text{ hrs}$$

Since all requirements have been met, the selection of the TS 50-63-M reduction gear is correct.

5. Assembly

5.1 G, GH, T, E, H, M series assembly manual

To get the maximum performance from the TwinSpin® high precision reduction gear, it is important to pay attention to the installation, assembly accuracy, sealing and lubrication. Most motor adapter flanges are available on request, please contact the sales department or your local sales representative for further assistance.

5.1.1 G, GH series tightening torques

For the safe transmission of external loads applied to the TwinSpin® high precision reduction gear, it is required to use connecting screws of at least 10.9 grade and to degrease contact surfaces of friction joints before the installation. Tightening torques of screws are shown in Tab. 5.1.1a.

Allowable torques transmitted through connecting screws on flange and case are shown in Tab. 5.1.1b.

Tab. 5.1.1a: Tightening torques of screws

| Screw | Tightening torque [Nm] | Clamping force [N] | Screw material class and specification |
|-------|------------------------|--------------------|--|
| M3 | 1.9 / 2.2 | 3 100 / 3 700 | 10.9 / 12.9* *10.9 / 12.9 R _m = 1 000 / 1 200 MPa - min. tensile strength of screw material R _{p0.2} = 900 / 1 080 MPa - min. yield strengths |
| M4 | 4.3 / 5.1 | 5 300 / 6 400 | |
| M5 | 8.4 / 10.2 | 8 800 / 10 600 | |
| M6 | 14 / 17 | 12 400 / 14 900 | |
| M8 | 35 / 42 | 22 750 / 27 300 | |
| M10 | 70 / 85 | 36 200 / 43 500 | |
| M12 | 122 / 147 | 52 900 / 63 500 | |

Tab. 5.1.1b: Allowable torques transmitted through connecting screws

| Size | Output flange | | | Case | | |
|----------|----------------|---------------------|-------------------------|----------------|---------------------|-------------------------|
| | Number x screw | Pitch diameter [mm] | Transmitted torque [Nm] | Number x screw | Pitch diameter [mm] | Transmitted torque [Nm] |
| TS 75 | 12xM5 | 38 | 360 | 18xM3 | 69 | 340 |
| TS 85 | 14xM5 | 44 | 490 | 18xM4 | 81 | 700 |
| TS 95 | 18xM4 | 53 | 450 | 18xM4 | 88 | 760 |
| TS 115 | 18xM5 | 68 | 970 | 18xM4 | 108 | 930 |
| TS 125 | 18xM6 | 71 | 1 190 | 18xM5 | 116 | 1 380 |
| TS 155** | 18xM8 | 96 | 2 950 | 28xM5 | 146 | 2 670 |
| TS 185** | 24xM8 | 119 | 4 870 | 30xM6 | 177 | 4 940 |
| TS 225** | 32xM8 | 150 | 8 190 | 24xM8 | 207 | 8 470 |

** Screw material 10.9

5.1.2 T series installation examples - unsealed gears

- Description of T model installations on Fig. 5.1.1 a, b, c, d:

Fig. 5.1.1 (a, b, c, d) shows examples of possible high precision reduction gear installations, their connections and sealing methods. In the case of direct connections (case a) of the reduction gear with a motor shaft, tolerances must be observed to avoid uncontrolled bending pressure and overload of the motor shaft. The tolerance values are given in Tab. 5.1.4.

Tab. 5.1.1a shows the direct method of the connection between a motor shaft and the reduction gear shaft, where the torque from the motor is transmitted through a keyway. The advantage of this connection is the short design length of the drive. This method of connection can be used if the motor shaft has a keyway and its diameter is identical with the diameter of the hole in the shaft of the reduction gear.

Fig. 5.1.1b shows the most common method of connection by using a flange with a shaft seal.

If the motor shaft does not have a keyway or its diameter is not equal to the diameter of the hole in the shaft of the reduction gear, then rigid (Fig. 5.1.1c) or flexible couplings (Tab. 5.1.1b) may be used.

A toothed pulley may be fixed with a shaft inserted into the hole of the reduction gear according to Fig. 5.1.1d, or with a reduction gear with an extended shaft.

When installing the reduction gear, please observe the dimensional tolerances of mounting diameters and prevent contamination of the reduction gear and/or leakage of the lubricant. For this purpose see Fig. 5.1.2.

Motors that meet the standard flange and keyway tolerances, as are specified in the DIN 42955 standard, are acceptable for standard applications. To make use of the overall performance and lifetime characteristics of TwinSpin® and for high precision applications, the manufacturer recommends to choose motors that comply with the DIN 42955R standard.

Please contact the sales department or your local sales representative for further details.

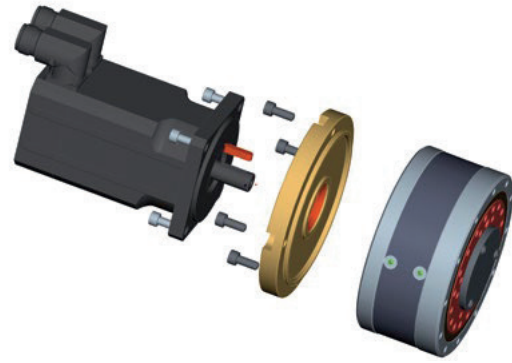
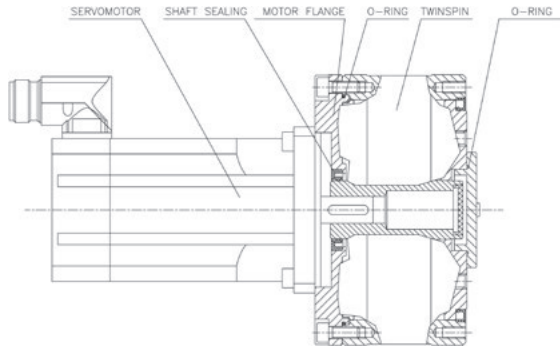


Fig. 5.1.1a:

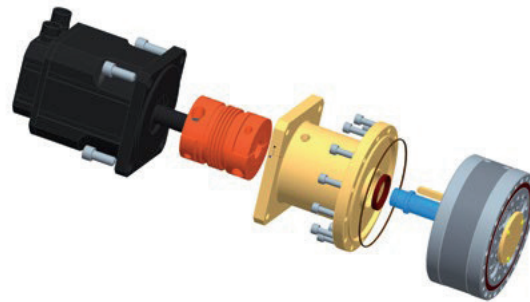
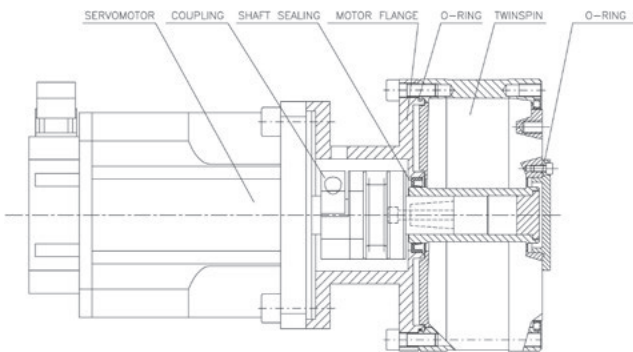


Fig. 5.1.1b:

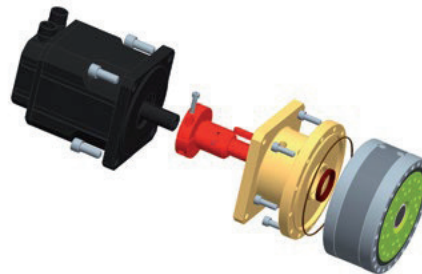
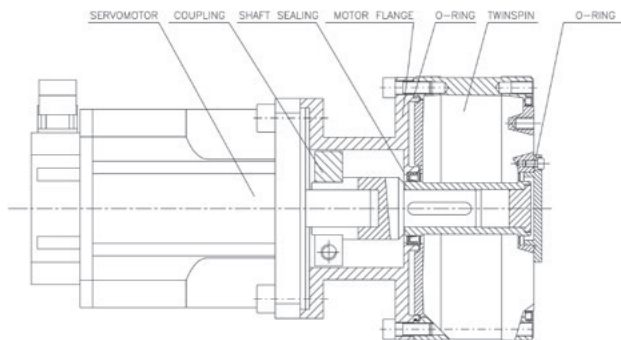


Fig. 5.1.1c:

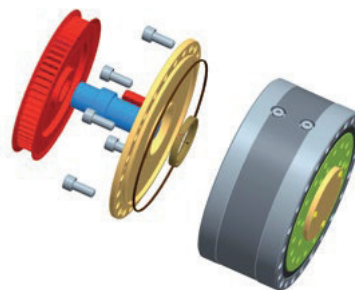
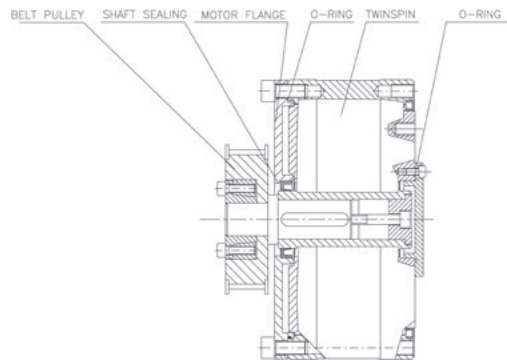


Fig. 5.1.1d:

Fig. 5.1.1: Most frequent connections

5.1.2 T series installation procedure

Prior to the installation, wipe off the protective oil film from from the reduction gear surface with a clean and dry cloth. Degrease the contact surfaces.

Please contact the sales department or your local sales representative for further information.

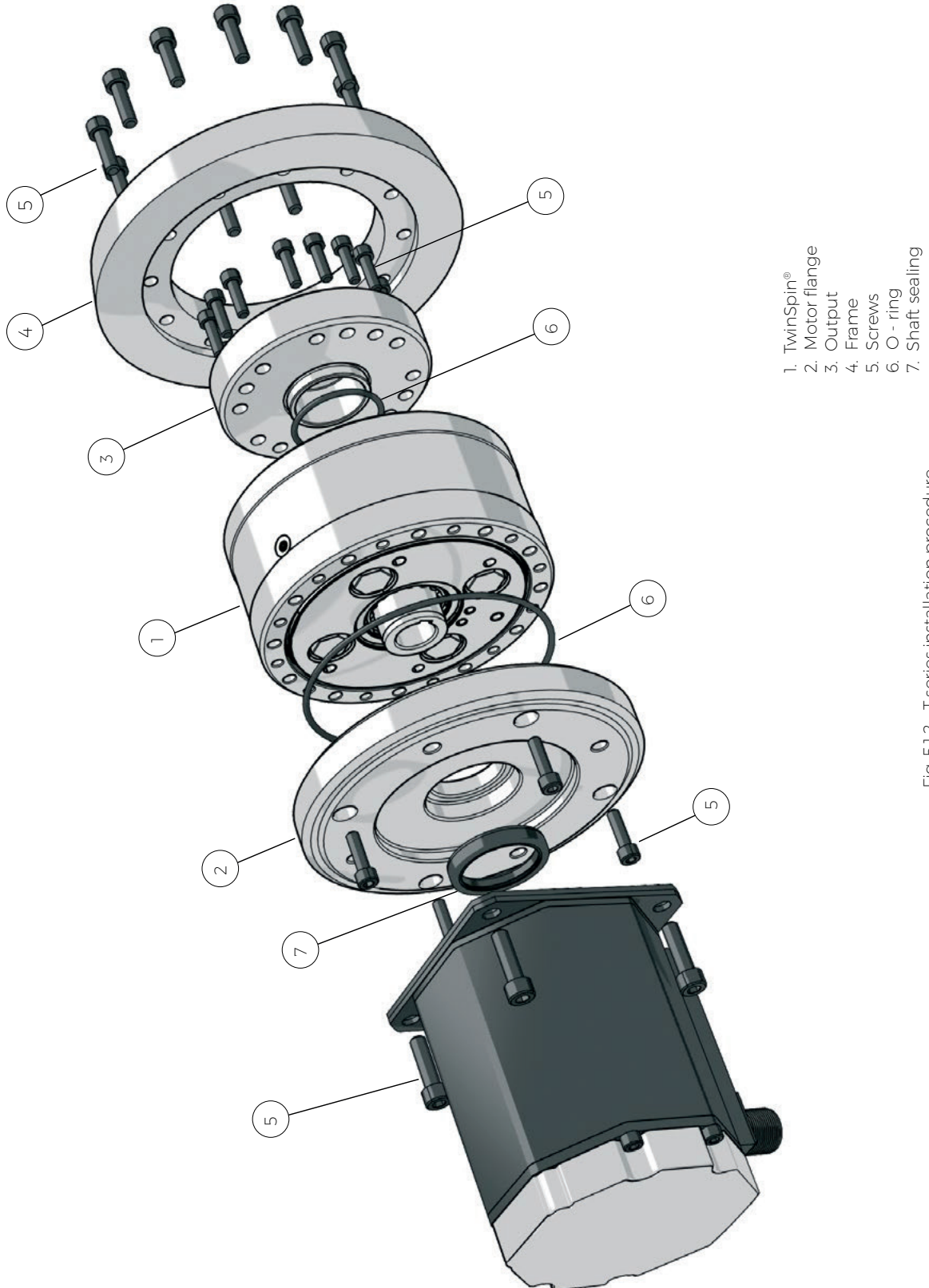


Fig. 5.1.2: T series installation procedure



5.1.3 Dimensions and tolerances of the T series connecting parts example

Tab. 5.1.3a: Dimension table of input and output flanges of the T series TwinSpin® reduction gears [in mm] Fig. 5.1.3

| Type | ØA g6 | ØB2 | ØB h9 | ØC+0.1 | ØD | ØE | ØF H8 | ØG | ØH | ØJ j6 | ØK+0.2 | ØL |
|--------|-------|-----|-------|--------|----|----|-------|-----|------|-------|--------|-----|
| TS 60 | - | 69 | 49.2 | - | - | - | - | 57 | 12.5 | 15.5 | 18 | 42 |
| TS 70 | 59.3 | - | 57.9 | 57.9 | 34 | 28 | 30 | 64 | 22 | 26 | - | 42 |
| TS 80 | - | 86 | 65 | - | - | - | - | 73 | 18 | 22.3 | 25 | 69 |
| TS 110 | 93 | - | 90 | 90 | 36 | 29 | 32 | 100 | 24 | 32 | 33 | 69 |
| TS 140 | 119 | - | 116 | 112 | 48 | 39 | 42 | 127 | 34 | 42 | 43 | 92 |
| TS 170 | 145 | - | 142 | 138 | 54 | 44 | 47 | 156 | 39 | 47 | 48 | 110 |
| TS 200 | 170 | - | 167 | 167 | 62 | 48 | 52 | 183 | 43 | 52 | 53 | 131 |
| TS 240 | - | 250 | 201.3 | - | - | - | - | 220 | 47 | 57 | 60 | 110 |
| TS 300 | - | 312 | 249.6 | - | - | - | - | 274 | 50 | 60 | 66 | 131 |

| Type | ØN | ØP H7 | ØR | ØS | ØT | A1 | A2 | A3 | A4 | B1 | B2 | B3 |
|--------|------|-------|-----|-----|------|-------|-------|-------|-------|---------|---------|---------|
| TS 60 | 4.3 | 63 | 51 | 57 | 3.2 | - | - | R 0.2 | R 0.3 | - | - | 0.5x45° |
| TS 70 | 4.3 | 70 | 58 | 64 | 3.2 | R 2 | R 0.8 | - | - | 0.3x45° | 0.3x45° | 0.3x45° |
| TS 80 | 5.3 | 80 | 65 | 73 | 4.3 | - | - | R 0.3 | R 0.3 | - | - | 0.5x45° |
| TS 110 | 6.4 | 110 | 88 | 100 | 5.3 | R 0.8 | R 0.8 | R 0.2 | - | 0.3x45° | 0.5x45° | 0.5x45° |
| TS 140 | 6.4 | 140 | 115 | 127 | 6.4 | R 0.8 | R 0.8 | R 0.2 | - | 0.5x45° | 0.5x45° | 0.5x45° |
| TS 170 | 8.4 | 170 | 140 | 156 | 8.4 | R 0.8 | R 0.8 | R 0.3 | - | 0.5x45° | 0.5x45° | 0.5x45° |
| TS 200 | 10.5 | 200 | 165 | 183 | 10.5 | R 0.8 | R 0.8 | R 0.3 | - | 0.5x45° | 0.5x45° | 0.5x45° |
| TS 240 | 13 | 240 | 201 | 220 | 12 | - | - | R 0.4 | R 0.4 | - | - | 0.5x45° |
| TS 300 | 17 | 300 | 248 | 274 | 16 | - | - | R 0.4 | R 0.4 | - | - | 0.5x45° |

| Type | C1+0.2 | C2 | C3 | E1 H12 | E2 | E3 | F2 | F3 | G1-0.1 | G2 | G3+0.05 | B3 |
|--------|--------|-----|----|--------|-----|-----|-----|-------|--------|-----|---------|---------|
| TS 60 | - | 2 | 4 | 3.2 | 1.5 | 3 | - | R 0.5 | - | 7.5 | 0.7 | 0.5x45° |
| TS 70 | 1.4 | 0.7 | 5 | 3.2 | 1.5 | 5 | 2.7 | R 0.5 | 2.8 | 5 | - | 0.3x45° |
| TS 80 | - | 1.5 | 4 | 4.3 | 1.5 | 3 | - | R 0.5 | - | 6 | 1.1 | 0.5x45° |
| TS 110 | 2 | 0.7 | 5 | 5.3 | 1.5 | 5 | 4.5 | R 0.5 | 3.5 | 6 | 0.7 | 0.5x45° |
| TS 140 | 2 | 0.7 | 5 | 6.4 | 1.5 | 5 | 2 | R 0.5 | 3.5 | 6 | 0.7 | 0.5x45° |
| TS 170 | 2 | 1 | 5 | 8.4 | 1.5 | 5 | 3.5 | R 0.5 | 3.5 | 7 | 1.1 | 0.5x45° |
| TS 200 | 2.5 | 2 | 5 | 10.5 | 1.5 | 5 | 5.5 | R 0.8 | 5.5 | 7.5 | 1.1 | 0.5x45° |
| TS 240 | - | - | 6 | 13 | 1.5 | 4.5 | - | R 0.5 | - | 7.5 | 1.5 | 0.5x45° |
| TS 300 | - | - | 6 | 17 | 1.5 | 5 | - | R 0.5 | - | 8.5 | 2.3 | 0.5x45° |

| Type | G5 | H1 | H5+0.1 | M+0.2 | V | K1. K5 | S5+0.2 | O-ring A*/ O-Ring A* | | | | |
|--------|-----|-----|--------|-------|-------|-----------|--------|----------------------|-------------|--|--|--|
| TS 60 | - | - | 0.7 | 1.4 | R 0.5 | - | 1.4 | 49x1 | Viton-FPM70 | | | |
| TS 70 | 2.8 | 5.5 | - | - | R 0.2 | 0.2 x 45° | 1.4 | 55x1 | Viton-FPM70 | | | |
| TS 80 | - | - | 0.7 | 1.4 | R 0.5 | - | 1.4 | 65x1 | Viton-FPM70 | | | |
| TS 110 | 1.5 | 6 | - | 1.4 | R 0.5 | 0.2 x 45° | - | 88.62x1.78 | Viton-FPM70 | | | |
| TS 140 | 1.5 | 3.5 | - | 1.4 | R 0.5 | 0.2 x 45° | - | 114x1.78 | Viton-FPM70 | | | |
| TS 170 | 0 | 3.5 | - | 2.1 | R 0.5 | 0.2 x 45° | - | 140x1.78 | Viton-FPM70 | | | |
| TS 200 | 2.5 | 8 | - | 2.1 | R 0.5 | 0.2 x 45° | - | 165x2 | Viton-FPM70 | | | |
| TS 240 | - | - | 1.1 | 2.8 | R 0.5 | - | 2.1 | 201.5x1.5 | Viton-FPM70 | | | |
| TS 300 | - | - | 1.5 | 3.9 | R 0.5 | - | 2.8 | 250x2 | Viton-FPM70 | | | |

| Type | O-ring B* | | Double lip oil sealing | | | |
|--------|-----------|-------------|------------------------|-----------|---------|-----------|
| | | | "A" | | "B" | |
| TS 60 | 18x1 | Viton-FPM70 | 11x22x6 | FPM 70 | - | - |
| TS 70 | - | Viton-FPM70 | 20x30x5 | 75FKM 595 | - | - |
| TS 80 | 26x1.5 | Viton-FPM70 | 15x30x7 | 75FKM 595 | - | - |
| TS 110 | 33.5x1 | Viton-FPM70 | 22x32x6 | 75FKM 595 | 22x32x6 | 75FKM 595 |
| TS 140 | 43x1 | Viton-FPM70 | 30x42x6 | 75FKM 595 | 30x42x6 | 75FKM 595 |
| TS 170 | 48x1.5 | Viton-FPM70 | 35x47x7 | 75FKM 595 | 35x47x7 | 75FKM 595 |
| TS 200 | 54x1.5 | Viton-FPM70 | 38x52x7 | 75FKM 595 | 38x52x7 | 75FKM 595 |
| TS 240 | 60x2 | Viton-FPM70 | 40x55x7 | 75FKM 595 | - | - |
| TS 300 | 66x3 | Viton-FPM70 | 42x55x8 | 75FKM 595 | - | - |

Note:

Dimensions and technical parameters of the sealings need to be observed according to the data contained in the table. Possible changes should be discussed with the manufacturer.

Fig. 5.1.1 (a, b, c, d) shows examples of possible high precision reduction gear installations, their connections and sealing methods.

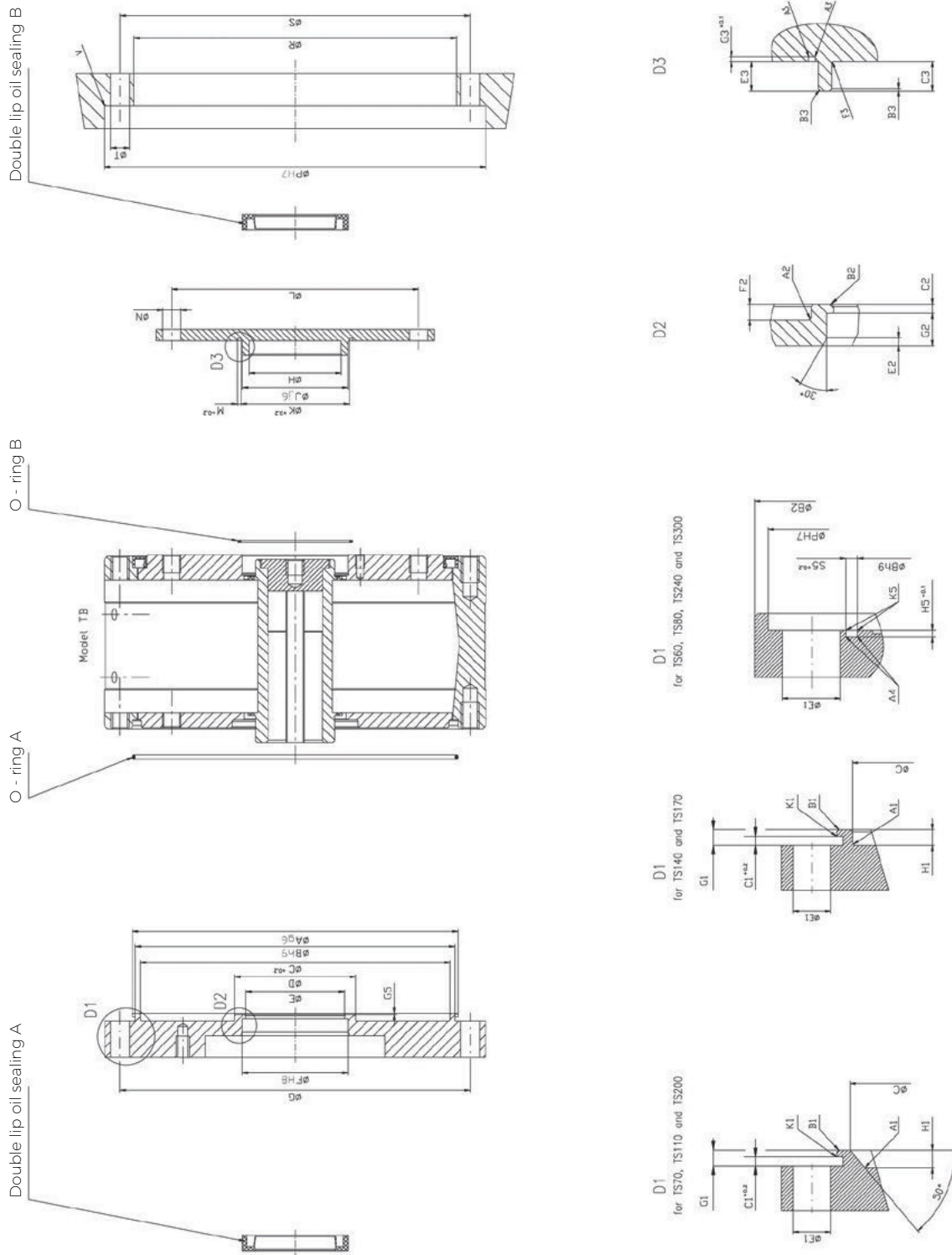


Fig. 5.1.3: Dimensions of input and output flanges of the TwinSpin® T series reduction gear

5.1.4 T series connecting parts tolerances

According to the DIN 42955 R standard

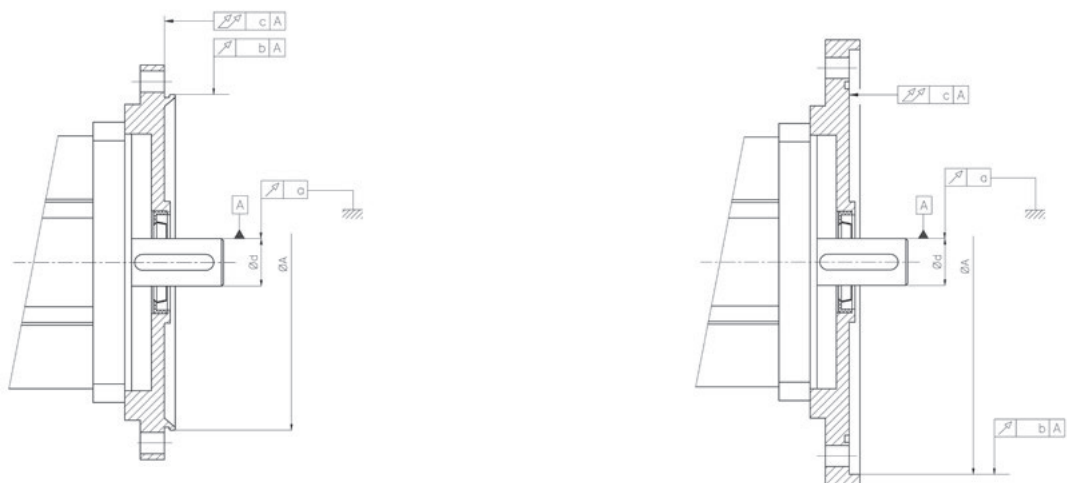


Fig. 5.1.4: Required tolerances of the T series
 a) valid for TS 70, TS 110, TS 140, TS 170, TS 200
 b) valid for TS 60, TS 80, TS 240, TS 300

Tab. 5.1.4: T series - required tolerances [mm]

| Size | a | b | c | Ød | ØA |
|--------|-------|-------|-------|-------|---------|
| TS 60 | 0.015 | 0.040 | 0.038 | 6 k6 | 63 H7 |
| TS 70 | 0.018 | 0.040 | 0.038 | 11 k6 | 59.3 G6 |
| TS 80 | 0.015 | 0.050 | 0.038 | 8 k6 | 80 H7 |
| TS 110 | 0.018 | 0.050 | 0.044 | 14 k6 | 93 G6 |
| TS 140 | 0.021 | 0.050 | 0.050 | 19 k6 | 119 G6 |
| TS 170 | 0.021 | 0.050 | 0.050 | 24 k6 | 145 G6 |
| TS 200 | 0.021 | 0.060 | 0.058 | 24 k6 | 170 G6 |
| TS 240 | 0.021 | 0.063 | 0.058 | 28 k6 | 240 H7 |
| TS 300 | 0.021 | 0.063 | 0.064 | 28 k6 | 300 H7 |

5.1.5 T series circumferential and face run-out values

Tab. 5.1.5: T series - circumferential and face runout values [mm]

| Type | T | Z | R | A | C | D | Π | T2 |
|--------|-------|-------|-------|--------|---------|-------|------|------|
| TS 60 | 0.007 | 0.020 | 0.015 | 63 h7 | 15.5 H6 | 6 H7 | 0.05 | 0.05 |
| TS 70 | 0.007 | 0.020 | 0.015 | 70 h7 | 26 H6 | 11 H7 | 0.05 | 0.05 |
| TS 80 | 0.007 | 0.020 | 0.015 | 80 h7 | 22.3 H6 | 8 H7 | 0.06 | 0.05 |
| TS 110 | 0.008 | 0.025 | 0.015 | 110 h7 | 32 H6 | 14 H7 | 0.07 | 0.06 |
| TS 140 | 0.009 | 0.025 | 0.015 | 140 h7 | 42 H6 | 19 H7 | 0.07 | 0.06 |
| TS 170 | 0.010 | 0.025 | 0.015 | 170 h7 | 47 H6 | 24 H7 | 0.07 | 0.06 |
| TS 200 | 0.010 | 0.035 | 0.020 | 200 h7 | 52 H6 | 24 H7 | 0.08 | 0.06 |
| TS 240 | 0.013 | 0.040 | 0.020 | 240 h7 | 57 H6 | 28 H7 | 0.08 | 0.06 |
| TS 300 | 0.013 | 0.040 | 0.020 | 300 h7 | 60 H6 | 28 H7 | 0.08 | 0.06 |

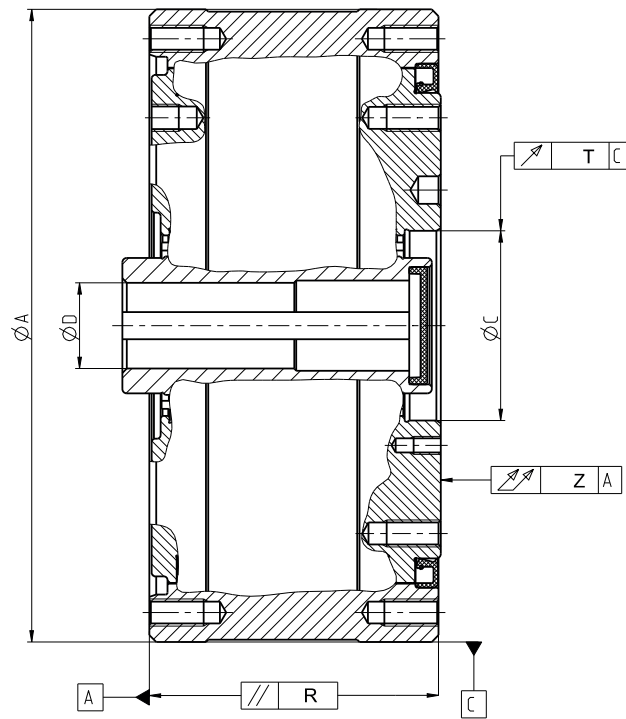


Fig. 5.1.5a: Tolerances of circumferential and face runout for direct connection of TwinSpin® high precision reduction gears with a servomotor in accordance with DIN 42955 R

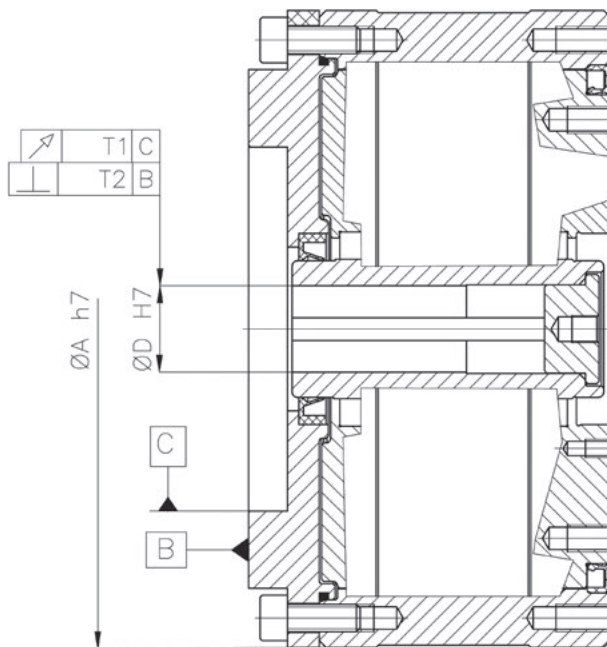


Fig. 5.1.5b: Circumferential and face runout values of the TwinSpin® T series

5.1.6 T series tightening torques

For the safe transmission of external loads applied to the TwinSpin® high precision reduction gear, it is required to use connecting screws of at least 10.9 grade and to degrease contact surfaces of friction joints before the installation. Tightening torques of screws are shown in Tab. 5.1.6a.

Allowable torques transmitted through connecting screws on flange and case are shown in Tab. 5.1.6b.

Tab. 5.1.6a: Tightening torques of screws

| Screw | Tightening torque [Nm] | Clamping force [N] | Screw material class and specification |
|-------|------------------------|--------------------|--|
| M3 | 1.9 | 3 100 | ISO 898 T1 10.9 or 12.9 |
| M4 | 4.3 | 5 300 | |
| M5 | 8.4 | 8 800 | |
| M6 | 14 | 12 400 | |
| M8 | 35 | 22 750 | |
| M10 | 70 | 36 200 | |
| M12 | 122 | 52 900 | |

Tab. 5.1.6b: Allowable torques transmitted through connecting screws

| Size | Output flange | | | Case | | |
|--------|----------------|---------------------|-------------------------|----------------|---------------------|-------------------------|
| | Number x screw | Pitch diameter [mm] | Transmitted torque [Nm] | Number x screw | Pitch diameter [mm] | Transmitted torque [Nm] |
| TS 60 | 8xM4 | 34 | 108 | 12xM3 | 57 | 160 |
| TS 70 | 14xM4 | 42 | 233 | 16xM3 | 64 | 238 |
| TS 80 | 8xM5 | 46 | 242 | 12xM4 | 73 | 348 |
| TS 110 | 14xM6 | 69 | 898 | 12xM5 | 100 | 792 |
| TS 140 | 14xM6 | 92 | 1 740 | 12xM6 | 127 | 1 410 |
| | 8xM6 | 74 | | | | |
| TS 170 | 14xM8 | 110 | 3 700 | 12xM8 | 156 | 3 200 |
| | 8xM8 | 80 | | | | |
| TS 200 | 14xM10 | 131 | 6 950 | 12xM10 | 183 | 5 900 |
| | 8xM10 | 95 | | | | |
| TS 240 | 14xM12 | 160 | 8 800 | 12xM12 | 220 | 10 400 |
| TS 300 | 14xM16 | 200 | 21 000 | 12xM16 | 274 | 24 600 |

5.2 E series installation examples

5.2.1 E series installation examples - unsealed gears

Description of the E series installation:

Fig. 5.2.1a It is possible to use a direct connection of the TwinSpin® reduction gear with a motor, if the motor shaft has the same diameter as the hole in the reduction gear.

Fig. 5.2.1b It is possible to use a connection of two different shafts by flexible couplings, if the shafts have different diameters.

Fig. 5.2.1c Mounting of a toothed pulley on the input shaft of the TwinSpin® reduction gear.

Fig. 5.2.1 shows examples of TwinSpin® reduction gear installations, connections and sealing methods. In the case of direct connections of the reduction gear with a motor shaft, tolerances must be observed to avoid uncontrolled bending pressure and overload of the motor shaft. Tolerance values are shown in Tab. 5.2.3. When installing TwinSpin® reduction gears, observe dimensional tolerances of mounting diameters and avoid contamination of the high precision reduction gear and/or leakage of the lubricant.

Motors that meet the standard flange and keyway tolerances, as specified in the European DIN 42955 standard, are acceptable for standard use. In order to make use of the overall performance and durability of TwinSpin® and for high precision applications, the manufacturer recommends to choose motors that meet the European DIN 42955 R standard. Our sales department will be happy to provide you with additional information on the standards or technical assistance for your specific applications. Please contact the sales department or your local sales representative.

Examples of drive connection with the input shaft

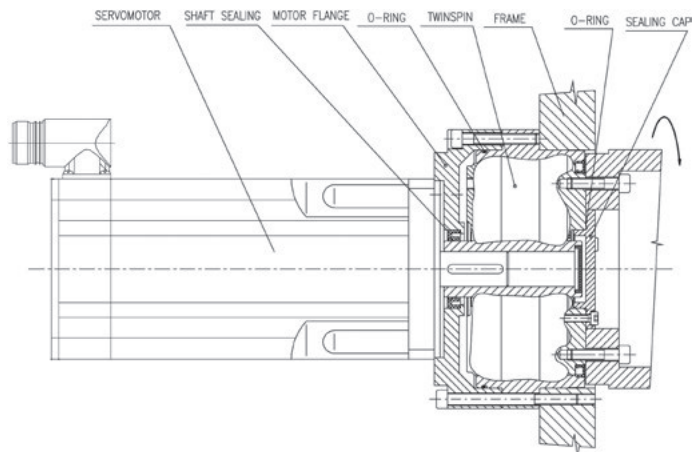


Fig. 5.2.1a: Direct connection of the reduction gear shaft with the motor shaft

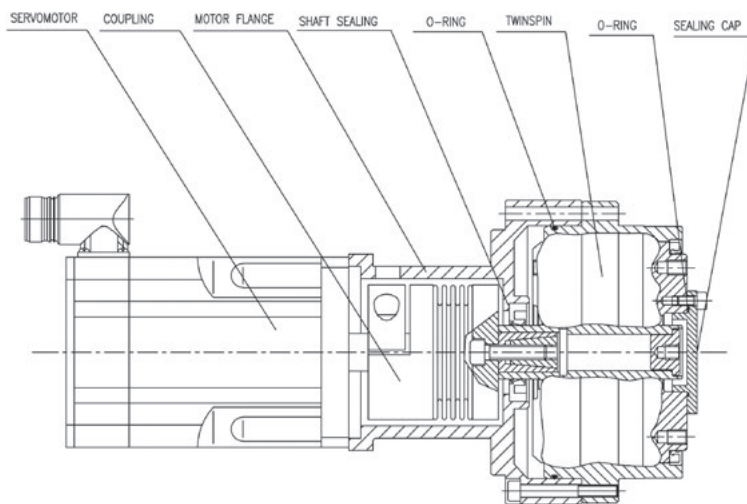
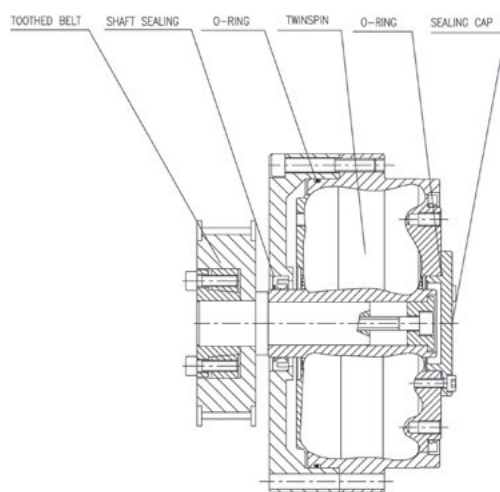


Fig. 5.2.1b: Connection of the motor with the reduction gear with a flexible coupling



Note: The sealing cap is used only with reduction gears TS 110, TS 140, TS 220

Fig. 5.2.1c: Connection of the reduction gear with a toothed pulley

Fig. 5.2.1: Most frequent connections

5.2.2 E series installation procedure

Prior to the installation, wipe off the protective oil film from the reduction gear's surface with a clean and dry cloth. TwinSpin® high precision reduction gears are not protected against corrosion. Please contact the sales department or your local sales representative for further information.

5.2.3 E series connecting parts dimensions and tolerances

Tab. 5.2.3: Dimensional data of the TwinSpin® high precision reduction gear input flange – E series [mm]

| Type | ∅ D H7 | ∅ D1 | ∅ D2 | ∅ D3 | ∅ D4 | ∅ D5 | ∅ D6 H8 | H1 | H2 |
|--------|--------|------|------|-------|------|------|---------|------|-----|
| TS 70 | 67 | 85 | 76 | 56 | 36 | 26 | 30 | 11,5 | 6,5 |
| TS 80 | 75 | 95 | 85 | 60 | 38 | 28 | 32 | 14,5 | 7,5 |
| TS 110 | 103 | 123 | 113 | 89 | 46 | 36 | 40 | 19 | 7 |
| TS 140 | 128 | 150 | 140 | 111,5 | 50 | 38 | 42 | 15 | 8 |
| TS 170 | 160 | 190 | 175 | 139 | 65 | 46 | 50 | 23 | 11 |
| TS 200 | 186 | 225 | 206 | 176 | 66 | 46 | 52 | 30 | 5 |
| TS 220 | 198 | 238 | 220 | 178 | - | 46 | 52 | 30 | 10 |

| Type | H3 | H4 | H5 | Kx30° | L | L1 | L2 | 2xM1 |
|--------|-----|-----|-----|--------|------|-----|----|------|
| TS 70 | 2,5 | 2,5 | 6,5 | 1x30 | 14,5 | 4,5 | 6 | M4 |
| TS 80 | 2,5 | 2 | 8,5 | 1x30 | 16,5 | 5 | 8 | M5 |
| TS 110 | 2,5 | 2,5 | 8 | 1,5x30 | 21 | 5,5 | 10 | M5 |
| TS 140 | 5 | 2,5 | 9 | 1,5x30 | 21 | 6 | 10 | M6 |
| TS 170 | 7,5 | 2,5 | 9 | 2x30 | 24 | 5,5 | 12 | M8 |
| TS 200 | 0 | 3 | 9 | 2x30 | 27 | 6 | 12 | M10 |
| TS 220 | 0 | 3 | 9 | 2x30 | 32 | 8 | 12 | M8 |

| Type | M2, M3, M4 | n x ∅N | R1° | R2° | R3° | R4° | n x S1 | 4 x S2 |
|--------|------------|--------|-----|-----|-----|-----|---------|--------|
| TS 70 | M4 | 3x10 | 30 | 12 | 15 | -15 | 8x∅5,5 | 4x∅5,5 |
| TS 80 | M5 | 2x10 | 48 | 15 | - | 15 | 10x∅5,5 | 4x∅5,5 |
| TS 110 | M6 | 3x11 | 40 | 10 | 20 | 20 | 12x∅5,5 | 4x∅5,5 |
| TS 140 | M10x1 | 3x15 | 40 | 10 | 20 | 10 | 12x∅6,5 | 4x∅5,5 |
| TS 170 | M10x1 | 3x15 | 40 | 10 | 20 | 10 | 12x∅9 | 4x∅8,4 |
| TS 200 | M10x1 | 3x15 | 40 | 15 | 15 | 15 | 12x∅11 | 4x∅8,4 |
| TS 220 | M10x1 | 2x15 | 40 | - | 20 | 20 | 12x∅11 | 4x∅11 |

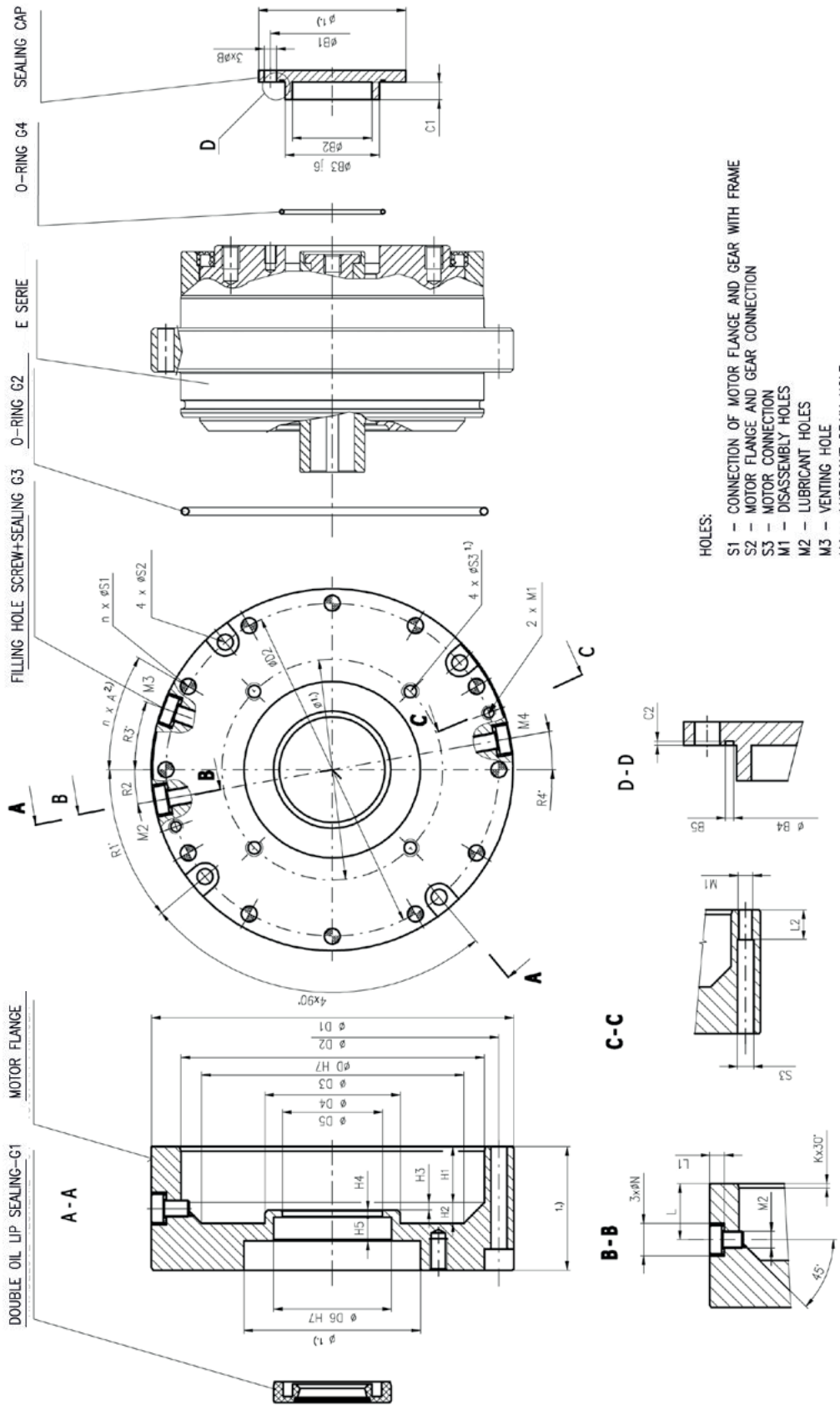
| Type | Seal G1 (FPM 70) | O-ring G2 (FPM 70) | Plug | | Flat sealing G3 (DIN 7603 (cuprum)) |
|--------|------------------|--------------------|---------|----------|-------------------------------------|
| TS 70 | 20 x 30 x 5 | 62 x 2 | M4 x 8 | DIN 7984 | 4 x 8 x 1 |
| TS 80 | 16 x 32 x 7 | 70 x 2 | M 5 x 8 | DIN 7984 | 5 x 9 x 1 |
| TS 110 | 22 x 40 x 7 | 95 x 2 | M6 x10 | DIN 7984 | 6 x 10 x 1 |
| TS 140 | 30 x 42 x 6 | 122 x 2 | M10x1 | DIN 908 | 10 x 14 x 1,5 |
| TS 170 | 36 x 50 x 7 | 150 x 2 | M10x1 | DIN 908 | 10 x 14 x 1,5 |
| TS 200 | 38 x 52 x 7 | 175 x 2 | M10x1 | DIN 908 | 10 x 14 x 1,5 |
| TS 220 | 38 x 52 x 7 | 195 x 2 | M10x1 | DIN 908 | 10 x 14 x 1,5 |

| Type | n x ∅ B | ∅ B1 | ∅ B2 | ∅ B3 j6 | ∅ B4 | B5 + 0.2 | C1 | C2+0.05 | O-ring G4 |
|--------|---------|------|------|---------|------|----------|-----|---------|-----------|
| TS 110 | 3 x 4,3 | 42 | 27 | 32 | 33 | 1,4 | 6 | 0,7 | 33 x 1 |
| TS 140 | 3 x 4,3 | 53 | 36 | 42 | 43 | 1,4 | 6,5 | 0,7 | 43 x 1 |
| TS 220 | 3 x 5,3 | 75 | 69 | 110 | - | - | 4 | - | 110 x 3 |

| Type | ∅ D H7 | ∅ D1 | ∅ D2 | ∅ D3 | ∅ D4 | ∅ D5 | ∅ D6 H8 | H1 | H2 |
|--------|--------|------|------|-------|------|------|---------|------|-----|
| TS 70 | 67 | 85 | 76 | 56 | 36 | 26 | 30 | 11,5 | 6,5 |
| TS 80 | 75 | 95 | 85 | 60 | 38 | 28 | 32 | 14,5 | 7,5 |
| TS 110 | 103 | 123 | 113 | 89 | 46 | 36 | 40 | 19 | 7 |
| TS 140 | 128 | 150 | 140 | 111,5 | 50 | 38 | 42 | 15 | 8 |
| TS 170 | 160 | 190 | 175 | 139 | 65 | 46 | 50 | 23 | 11 |
| TS 200 | 186 | 225 | 206 | 176 | 66 | 46 | 52 | 30 | 5 |
| TS 220 | 198 | 238 | 220 | 178 | - | 46 | 52 | 30 | 10 |

Note:

The output flange of TwinSpin® high precision reduction gears TS 70-E, TS 80-E, TS 170-E and TS 200-E is sealed as a standard. No additional sealing cap is needed.



- **1)** CUSTOMIZED DIMENSIONS
- **2)** PITCH DIAMETER ACCORDING GEAR SIZE
- **3)** SIZES TS110, TS140 AND TS220 MUST BE SEALED.
- RESPECT DIMENSIONAL TOLERANCES

Dimensions and tolerances of the E series connecting components

5.2.4 E series mounting tolerances

The requirements for circumferential and face runout in the case of a direct connection of the high precision reduction gear with a servomotor with a shaft in accordance with DIN 42955R are specified in Fig. 5.2.4a. The tolerances are specified in Tab. 5.2.4

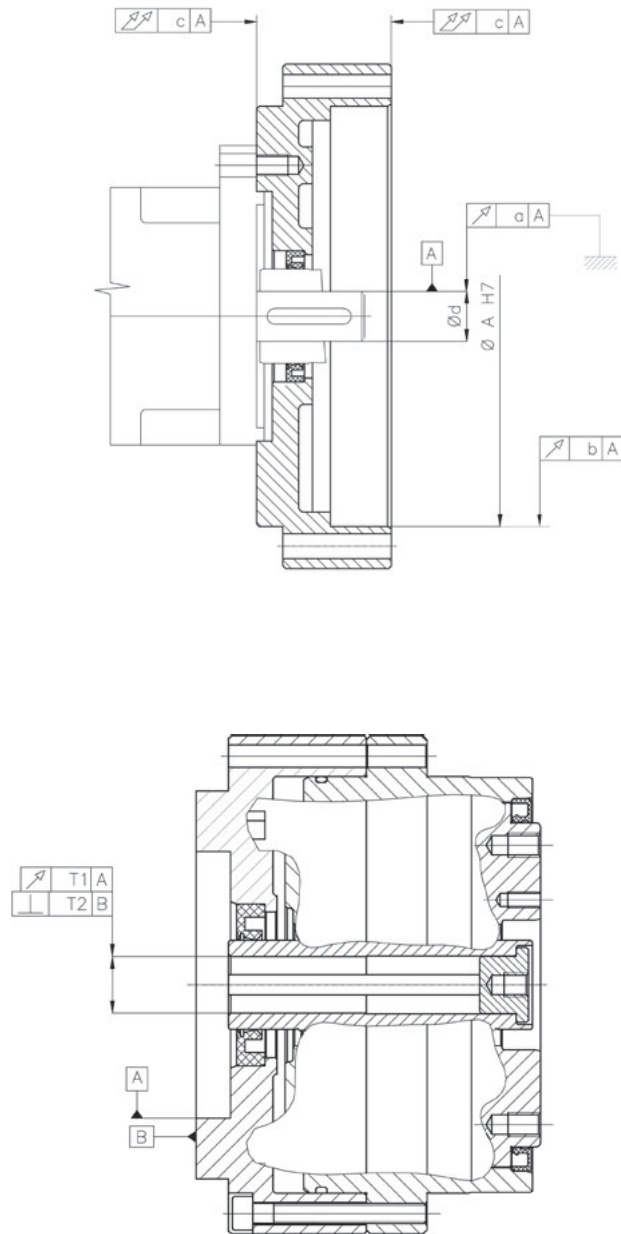


Fig. 5.2.4a: Geometric deviations for the connection of the E series TwinSpin® high precision reduction gear flange with a motor or of the TwinSpin® E series reduction gear

Tab. 5.2.4: Tolerances of circumferential and face runout in the case of a direct connection of TwinSpin® high precision reduction gears with a servomotor according to DIN 42955 R [mm]

| Type | a | b | C | T1 | T2 | U | T | Z | V |
|--------|-------|-------|-------|------|------|-------|-------|-------|-------|
| TS 70 | 0,015 | 0,04 | 0,038 | 0,05 | 0,05 | 0,010 | 0,007 | 0,020 | 0,025 |
| TS 80 | 0,015 | 0,05 | 0,038 | 0,06 | 0,05 | 0,010 | 0,007 | 0,020 | 0,025 |
| TS 110 | 0,018 | 0,05 | 0,044 | 0,07 | 0,06 | 0,010 | 0,008 | 0,025 | 0,025 |
| TS 140 | 0,021 | 0,05 | 0,05 | 0,07 | 0,06 | 0,010 | 0,009 | 0,025 | 0,030 |
| TS 170 | 0,021 | 0,05 | 0,05 | 0,07 | 0,06 | 0,015 | 0,010 | 0,025 | 0,030 |
| TS 200 | 0,025 | 0,05 | 0,058 | 0,07 | 0,06 | 0,015 | 0,010 | 0,035 | 0,030 |
| TS 220 | 0,025 | 0,063 | 0,058 | 0,08 | 0,06 | 0,015 | 0,013 | 0,030 | 0,035 |

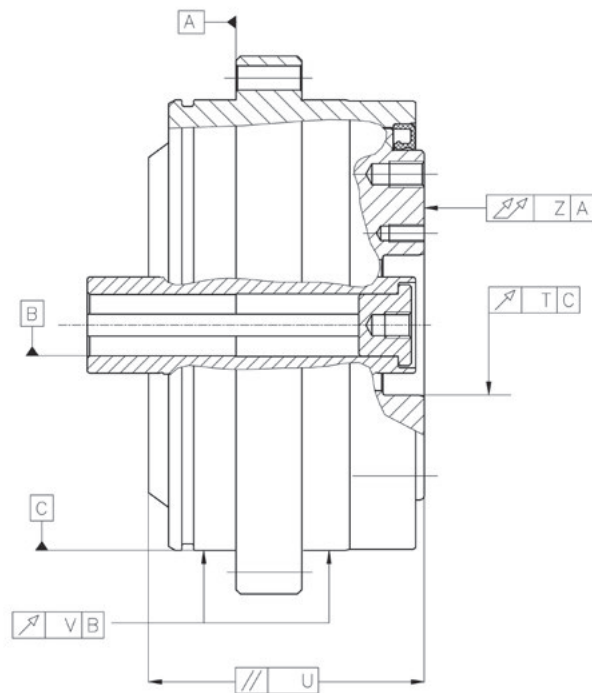


Fig. 5.2.4b: Tolerances of circumferential and face runout in the case of direct connection of TwinSpin® high precision reduction gears with a servomotor according to DIN 42955 R

5.2.5 E series tightening torques of connecting bolts

For the safe transmission of external loads applying on the TwinSpin® high precision reduction gear, it is required to use connecting screws of at least 10.9 grade and to degrease contact surfaces of friction joints before installation. Tightening torques of the screws are shown in Tab. 5.2.5b.

Allowable torque transmitted through the connecting screws on the flange and case are shown in Tab. 5.2.5b.

Tab. 5.2.5a: Tightening torques of screws

| Screw | Tightening torque [Nm] | Clamping force [N] | Screw material class specification |
|-------|------------------------|--------------------|------------------------------------|
| M3 | 1.9 | 3 100 | ISO 898 T1 10.9 or 12.9 |
| M4 | 4.3 | 5 300 | |
| M5 | 8.4 | 8 800 | |
| M6 | 14 | 12 400 | |
| M8 | 35 | 22 750 | |
| M10 | 70 | 36 200 | |
| M12 | 122 | 52 900 | |
| M16 | 300 | 100 000 | |
| M18 | 455 | 120 000 | |

Tab. 5.2.5b: Allowable torques transmitted through connecting screws

| Size | Output flange | | | Case | | |
|--------|----------------|---------------------|-------------------------|----------------|---------------------|-------------------------|
| | Number x screw | Pitch diameter [mm] | Transmitted torque [Nm] | Number x screw | Pitch diameter [mm] | Transmitted torque [Nm] |
| TS 70 | 5xM6 | 40 | 186* | 10xM5 | 76 | 500 |
| TS 70 | 5xM6 | 40 | 254* | 10xM5 | 76 | 500 |
| | with pin Ø6 | 40 | | | | |
| TS 80 | 8xM5 | 46 | 242* | 10xM5 | 85 | 560 |
| TS 110 | 14xM6 | 69 | 890 | 14xM5 | 113 | 1 040 |
| TS 140 | 18xM6 | 92 | 2090 | 12xM6 | 140 | 1 560 |
| | 8xM6 | 74 | | | | |
| TS 170 | 18xM8 | 110 | 4470 | 14xM8 | 175 | 4 180 |
| | 8xM8 | 80 | | | | |
| TS 200 | 18xM12 | 129 | 9880 | 14xM10 | 206 | 7 830 |
| | 8xM6 | 91 | | | | |
| TS 220 | 20xM10 | 140 | 7600 | 14xM10 | 220 | 8 350 |

* Safe transmission of the the torque requires glue to be applied on the friction surfaces (NICRO 20-10, NICRO 32-02; LOCTITE 603)

5.3 H series installation examples

5.3.1 H series mounting examples

The H series is completely sealed and filled with grease for its lifetime. Fig. 5.3.1a, Fig. 5.3.1b and Fig. 5.3.1c show examples of connections with motors.

The through input shaft of the H series high precision reduction gear with an enlarged diameter allows to pass energy supply or control cables through the axis of the reduction gear to devices mounted behind the output flange. The H series reduction gear is most often used in combination with a pre-stage, which may comprise gears or toothed belt drives. A typical example of the H series reduction gear drive through a toothed belt is shown in Fig. 5.3.1a. The driven pulley is attached to the shaft of the reduction gear with screws, which have to be tightened with a tightening torque according to Tab. 5.3.4a and Tab. 5.3.4b. The driving pulley with the motor must be shiftable to allow the tightening of the belt.

Fig. 5.3.1b shows the drive of the input shaft through gears. The gears are housed in a frame, which is part of the reduction gear input flange.

Fig. 5.3.1c shows a toothed pulley mounted on the input flange by means of friction rings.

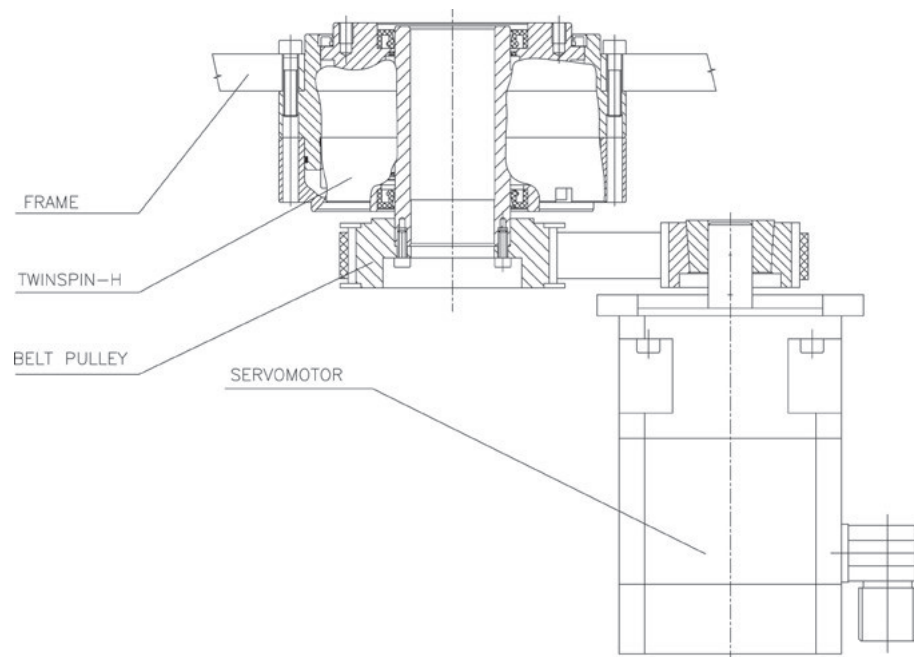


Fig. 5.3.1a: Connection of a toothed pulley with the reduction gear shaft by means of a screw connection

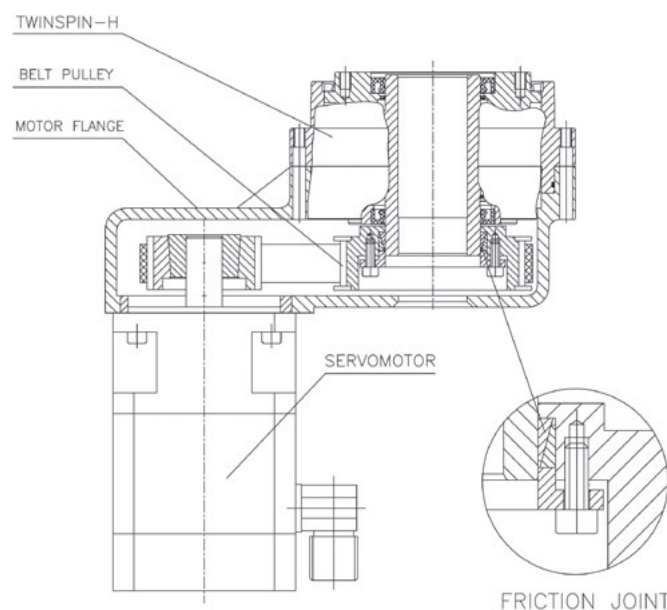


Fig. 5.3.1b: Connection of a toothed pulley with the reduction gear shaft by means of a friction connection

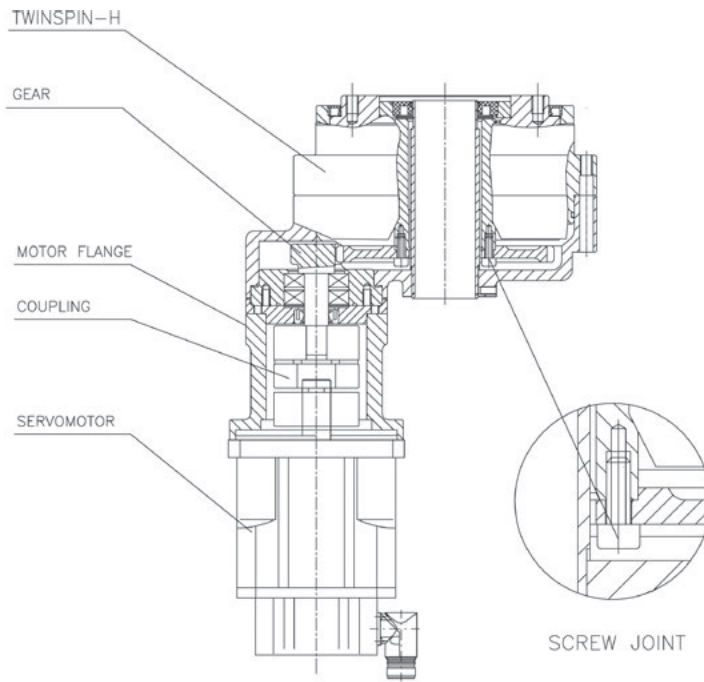


Fig. 5.3.1c: Connection of a gear wheel with the reduction gear shaft by means of a screw connection

5.3.2 H series installation procedure

Prior to the installation, wipe off the protective oil film from the reduction gear's surface with a clean and dry cloth. Degrease the contact surfaces of the friction-type of connections. TwinSpin® high precision reduction gears are not protected against corrosion. Please, contact the sales department or your local sales representative for further information.

5.3.3 H series mounting tolerances

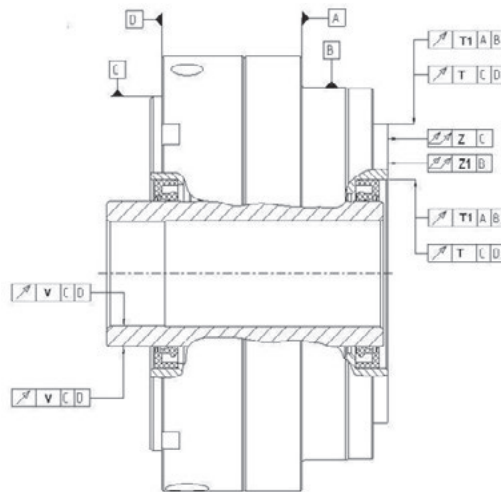


Fig. 5.3.3: Maximum geometric deviations for the H series reduction gear

Tab. 5.3.3a: Maximum geometric deviations for the H series reduction gear [mm]

| | TS 140H | TS 170H | TS 200H | TS 220H |
|----|---------|---------|---------|---------|
| T | 0,02 | 0,02 | 0,02 | 0,02 |
| T1 | 0,013 | 0,015 | 0,015 | 0,015 |
| Z | 0,025 | 0,025 | 0,03 | 0,03 |
| Z1 | 0,015 | 0,015 | 0,02 | 0,02 |
| V | 0,05 | 0,05 | 0,06 | 0,06 |

5.3.4 H connecting screws tightening torques

For the safe transmission of external loads applied to the TwinSpin® high precision reduction gear, it is required to use connecting screws of at least 10.9 grade and to degrease contact surfaces of friction joints before the installation. Tightening torques of screws are shown in Tab. 5.3.4a. Allowable torques transmitted through connecting screws on the flange and case are shown in Tab. 5.3.4b.

Tab. 5.3.4a: Tightening torques of screws

| Screw | Tightening torque [Nm] | Clamping force [N] | Screw material class specification |
|-------|------------------------|--------------------|------------------------------------|
| M3 | 1.9 | 3 100 | ISO 898 T1 10.9 or 12.9 |
| M4 | 4.3 | 5 300 | |
| M5 | 8.4 | 8 800 | |
| M6 | 14 | 12 400 | |
| M8 | 35 | 22 750 | |
| M10 | 70 | 36 200 | |
| M12 | 122 | 52 900 | |
| M16 | 300 | 100 000 | |
| M18 | 455 | 120 000 | |

Tab. 5.3.4b: Allowable torques transmitted through connecting screws

| Size | Output flange | | | Case | | |
|--------|----------------|---------------------|-------------------------|----------------|---------------------|-------------------------|
| | Number x screw | Pitch diameter [mm] | Transmitted torque [Nm] | Number x screw | Pitch diameter [mm] | Transmitted torque [Nm] |
| TS 70 | 5xM6 | 40 | 186* | 8xM5 | 76 | 400 |
| TS 70 | 5xM6 | 40 | 254* | 8xM5 | 76 | 400 |
| | with pin Ø6 | 40 | | | | |
| TS 140 | 16xM6 | 92 | 1 400 | 12xM6 | 140 | 1 560 |
| TS 170 | 18xM8 | 110 | 3 300 | 12xM8 | 175 | 3 580 |
| TS 200 | 18xM12 | 131 | 6 400 | 12xM10 | 206 | 6 700 |
| TS220 | 20xM10 | 140 | 7 600 | 12xM10 | 220 | 7 100 |

* Safe transmission of the the torque requires glue to be applied on the friction surfaces (NICRO 20-10, NICRO 32-02; LOCTITE 603)

5.4 M series installation examples

In order to achieve the maximum performance of the TwinSpin® high precision reduction gear, it is important to pay attention to the installation and accuracy of the assembly and lubrication. The M series high precision reduction gears are completely sealed. The modular design of the reduction gear allows the connection of different drive parts. Motor flanges and shaft couplings are required for this connection. We can design and supply such parts upon request together with a reduction gear.

5.4.1 M series installation examples

The most common cases of connections between the M series TwinSpin® high precision reduction gear and a servomotor are shown on Fig. 5.4.1a, Fig. 5.4.1b, Fig. 5.4.1c, and Fig. 5.4.1d. Direct connection of the shaft of the high precision reduction gear with a motor through a keyway. This connection requires that the motor shaft has the same diameter as the hole in the high precision reduction gear. In the case of direct connection of the reduction gear with a motor, all specified tolerances for the coupling flange must be met and only motors with shafts that meet the tolerances specified in the European DIN 42955 standard may be used. Our sales department will provide you with information on such standards or will provide technical assistance for your specific application.

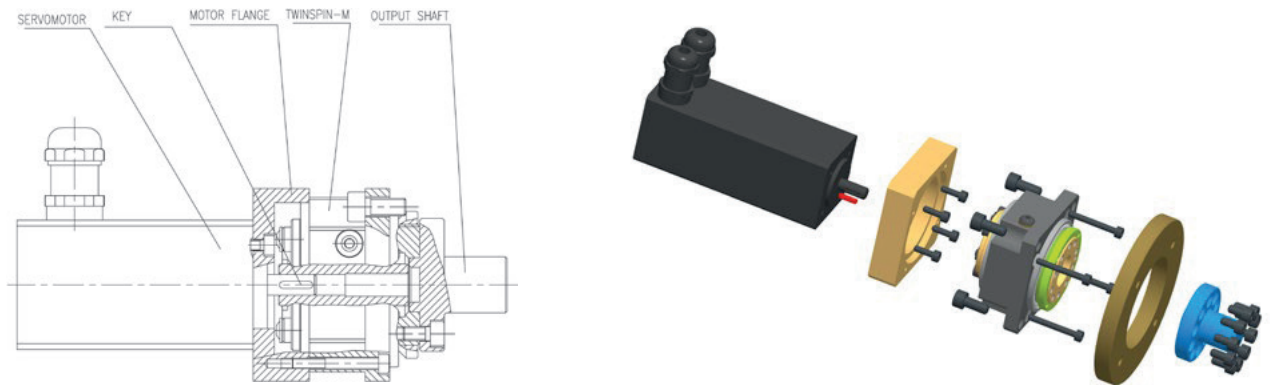


Fig. 5.4.1a: Shaft connection with a keyway

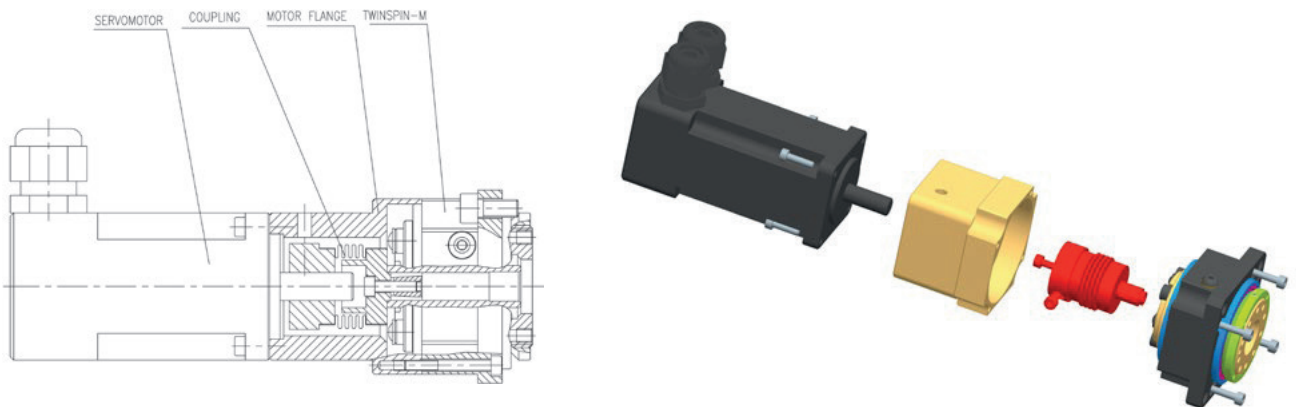


Fig. 5.4.1b: Shaft connection with a flexible coupling

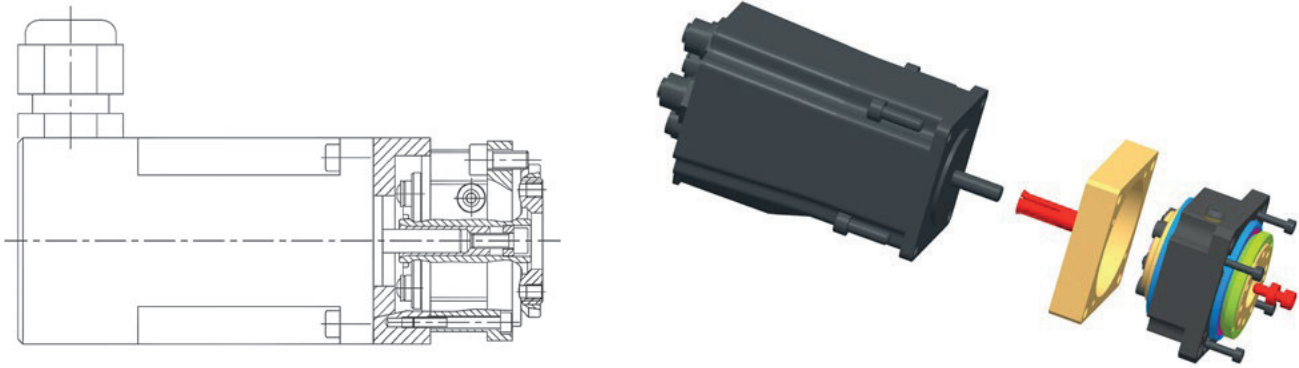


Fig. 5.4.1c: Shaft connection with a collet

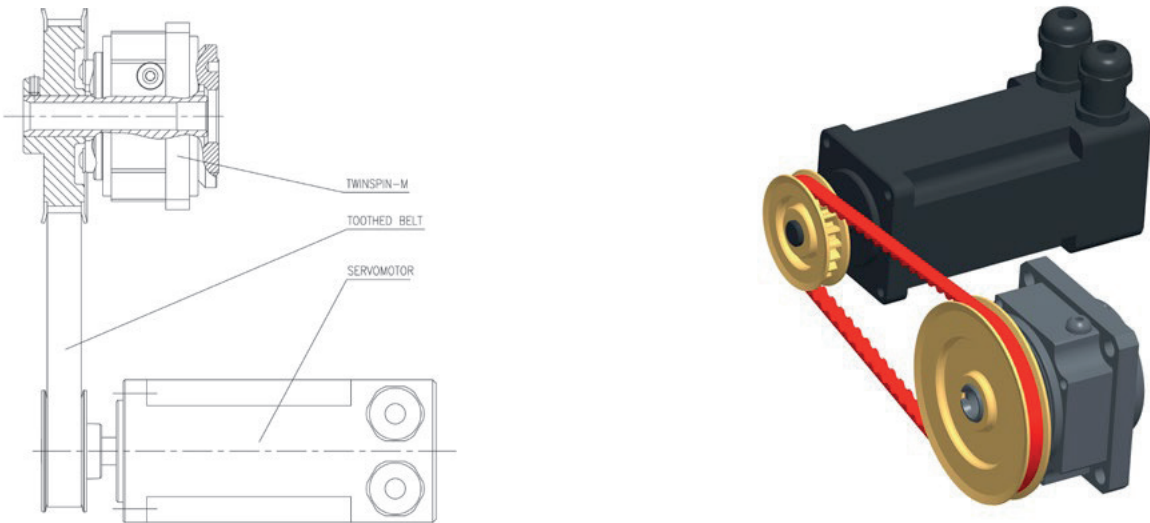


Fig. 5.4.1d: Example of the use of the hollow-shaft version of the reduction gear, driven through a toothed belt

5.4.2 M series installation procedure

A typical example of an assembly with TS 50 is shown on Fig. 5.4.2 Before the installation, it is desirable to wipe off the protective oil film from the surface of the reduction gear with a clean and dry cloth. Contact surfaces of friction joints must be degreased prior to the installation. When cleaning, make sure that the degreaser does not get into the reduction gear. During the installation, proceed with the following steps: first, fasten a coupling to the reduction gear, then the connecting motor flange to which the motor needs to be mounted and afterwards bolt the whole assembly to the frame.

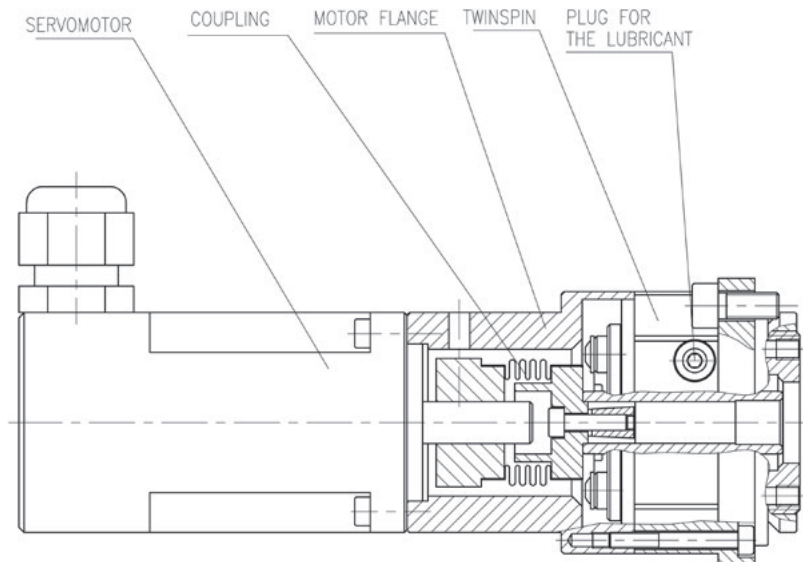


Fig. 5.4.2: Typical connection of a motor to the M series reduction gear

5.4.3 M series connecting parts tolerances

| Tab. 5.4.3: Maximum geometric deviations for the M series reduction gear [mm] | |
|---|-------|
| Tolerance | TS 50 |
| a | 0.02 |
| b | 0.04 |
| c | 0.038 |
| d | 6 j6 |
| A | 47 H7 |

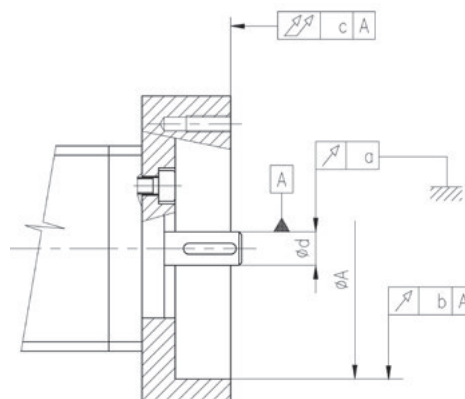


Fig. 5.4.3: Tolerances of M series connecting parts

5.4.4 M series connecting parts geometrical deviations

| Tab. 5.4.4: M series reduction gear [mm] | |
|--|-------|
| Tolerance | TS 50 |
| T | 0.01 |
| Z | 0.02 |
| ϕD H7 | 6.0 |
| ϕC H7 | 15.5 |
| ϕA h6 | 47.0 |

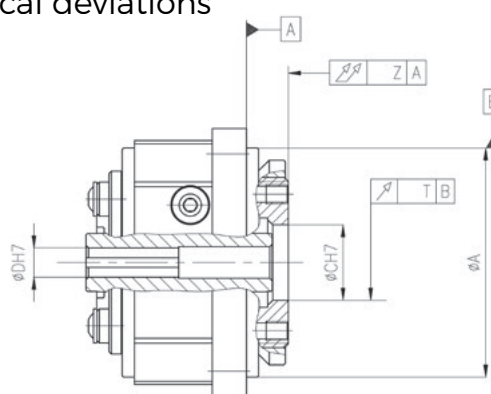


Fig. 5.4.4: Radial and axial runout of the output flange

5.4.5 M series connecting screws tightening torque

For the safe transmission of external loads applied to the TwinSpin® high precision reduction gear, it is required to use connecting screws of at least 10.9 grade and to degrease contact surfaces of friction joints before the installation. Tightening torques of screws are shown in Tab. 5.4.5a. Allowable torques transmitted through connecting screws on the flange and case are shown in Tab. 5.4.5b

Tab. 5.4.5a: Tightening torques of screws

| Screw | Tightening torque [Nm] | Clamping force [N] | Screw material class specification |
|-------|------------------------|--------------------|------------------------------------|
| M3 | 1.9 | 3 100 | ISO 898 T1 10.9 or 12.9 |
| M4 | 4.3 | 5 300 | |
| M5 | 8.4 | 8 800 | |
| M6 | 14 | 12 400 | |
| M8 | 35 | 22 750 | |

Tab. 5.4.5b: Allowable torques transmitted through connecting screws

| Size | Output flange | | | Case | | |
|-------|----------------|---------------------|-------------------------|----------------|---------------------|-------------------------|
| | Number x screw | Pitch diameter [mm] | Transmitted torque [Nm] | Number x screw | Pitch diameter [mm] | Transmitted torque [Nm] |
| TS 50 | 10xM4 | 28 | 110 | 4xM5 | 63 | 165 |



5.5 Lubrication, cooling, preheating

The TwinSpin® reduction gear is lubricated as a standard with the Castrol TRIBOL GR 100-0 PD or TRIBOL GR TT 1 PD grease. Alternatively, the Castrol OPTIGEAR 150 oil may be used. More information is available on www.castrol.com. It is forbidden to mix the lubricant used for the lubrication of the reduction gear with other types of lubricants. The lubricant change interval highly depends on the individual operating conditions.

Grease and oil quantities for individual TwinSpin® reduction gears are specified in Tab. 5.5.a. These quantities, however, do not include the space between the reduction gear and the connected parts. If no rotary shaft seal is used, the user must fill it with the lubricant. The change interval of the lubricant inside the reduction gear depends mainly on the actual operating conditions and duty cycle.

High temperatures and high speeds and loading will reduce the service life of the lubricant. In many cases re-lubrication will not be necessary because the reduction gear is filled for a long life. The recommended interval for lubricant change is 20 000 operating hours.

T series - is not a completely sealed series of high precision reduction gears, however, this series is normally filled with grease Castrol TRIBOL GR 100-0 PD or TRIBOL GR TT 1 PD. The recommended amount of grease for each size of T series reduction gears is shown in Tab. 5.5.a. These figures, however, do not include the space between the TwinSpin® reduction gear and sealing flanges. The user secures complete sealing and addition of the lubricant to the free space. It is recommended to fill up to 70 - 80 % of the free sealed volume. On the basis of a request by the user, SPINEA can offer a complete sealed and grease-filled solution.

E series - is not a completely sealed series of high precision reduction gears, normally filled with oil Castrol OPTIGEAR or Castrol TRIBOL GR 100-0 PD or TRIBOL GR. The user will fill the reduction gear with grease after its complete sealing. It is recommended to fill up to 70 - 80 % of the free sealed volume.

H series - is a completely sealed series of high precision reduction gears, normally filled with grease CASTROL TRIBOL GR TT 1 PD.

M series - is a completely sealed series of high precision reduction gears, normally filled with grease CASTROL TRIBOL GR TT 1 PD.

Tab. 5.5.a: Recommended lubricant quantities for the filling of the T, E, H, M series [cm³]

| Size | Volume of the lubricant |
|--------|-------------------------|
| TS 50 | M series - 3 |
| TS 60 | T series - 5 |
| TS 70 | T, E, H series - 10 |
| TS 80 | T, E series - 15 |
| TS 110 | T, E, H series - 30 |
| TS 140 | T, E series - 70 |
| TS 140 | H series - 75 |
| TS 170 | T, E series - 120 |
| TS 170 | H series - 270 |
| TS 200 | T, E series - 180 |
| TS 200 | H series - 345 |
| TS 220 | E series - 200 |
| TS 220 | H series - 350 |
| TS 240 | T series - 300 |
| TS 300 | T series - 470 |

Note:

*The specified values represent 80 % filling of the internal volume of the T series TwinSpin® high precision reduction gears. In the case of accessories of the reduction gear manufactured by the user, it is necessary to increase these values by the amount that represents 80 % of the space between the reduction gear and the accessories. Lubrication levels in the horizontal and vertical positions are on Tab. 5.5.a.

**If other types of seals instead of rotary shaft seals are used on the reduction gear, or in the case of desired leakage of grease from the reduction gear, it is required from the customer to prescribe greasing intervals at his own risk or to consult the supplier for the confirmation of the warranty period.

When the reduction gear is in operation, the temperature of the lubricant should not exceed the maximum temperature defined by the lubricant manufacturer. Otherwise it is necessary to take into consideration the possible loss of lubricating properties of the used lubricant.

Tab. 5.5.b: Recommended lubricant quantities for the filling of the G series [cm³]

| Size | Volume of the lubricant |
|--------|-------------------------|
| TS 75 | G series - 10 |
| TS 85 | G series - 20 |
| TS 95 | G series - 30 |
| TS 115 | G series - 40 |
| TS 125 | G series - 40 |
| TS 135 | G series - 65 |
| TS 155 | G series - 130 |
| TS 185 | G series - 230 |
| TS 225 | G series - 300 |

Tab. 5.5.c: Range of use and lifetime of lubricants

| Lubricant | Type | Range of use |
|----------------------------|--------|------------------|
| Castrol TRIBOL GR 100-0 PD | Grease | -35 °C – +140 °C |
| Castrol TRIBOL GR TT 1 PD | Grease | -60 °C – +120 °C |
| Castrol OPTIGEAR 150 | Oil | -10 °C – +90 °C |

When these limits are exceeded, it is necessary to provide cooling or pre-heating of the reduction gears. In such cases please contact our sales department.

Attention: The temperatures stated in Tab. 5.5.c are the temperatures stated by the manufacturer for the determination of the lubricant lifetime in certain extreme conditions of its use, for the determination of re-lubrication intervals or its change. These temperatures are not identical with the temperatures inside or on the surface of the reduction gear. Since the thermal conditions inside the reduction gear and on its surface are less extreme in standard operation than the limit temperatures for the lubricant, the lifetime of the lubricant filling is higher than it is stated in the table.

Cooling

Cooling of the reduction gears is not necessary in most cases. But there are some cases when the temperature on the reduction gear surface becomes a limiting factor for a given duty cycle and relative ambient temperature. The reduction gear warming-up in extreme duty cycles should not be higher than by 40 °C of the ambient temperature of 20 °C - 25 °C.

Cooling is usually used in the following cases:

- special regulations applicable for explosive environments where a low temperature is requested
- ambient temperature higher than 40 °C
- heat transmission between the electric motor and the reduction gear is too high

For the reason of the preservation of the proper functioning of the reduction gear (lubricant, sealing, pre-stress degree and material dilatation) during the guaranteed lifetime, the limit temperature expresses the limit temperature of the reduction gear, measured on its surface.

Tab. 5.5.d: Limit temperature of the reduction gear surface (measured on the gear surface)

| Lubricant | Reduction gear limit temperature | |
|----------------------------|----------------------------------|-----------------|
| | TS 50 - TS 140 | TS 170 - TS 300 |
| Castrol TRIBOL GR 100-0 PD | 65 °C | 70 °C |
| Castrol TRIBOL GR TT 1 PD | 65 °C | 70 °C |
| Castrol OPTIGEAR 150 | 65 °C | 70 °C |

The stated temperatures represent a condition, when the reduction gear is not overloaded by speed with regard to lost motion. If the temperature is higher despite static (increasing of the surface for the heat dissipation) or dynamic (forced) cooling, it is necessary to decrease the speed or to use a reduction gear with higher LM (lost motion).

In such cases please contact our sales department for technical support.

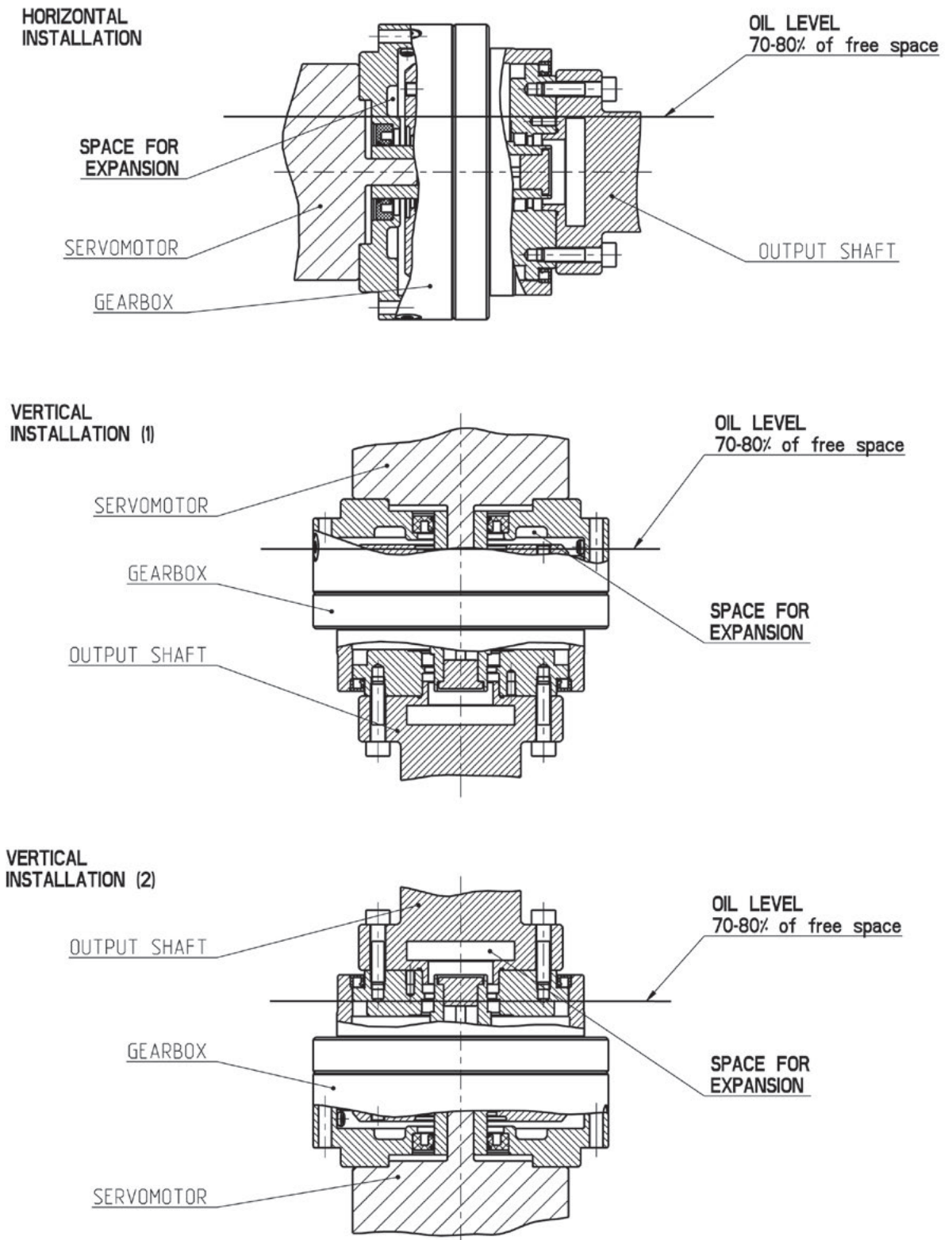


Fig. 5.5a: Lubricant levels in horizontal and vertical positions

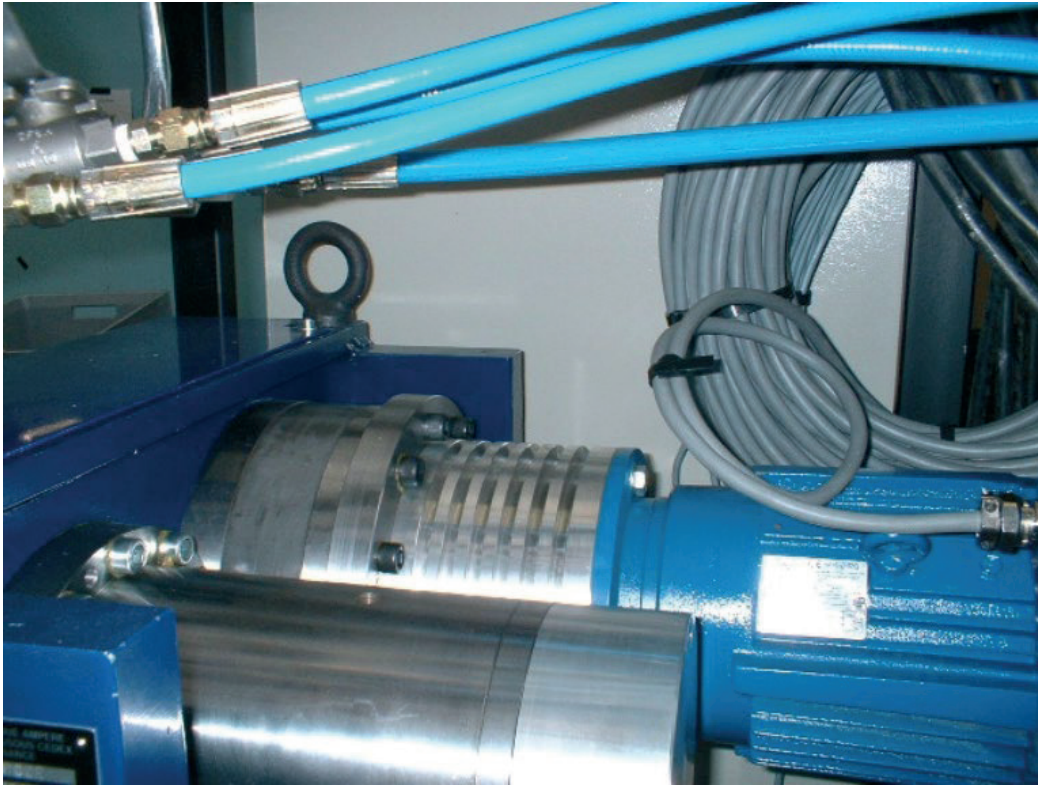


Fig. 5.5b: Example of a reduction gear's cooling

Pre-heating

Pre-heating is only used in very rare cases when the reduction gear is run with a very low duty factor at extreme ambient temperature variations or at very low ambient temperatures.

The reduction gear should normally be pre-heated in temperatures lower than $-10\text{ }^{\circ}\text{C}$. This is not necessary if the temperatures are constant and not so low and the speed values as well as the values of the torque to be transmitted are low, but in any case a special run-in and pre-heating cycle is needed. At such temperatures it is necessary to count with a higher start-up torque and thus with a more generous sizing of the drive motor.

In such cases please contact our sales department for technical support.

5.6 Thermal conditions

The TwinSpin® reduction gears are designed for the ambient temperature range of $-10\text{ }^{\circ}\text{C}$ to $+40\text{ }^{\circ}\text{C}$. Applications for other thermal conditions should be consulted with the sales department or your local sales representative.

5.7 Motor flanges

Most motor adaptor flanges are available on request. Please contact the sales department or your local sales representative for further assistance.



6. General information

6.1 Maintenance

The reduction gear does not require any special maintenance. During its installation please observe the respective dimensional and positional tolerances of the centering diameters (Chapter 5.3). The reduction gear is a high-precision product, therefore it requires careful manipulation, installation, and demounting.

Any tampering with the reduction gear (disassembly, assembly) constitutes immediate loss of warranty. If a reduction gear fails due to a fault in its manufacturing or a material defect, please inform the manufacturer, who will carry out professional repair or replacement.

6.2 Delivery conditions

The reduction gear is delivered completely assembled, without fixing screws, filled with grease, and in a protective package. Not all series are fully sealed as a standard. Each reduction gear is identified with a type label, containing the following data:

- manufacturer
- product type and size
- reduction ratio
- model
- serial number

6.3 Transport and storage

The reduction gears should be transported in closed transport vehicles, in containers secured against movement or overturning. The mode of transport should follow the mutual agreement between the customer and the supplier. In addition, the product must be protected against the elements, aggressive vapours, dust, and mechanical damage. The manufacturer recommends to store TwinSpin® reduction gears in the original transport package.

The standard packaging in the original package ensures corrosion protection for the period of 6 months during storage in closed rooms with the ambient temperature from 5 °C to 25 °C and the relative humidity up to 60 %. After 6 months it is necessary to preserve the reduction gear again.

6.4 Warranty

The warranty is specified in the General Delivery Terms of SPINEA, s.r.o.. For more information visit our website: www.spinea.com

6.5 Final statement

Any design changes, modifications and improvements, aimed at increasing the technological level of the reduction gear, which, however, do not change the main technical parameters, installation and connection dimensions, may be performed by the manufacturer without prior consent from the customer. Any design changes and/or modifications affecting the critical properties and parameters of the reduction gear are subject to an approval procedure.

6.6 Cautions concerning the application of the TwinSpin® high precision reduction gear

If the end user of the product works in the military field or if the product is to be used for the manufacturing of weapons, the product may be subject to trade controls and export regulations. Before the exporting of the product therefore please check the export and trade control terms and conditions and take the required actions.

- If a fault or a malfunction of the product may directly endanger human lives or if the product is used in devices that may damage the human health (nuclear, space, healthcare facilities, various security systems, etc.), regular checks are essential. In such a case please contact our sales agent or our nearest business office.
- Although this product has been manufactured under strict quality control, if it is to be used in machines that, in the event of a malfunction, may seriously endanger human lives or damage equipment, it is essential to adopt appropriate safety measures.
- If this product is to be used in a special environment (clean rooms, food industry, etc.), please contact our sales agent or our nearest business office.

For more information visit our website: www.spinea.com

6.7 FAQ

01. Q: Are reduction ratios between 20-30 possible with the TwinSpin® reduction gear?
 A: Transmission ratios less than 30:1 can be discussed if requested. Ratios that are not offered as standard bear a higher risk of transmission inaccuracies. Consult the technical and delivery conditions with the sales department or our local sales representative.
02. Q: What is the noise level of TwinSpin® during its operation?
 A: TwinSpin® runs extremely smoothly. Reference noise measurements of the reduction gear mounted on a servomotor are available on request.
03. Q: Do you have any information about the temperature increase during the continuous running of TwinSpin® with the rated load?
 A: The reduction gears are preferably intended for duty cycles S3-S8, i.e. the output speed in applications is variable in both directions. The S1 duty cycle has to be consulted with the manufacturer, but it should not exceed the temperature increase of 40°C measured at the ambient temperature of 25°C.
04. Q: Does the input shaft have an axial play for the compensation of the heat growth from the connected servomotor?
 A: There is an axial clearance at the input shaft of the reduction gear that allows heat dilatation. Please pay attention to the adjustment of clearance when interfacing the reduction gear with a servomotor (see [Chapter 5](#)).
05. Q: Why are there grease and oil lubrication options?
 A: Grease is used for the standard applications. Oil is only used for special application requests where there is demand for very low viscous friction, for high-speed applications, for special conditions and users preferences (e.g. extremely cold environment for radar applications).
06. Q: Is it possible to use the TwinSpin® reduction gear independently of the installation position?
 A: The installation position may be vertical or horizontal. The manufacturer provides engineering support, including assembly drawings, on request.
07. Q: What does „nominal lifetime L_{10} ” mean?
 A: The nominal lifetime L_{10} means the time in hours when up to 10% of a batch fails due to material fatigue.
08. Q: Which duty cycle (load) determines the rated torque and the corresponding nominal life?
 A: The rated torque is a calculated value of the loading constant torque at the nominal constant input speed of the input shaft for the duty cycle when the calculated nominal lifetime is $L_{10} = 6.000$ hours and the duty factor $ED = 1$ (100%).
09. Q: Do you provide interface flanges and motor shaft connections for different servomotors?
 A: Yes. We are able to provide you with the necessary technical support. Regarding the flange interfacing, we have a database of typical drawings of connecting couplings and interface flanges. We are able to prepare the assembly and detail drawings for customers, if they exactly specify the type and size of motor. We are also able to manufacture the motor flange and coupling on request.
10. Q: The pair of flanges rotate at a reduced speed with respect to the case. Is there any radial-axial clearance on the output bearing with respect to the reduction gear case?
 A: There are two options. The first one is no clearance and prestressed in both directions as necessary. The second one is the axial and radial clearance of up to 10 microns.
11. Q: Why is TwinSpin® characterized as a zero-backlash reduction gear?
 A: TwinSpin® is a zero backlash reduction gear because there is no reversal clearance between the trochoid teeth of the gear wheels and the cylindrical rollers of the hollow gear wheels in the reduction gear case. This is reached by high-precision manufacturing of components and careful pairing during the assembly.
12. Q: Is TwinSpin® self-locking?
 A: No. Thanks to very good efficiency there is no self-locking effect. For back-driving torque values see [Chapter 3.13](#).
13. Q: Which part of TwinSpin® do you use to calculate the lifetime, i.e. which part of the reduction gear fails first?
 A: The nominal lifetime is limited by the roller bearing between the eccentric shaft and the gearwheels.

Schweiz

Nozag AG

Barzloostrasse 1
CH-8330 Pfäffikon/ZH

Telefon +41 44 805 17 17

Aussendienst Westschweiz
Telefon +41 79 886 76 83

www.nozag.ch
info@nozag.ch