

NSE 5-RN/RL

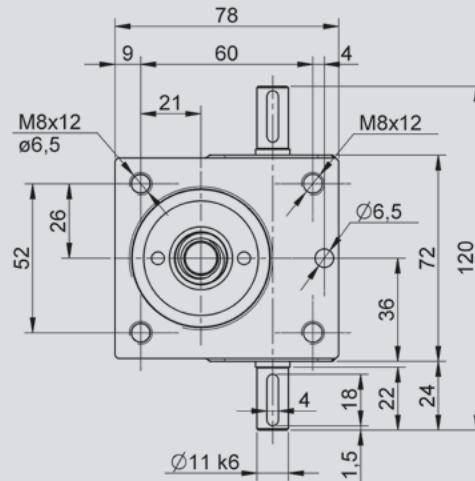
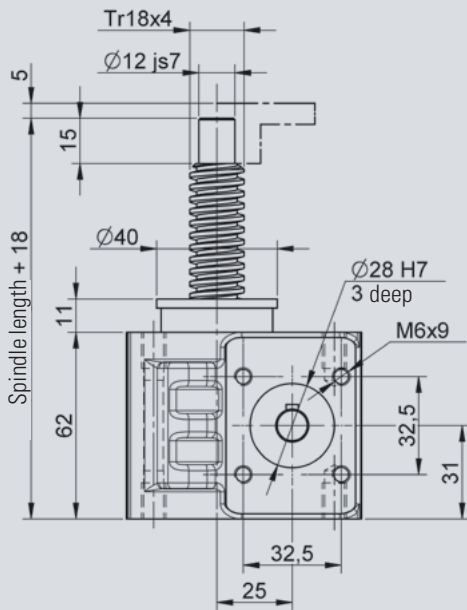
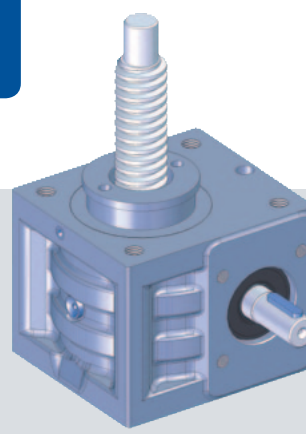

The innovative modular screw jack system from Nozag, allows for perfect drive solutions from low cost standard components. The kit is subject to the highest standards of functionality, quality and design. With little effort, very much can be moved and still, the investment, maintenance and operating costs are kept within narrow limits.

Screw jacks developed and produced by Nozag, solve these tasks in a simple and cost efficient manner.

Specifications

Maximum lifting capacity	5 kN (500 kg)
Maximum driveshaft speed	1400 min ⁻¹ (higher on request)
Spindle	TR 18/4 (standard) TR 24/5 (optional, strengthened version)

Material

Material (housing):	Aluminium
Lubrication:	Grease

Weight

Screw jack weight:	1.02 kg (with grease / without spindle)
Spindle weight:	1.58 kg/m

Features

Type	Ratio	Stroke per revolution	Driving torque ¹	Max torque	Drive through torque ²
	i				
NSE5-RN	4:1	1.00	F(kN) x 0.45 + 0.10	5.60	23
NSE5-RL	16:1	0.25	F(kN) x 0.15 + 0.08	2.00	23
NSE5-RN³	4:1	1.25	F(kN) x 0.58 + 0.10	5.60	23
NSE5-RL³	16:1	0.31	F(kN) x 0.20 + 0.08	2.00	23

1) Factor includes efficiency, ratio and 30% safety

2) By more that six gearboxes in series, please contact our technicians

3) Optional, strengthened version TR24/5

	Basis	Options
Spindle length		
Stroke:	
Safety clearance (spindle pitch)	+ 4	
Basis length	+ 55	
Flange nut (FM)		+ 35
Duplex nut (DMN)		+ 35
Safety nut (SFM)		+ 14
Safety clearance (spindle pitch)	+ 4	
Pin		+ 15

Compressed length of bellows above nut

Compressed length of bellows beneath nut

Overall length of spindle = + =

Compressed length of bellows

$$\text{Stroke} / 10.5 = \dots \times 2,1 = \dots$$

(round number)

Buckling

(Load case-Spindletype)

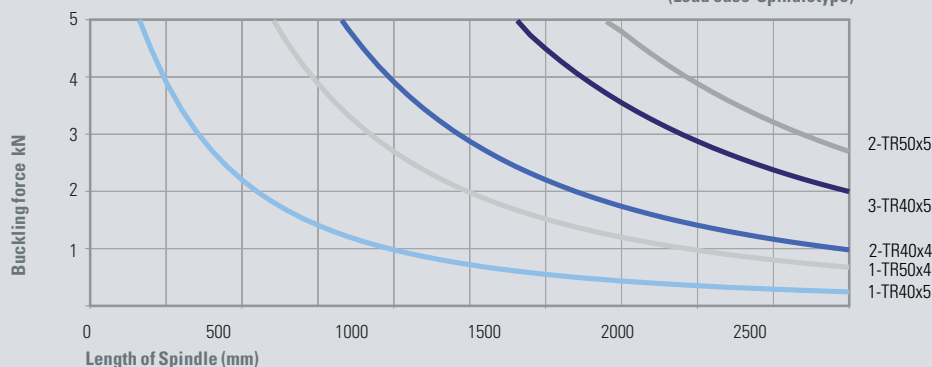

Load case



Determine, in the diagram (calculated with safety 1), with the corresponding load case (1 / 2 / 3), the intersection of the buckling force F and free spindle length L . The intersection point must lie below the boundary line of the chosen spindle diameter. If not, a bigger spindle, respectively, the next larger gearbox is to be selected.

Critical speed

(Load case-Spindletype)

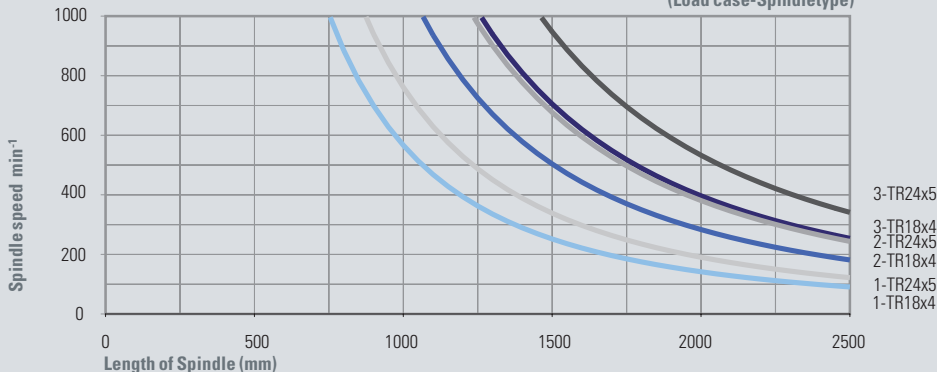

Load case

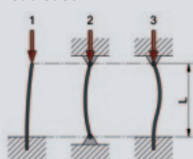

Determine, in the diagram (calculated with safety 1), with the corresponding load case (1 / 2 / 3), the intersection of the buckling force F and free spindle length L . The intersection point must lie below the boundary line of the chosen spindle diameter. If not, a bigger spindle, respectively, the next larger gearbox is to be selected.

We reserve the right on printing and dimension errors, as well as technical changes and improvements.

CAD files can be downloaded at www.nozag.ch.

Attachments



- 1 Spindle
- 2 Flange nut
- 3 Duplex nut
- 4 Calotte disks
- 5 Carrier flange
- 6 Flange bearing
- 7 Suspension adapter for gearboxes
- 8 Suspension adapter for flange nut
- 9 Protection cap
- 10 Bellows
- 11 Spiral spring cover
- 12 Lubricant dispenser
- 13 Hand wheel

Drive components

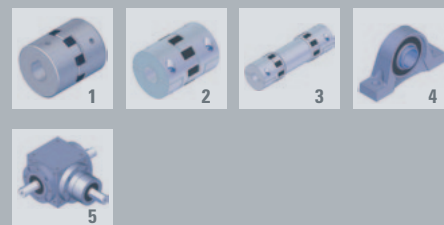

- 1 Coupling
- 2 Clamp coupling
- 3 Connecting shaft
- 4 Pedestal bearing
- 5 Bevel gearboxes

Motor mounting



- 1 Motor adapter
- 2 Motor/brake motor
- 3 Rotary pulse encoder
- 4 Spring brake

Refer to the catalog system program, for attachments, drive components and motor mountings.

Available on request:

- > Double-threaded trapezoidal screw
- > Ballscrew
- > Stainlesssteel spindle (INOX)
- > Surface-treated spindle